

A PROJECT OF THE
PEORIA PARK DISTRICT
PEORIA, ILLINOIS

**FRONT VESTIBULE REPAIR
BRADLEY PARK - EQUIPMENT SERVICE CENTER
1314 N. PARK RD
PEORIA, IL 61604**



PROJECT # 26-008
April 14, 2026

PROJECT MANUAL

PACKAGE # _____

PROJECT MANUAL INCLUDING SPECIFICATIONS FOR:

**FRONT VESTIBULE REPAIR
BRADLEY PARK – EQUIPMENT SERVICE
CENTER 1314 N. PARK RD
PEORIA, IL 61604**

OWNER: PLEASURE DRIVEWAY AND PARK DISTRICT OF PEORIA,
PEORIA, ILLINOIS

TRUSTEES: ROBERT L. JOHNSON, SR., PRESIDENT
MARK SLOVER
STEVE MONTEZ
RON SILVER
JOYCE HARANT
REAGAN LESLIE HILL
ALEX SIERRA

PROJECT MANAGER: DAVID VOORHEES
PLANNING, DESIGN & CONSTRUCTION DIVISION
BRADLEY PARK EQUIPMENT SERVICE
1314 N. PARK ROAD
PEORIA, ILLINOIS 61604
TELEPHONE: (309) 678-0560

ADMINISTRATIVE STAFF: EMILY CAHILL, EXECUTIVE DIRECTOR
MATT FREEMAN, SUPERINTENDENT OF PARKS
KARRIE ROSS, SUPERINTENDENT OF FINANCE
AND ADMINISTRATIVE SERVICES
BECKY FREDRICKSON, SUPERINTENDENT OF PLANNING,
DESIGN AND CONSTRUCTION
SHALESSE PIE, SUPERINTENDENT OF HUMAN
RESOURCES
SCOTT LOFTUS, SUPERINTENDENT OF RECREATION

Address all communications regarding this work to the Project Manager listed above.

ADVERTISEMENT FOR BIDS

Sealed bids will be received by the Peoria Park District, Peoria, Illinois, hereinafter known as the Owner, for the following project:

FRONT VESTIBULE REPAIR
BRADLEY PARK
EQUIPMENT SERVICE CENTER
1314 N PARK RD
PEORIA, IL 61604

It is the intent of the Owner to receive Base Bids for the project listed above.

Sealed bids will be received until TUESDAY, April 28, 2026 at 1:00 pm prevailing time, by the Owner, at the Peoria Park District Administrative Office, 1125 W. Lake Ave., Peoria, Illinois 61614. (The Board Room clock shall be the official time keeping device in respect to the bid submission deadline.)

An electronic file including Bid Documents is available at www.peoriaparks-planning.org at no charge. Bid Documents, including Plans, Specifications and Interpretations for this project may be obtained at the Planning, Design & Construction Department, Bradley Park Equipment Service, 1314 N. Park Road, Peoria, IL 61604. Telephone (309) 686-3386. A non-refundable plan deposit of THREE HUNDRED DOLLARS (\$300.00) will be charged for each printed set of Bid Documents.

A list of planholders can be obtained upon request. This information will be available up to twenty-four (24) hours prior to the scheduled bid opening time. **After that deadline, no information pertaining to the project will be given.**

A 10% Bid Bond is required, and is to be included with the Bid Proposal. The successful Bidder will be required to furnish a 100% Performance Bond and a 100% Labor and Materials Payment Bond within ten (10) days of formal Award of Contract.

The general prevailing rate of wage for the Peoria area shall be paid for each craft or type of worker needed to execute this contract or perform this work as required by the State of Illinois Department of Labor. Additionally, it is required that provisions of the Illinois Preference Act, the Illinois Drug Free Workplace Act, and the Substance Abuse Prevention on Public Works Act must be adhered to. Bidders are also advised that contract documents for this project include the non-discrimination, equal opportunity and affirmative action provisions in the Human Rights Act and rules and regulations of the Department of Human Rights. The Peoria Park District is an AA/EEO organization and encourages participation by minority and female-owned firms.

The Peoria Park District reserves the right to reject any or all bids, waive technical deficiencies, informalities or irregularities or rebid any project.

PLEASURE DRIVEWAY AND PARK DISTRICT
OF PEORIA, ILLINOIS

BY: ROBERT L. JOHNSON, SR., President

BY: ALICIA WOODWORTH, Secretary

TABLE OF CONTENTS

TITLE PAGE(S)	1-2
INVITATION TO BID	3
TABLE OF CONTENTS	4
BIDDING DOCUMENTS:	
- SUPPLEMENTARY INSTRUCTIONS TO BIDDERS	6-9
- BID FORM(S)	11-13
- SUBCONTRACTORS LIST	14
- CERTIFICATION OF COMPLIANCE OF LISTED PROVISIONS AND LAWS	15
- W-9	16-21
- SEXUAL HARASSMENT POLICY STATEMENT	22
- SAMPLE ADDENDUM FORM	23
CONTRACT DOCUMENTS:	
- AGREEMENT BETWEEN OWNER AND CONTRACTOR	24-27
- PERFORMANCE BOND	29-30
- LABOR & MATERIALS PAYMENT BOND	31-32
- CONTRACTOR'S AFFIDAVIT	33
- LIEN WAIVER FORMS	34-37
- SUPPLEMENTAL GENERAL CONDITIONS	38-54
PROJECT SPECIFICATIONS:	
GENERAL REQUIREMENTS:	
<u>DIVISION 010000: GENERAL REQUIREMENTS</u>	55-66
TECHNICAL SPECIFICATIONS:	
DIVISION 01 - GENERAL REQUIREMENTS	
011000	SUMMARY
DIVISION 02 - EXISTING CONDITION	
024119	SELECTIVE DEMOLITION
DIVISION 06 - WOOD, PLASTICS & COMPOSITES	
061300	HEAVY TIMBER CONSTRUCTION
DIVISION 07 - THERMAL AND MOISTURE PROTECTION	
079200	JOINT SEALANTS
DIVISION 09 - FINISHES	
099123	EXTERIOR PAINTINGS
099300	STAINING AND TRANSPARENT FINISHING
EXHIBITS:	
ATTACHMENT A - INSURANCE REQUIREMENTS	5 PAGES
ATTACHMENT B – SOLICITATION & HIRING FOR QUALIFYING CONSTRUCTION CONTRACTS POLICY & FORMS	21 PAGES
ATTACHMENT C – DIRECTORY OF MINORITY & WOMEN OWNED BUSINESS ENTERPRISES	5 PAGES
ATTACHMENT D – PREVAILING WAGES FOR PEORIA COUNTY – ILLINOIS DEPARTMENT OF LABOR	6 PAGES

DRAWINGS:

G1	TITLE SHEET
A1	EXISTING / REVISED PLANS & ELEVATION
A2	EXISTING ELEVATION PICS & NOTES
A3	EXISTING INTERIOR ELEVATION PICS & NOTES
A4	EXTERIOR ELEVATION / BUILDING SECTIONS
A5	BUILDING SECTION / FRAMING DETAILS

END OF TABLE OF CONTENTS

SUPPLEMENTARY INSTRUCTIONS TO BIDDERS

1. INSTRUCTIONS TO BIDDERS

- A. "Instructions to Bidders", AIA Document A701, 2018 Editions, published by the American Institute of Architects, including revisions adopted before date of this Project Manual, is hereby made part of these specifications with same force and effect as though set forth in full.
- B. The following modifies, changes, deletes from or adds to the **Instructions to Bidders** (AIA Document A701, 2018 Edition). Where any Article of the Instructions to Bidders is modified or any Paragraph, Subparagraph or Clause thereof is modified or deleted by these Supplementary Conditions, the unaltered provisions of that Article, Paragraph, Subparagraph or Clause shall remain in effect.
- C. Parenthesis () indicates the appropriate section and Subparagraph of the Instructions to Bidders which each paragraph of the Supplementary Instructions to Bidders modifies or refers to.

2. PROJECT DESCRIPTION

- A. The Project description generally is as follows:
BASE BID:
Project Consists of Vestibule glass removal and reinstallation, rough carpentry removal and full replacement with matching Lumber type, sealants, minor painting, rough carpentry removal and miscellaneous repairs.
- B. **PRE-BID MEETING :**
A pre-bid meeting will be held on April 22, 2026, at 9:30 AM, in the parking lot of Equipment Service Center located in Laura Bradley Park.

3. CODES AND PERMITS

- A. **COSTS ASSOCIATED WITH REGULATORY COMPLIANCE.** All Work performed in connection with this Project shall be in compliance with the requirements of all applicable local, state, and federal laws, regulations, and rules, as well as the requirements of the Construction Documents. The Bid Price shall reflect all costs of compliance to those requirements, whether or not specifically stated in the Construction Documents or specific sections of the Project Manual.
- B. **PERMITS/FEES.** Work shall not commence until all required building (and/or other) permits have been secured by the Contractor and copies of these permits submitted to the Owner's Representative. Cost of permits is to be included in the Bid Price.

4. BID GUARANTY

The bid must be accompanied by a Bid Guaranty which shall not be less than 10% of the amount of the Bid. At the option of the Bidder, the 10% Guaranty may be a Certified Check, Cashier's Check, or a Bid Bond. The Bid Bond shall be secured by a Guaranty or a Surety Company acceptable to the Owner. No bid will be considered unless it is accompanied by the required Guaranty. Funds must be made payable to the order of the Owner. Cash deposits will not be accepted. The Bid Guaranty shall ensure the execution of the Agreement and the furnishing of the Surety Bond or Bonds by the successful Bidder, all as required by the Contract Documents.

5. AWARD OF CONTRACT/REJECTION OF BIDS:

The Contracts will be awarded on the basis of Paragraph 5.3 of the Instructions to Bidders and Paragraph 16 of the Supplementary Instructions to Bidders. The Bidders to whom the awards are made will be notified at the earliest possible date. The Owner, however, reserves the right to reject any and all Bids, to accept any combination of base bids and alternates and to waive any technical deficiencies, informalities, or irregularities in Bids received whenever such rejection or waiver is in its interest.

No bid shall be withdrawn for a period of sixty (60) days after the opening of bids without the consent of the Owner. The failure of the Bidder to submit a Bid Bond, Certified Check or Cashier's Check in the full amount to cover all proposals bid upon shall be sufficient cause for rejection of his bid. The award will be made contingent upon submittal and evaluation of Contractor's Qualification Statement if requested, Bonds, Certificate of Insurance, Contractor Certifications, including Certification of Compliance of Listed Provisions and Laws, Peoria Park District Certificate of Equal Employment Opportunity Compliance for Contractors and Vendors, Workforce Profile, Company Ownership Certification, Minority/Women Owned Contact Sheet, Contractor/Subcontractor Workforce Plan, etc.

6. EXECUTION OF AGREEMENT:

Following the award and within ten (10) days after the prescribed forms are prepared and presented for signature by the Owner's Representative, the successful Bidder shall execute and return to the Owner's Representative the Agreement in the form included in the Contract Documents in such number of copies as the Owner may require. The Owner's Representative will provide Notice to Proceed after all bonds and any other required documents have been received by the Park District.

7. PERFORMANCE BOND/LABOR AND MATERIAL PAYMENT BOND & INSURANCE

- A. **BONDS REQUIRED.** Having satisfied all conditions of award as set forth elsewhere in these Documents, the successful Bidder shall, within ten (10) calendar days after award of contract, furnish Surety Bonds in penal sums, each not less than the amount of the Contract as awarded as security for the faithful performance of the Contract (Performance Bond), and for the payment (Labor and Materials Payment Bond) of all persons, firms or corporations to whom the Contractor may become legally indebted for labor, materials, tools, equipment or services employed or used by him in performing the work.

- B. FORM OF BONDS.** Such bonds shall be in the same form as the samples included in the Project Manual and shall bear the same date as or a date subsequent to that of the Agreement. The current Power of Attorney for the person who signs for any Surety Company shall be attached to such Bonds. Bonds shall be signed by a Guaranty or Surety Company acceptable to the Owner.
- C. COST OF PERFORMANCE BOND/LABOR AND MATERIAL PAYMENT BOND.** All costs for the Performance Bond/Labor and Material Payment Bond shall be included in the submitted Bid Price.
- D. INSURANCE.** Insurance requirements for this project are addressed both in the Supplementary General Conditions and in "Attachment A.6", in the "Exhibits" section of this Project Manual.
 - a) In respect to the property ("builders risk") insurance coverages referenced in the Supplementary General Conditions: the successful Bidder will be required to provide such coverages as the work of the Project will be accomplished by one general/prime contractor(s).
- E. TIME FRAMES.** The successful Bidder shall, within ten (10) days after award of contract by the Board of Trustees, submit Proof of Insurance coverages/Bonds in the form and amounts required to the Owner's Representative. Should the Bidder be unable to provide the required Proof of Insurance(s)/Bonds within the specified ten-day period the Owner reserves the right, at its sole discretion, to withdraw its award of contract from that Bidder.

8. DEFAULT

- A. The failure of the successful Bidders to execute the Agreement, supply the required Bonds or proof of required insurance coverage(s) within (ten) 10 days after award of contract, or within such extended period as the Owner may grant based upon reasons determined sufficient by the Owner, may constitute a default. In such case, award of contract will be transferred to the second lowest bidder.

9. CONTRACTOR'S QUALIFICATION STATEMENT

- A. Contractor's Qualification Statement (AIA Document 305) shall be submitted by low bidder for evaluation prior to award of contract if so, requested by the Owner or his representatives.

10. LIST OF SUBCONTRACTORS/PRODUCT & EQUIPMENT SUBSTITUTIONS

- A. Each Bidder shall submit a "SUBCONTRACTORS LIST" proposed to be used in the execution of the Work. If there will be no subcontractors, the Bidder shall state "No Subcontractors" on this form. The completed form is due with the Bid Proposal.
 - 1) Identify the trade name, address, telephone number, and category of work of each subcontractor.
 - 2) Failure to submit the "Subcontractors List" with the Bid Proposal may result in the rejection of the Bid.
 - 3) Delete Subparagraphs (6.3.1.1) from AIA A701.
- B. The Bidder, by submission of a signed bid form, agrees to install all products and equipment by brand name or names specified in the Technical Specifications sections of this Project Manual. "Or equal" substitutions will be allowed only if approved in writing prior to the bid opening and listed in the "Substitutions" section of the Bid Form.

11. CONTRACT ADMINISTRATION FORMS/COSTS OF FORMS

- A. **REQUIRED FORMS.** The following AIA forms will be used (AIA forms will be supplied by the Owner if requested, and charged to the Contractor at cost) in the administration of the project:
 - 1) **AIA Document A310:** "Bid Bond", February 1970 edition
 - 2) **AIA Document A305:** "Contractor's Qualification Statement", 1986 edition
 - 3) **AIA Document G702:** "Application and Certificate of Payment", May 1992 edition
 - 4) **AIA Document G703:** "Continuation Sheet", May 1992 edition
- B. **OTHER FORMS.** Other contract administration forms (to be provided by the Owner unless otherwise noted) required for use in the Project are:
 - 1) **Subcontractors List**
 - 2) **Contractor's Affidavit**
 - 3) **Performance Bond**
 - 4) **Labor and Material Payment Bond**
 - 5) **Lien Waiver Forms**
 - 6) **Certified Payroll Form**

Please Note: Illinois State Law has changed. As a Contractor on a public works project, Contractor must submit certified payroll directly to the Illinois Department of Labor. See details at <https://www2.illinois.gov/idol/laws-rules/conmed/pages/prevailing-wage-portal.aspx>

The first time submitting certified payroll to this site requires additional set-up time and specialized forms that must
Project Manual - Front Vestibule Repair Bradley Park Equipment Service Center

be used.

After submitting certified payroll directly to the Illinois Department of Labor, Contractor will receive a PDF proof of submittal. A copy of this PDF proof of submittal is required with pay applications to Owner.

- 7) **Insurance Forms: As required in Attachment A (at end of Project Manual)** (will not be provided by Owner)
- 8) **Agreement Between Owner and Contractor**

12. CONSTRUCTION TIME AND LIQUIDATED DAMAGES CLAUSE:

PROJECT COMPLETION. The Agreement will include the following paragraph(s) or language substantially the same, regarding construction time and liquidated damages:

- 1) **LIQUIDATED DAMAGES:** Owner and Contractor recognize that time is of the essence of this Agreement and that Owner will suffer financial loss if the Work is not Substantially Complete within the time specified below, plus any extensions thereof allowed in accordance with Article 8 of the General Conditions. They also recognize the delays, expense and difficulties involved in proving in a legal or arbitration proceeding the actual loss suffered by Owner if the Work is not completed on time.
- 2) Accordingly, instead of requiring any such proof, Owner and Contractor agree that as Liquidated Damages for delay (but not as a penalty) Contractor shall pay Owner TWO HUNDRED AND FIFTY DOLLARS (\$250.00) for each calendar day that expires after calendar days from Notice of Award until Substantial Completion is attained. The work is tentatively scheduled to begin on May 14, 2026 and be at Substantial Completion by September 30, 2026.
- 3) After Substantial Completion, if Contractor shall neglect, refuse, or fail to complete the remaining Work necessary to achieve Final Completion within One hundred and forty days (140) calendar days or any proper extension thereof granted by Owner, Contractor shall pay Owner TWO HUNDRED AND FIFTY DOLLARS (\$ 250.00) dollars for each day that expires after the time specified.
- 4) Owner and Contractor agree that the per day liquidated damage amounts set forth in subparagraphs "2" and "3" of this section constitute a reasonable forecast of the financial losses, actual costs and increased expenses the Owner may incur as a result of delayed Substantial or Final Completion of the Project.

13. PROJECT MANUAL/PLANS & SITE VISITATION

- A. A set of Bid Documents may be examined, at no charge, at the office of the Owner's Representative.
- B. **PLAN DEPOSIT.** An electronic file including Bid Documents is available at www.peoriaparks-planning.org at no charge. A printed set of Bid Documents, including Plans, Specifications and Interpretations for this project may be obtained at the Planning, Design & Construction Department, Bradley Park Equipment Service, 1314 N. Park Road, Peoria, IL 61604. Telephone (309)686-3386. A non-refundable plan deposit of Three Hundred dollars (\$300.00) will be charged for each printed set of Bid Documents.
- C. **FAMILIARITY WITH BID DOCUMENTS & SITE VISITATION.** Bidders, by submission of their Bids, represent that they have visited the site to acquaint themselves with the local conditions in which the Work is to occur, and that they are familiar with all the requirements of the Project, as defined in the Project Manual and the Plan(s).

14. OTHER MODIFICATIONS TO AIA-701/OTHER CONDITIONS

- A. Add the following sentence to (4.1.7): "Bidder shall submit two (2) completed copies of Bid Form and retain one (1) copy for his files."
- B. Delete (4.2.1)
- C. Delete Section (6.2) - "Owner's Financial Capability"
- D. In reference to (7.2.1), the Peoria Park District reserves the right of final approval of bonding companies. Replace the first Sentence with "The Bidder shall deliver the required bonds to the Owner not later than ten days following the date of execution of the Contract."
- E. Delete paragraph (7.1.3).

15. EQUAL EMPLOYMENT OPPORTUNITY/SEXUAL HARASSMENT

- A. It is a goal of the Peoria Park District to encourage participation of minorities and women on Peoria Park District construction projects through contracts and workforce. Good Faith Effort must be made to encourage the use of minority and women owned businesses as sub-contractors and suppliers on the project.

On all bids \$50,000.00 and over, see requirements listed in **Attachment B "Solicitation and Hiring for Qualifying Construction Contracts & Forms"**.

On all bids less than \$50,000.00, complete and submit the following listed forms (provided in Attachment B) with the Bid. Failure to submit the forms may result in rejection of the bid.

1. "Peoria Park District Certificate of Equal Employment Opportunity Compliance for Contractors and Vendors" Form
2. "Workforce Profile" Form
3. "Company Ownership Certification" Form

B. Effective July 1, 1993, every party to a public contract and every party bidding on public contracts is required to have a written "**Sexual Harassment Policy**". The Sexual Harassment Policy must contain:

- 1) A definition of sexual harassment under state law;
- 2) A description of sexual harassment utilizing examples;
- 3) A formalized complaint procedure;
- 4) A statement of victim's rights;
- 5) Directions on how to contact the Illinois Department of Human Rights - **Illinois companies**. Out-of-State companies must include directions on how to contact the enforcement agency within their state. Companies that issue a standard policy for all business locations must prepare an addendum providing directions on how to contact the appropriate enforcement agency.
- 6) A recitation that there cannot be any retaliation against employees who elect to file charges.

Recommendation: Your "**Sexual Harassment Policy**" should be drafted in language easy to understand and any revisions should be reviewed by legal counsel. A copy of your policy should be posted in a prominent and accessible location to assure all employees will be notified of the company's position.

In order to conduct business with the Peoria Park District, you must have a written "Sexual Harassment Policy" that conforms to the Act.

FAILURE TO DO SO WILL DISQUALIFY YOU AS AN ELIGIBLE VENDOR.

16. BID SUBMISSION

A. DATE, TIME & PLACE OF RECEIVING BIDS. Bids will be received until the date and time listed in the "Advertisement for Bids", at which time they will be publicly opened, read aloud and recorded. The Bid Opening will be held at the place listed in the "Advertisement for Bids".

B. REQUIRED ITEMS. The following items must be included as part of the "BID":

- 1) Two (2) signed copies of the **BID FORM**. (Retain the third copy for your files.)
- 2) The **SUBCONTRACTORS LIST**. (Submit form and state "No Subcontractors" on the form, if none will be used.)
- 3) The **PEORIA PARK DISTRICT CERTIFICATE OF EQUAL EMPLOYMENT OPPORTUNITY COMPLIANCE FOR CONTRACTORS AND VENDORS** form.
- 4) The **WORKFORCE PROFILE** form.
- 5) The **COMPANY OWNERSHIP CERTIFICATION** form.
- 6) The **CERTIFICATION OF COMPLIANCE OF THE LISTED PROVISIONS AND LAWS** form.
- 7) Completed **W-9**.
- 8) The **BID GUARANTY**.
- 9) If the bid is over \$50,000.00, the **MINORITY/WOMEN OWNED CONTACT SHEET** form.
- 10) If the bid is over \$50,000.00, the **CONTRACTOR/SUBCONTRACTOR WORKFORCE PLAN** form.

C. BID SUBMISSION. The "BID" shall be enclosed in envelopes (outer and inner), both of which shall be sealed and clearly labeled with the following information, in order to prevent premature opening of the bid:

- "PROPOSAL"
- NAME OF PROJECT
- NAME OF BIDDER
- DATE/TIME OF BID OPENING

END OF SUPPLEMENTARY INSTRUCTIONS TO BIDDERS

Bid From: _____

PROJECT NO. 26-008
BID FOR: Front Vestibule Repair
LOCATION: Bradley Park Equipment Service Center

BID FORM

BID TO: PEORIA PARK DISTRICT

UNDERSIGNED:

1. Acknowledges receipt of:
 - A. Project Manual and Drawings for:

 - B. Addenda: No. _____ through No. _____
2. Has examined facility and the bid documents and shall be responsible for performing work specifically required of him by all parts of bidding documents including specifications for entire project, even though such work may be included as related requirements specified in other divisions or sections.
3. And agrees to enter into and execute Contract with Owner, if awarded on basis of this bid, and to:
 - A. Furnish Bonds and Insurance required by the Bidding & Contract Documents.
 - B. Accomplish work in accord with Contract.
 - C. Complete work within specified Contract time.
4. **CONTRACT TIME:** Contractor agrees to Substantially Complete ALL WORK as required by the Contract Documents per the Supplementary General Conditions and Supplementary Instructions to Bidders.
5. **BASE BIDS:**
 - A. Base Bid:
Bidder agrees to perform all building and site work, as set forth in the Project Manual and Drawings for the sum of:

_____ Dollars (\$_____.____)

Bid From: _____

PROJECT NO. 26-008
BID FOR: Front Vestibule Repair
LOCATION: Bradley Park Equipment Service Center

6. **PROPOSED SUBSTITUTION LIST:**

Base Bid(s) and Alternates are understood to include only those product brands, items, and elements which are specified in the Bid Documents. The following is a list of substitute products, equipment or methods of construction which the Bidder proposes to furnish on this project, with difference in price being added or deducted from Base Bid(s).

Bidder understands that acceptance of any proposed substitution which has not been approved as an "equal" to the product brand, item, or element specified prior to bid opening is at Owner's option. Approval or rejection of any substitutions listed below will be indicated before executing Contract.

<u>ITEM</u>	<u>ADD</u>	<u>DEDUCT</u>
_____	\$ _____	\$ _____
_____	\$ _____	\$ _____
_____	\$ _____	\$ _____

7. **BIDDERS CHECKLIST:**

Did you visit the site?	Yes	No
Is Bid Security enclosed? (If applicable)	Yes	No
Is Peoria Park District Certificate of Equal Employment Opportunity Compliance for Contractors enclosed?	Yes	No
Is Workforce Profile enclosed?	Yes	No
Is Company Ownership Certification enclosed?	Yes	No
If the bid is \$50,000.00 or over, the Minority/Women Owned Contact Sheet enclosed?	Yes	No
If the bid is \$50,000.00 or over, the Contractor/Subcontractor Workforce Plan enclosed?	Yes	No
Is Subcontractors List enclosed?	Yes	No
Is Certification of Compliance of the Listed Provisions and Laws form enclosed?	Yes	No
Is a completed W-9 enclosed?	Yes	No

8. **BIDDER INFORMATION:**

NAME OF BIDDER: _____

ADDRESS: _____

Bid From: _____

PROJECT NO. 26-008
BID FOR: Front Vestibule Repair
LOCATION: Bradley Park Equipment Service Center

CITY, STATE, ZIP: _____

TELEPHONE NO.: _____

BY: _____
(Signature of Authorized Official)

TITLE: _____

BIDDER'S SEAL

WITNESS: _____

END OF BID FORM

SUBCONTRACTORS LIST

The following tabulation of Subcontractors shall be attached and made a condition of the Bid. The Bidder expressly understands and agrees to the following provisions:

- A. If awarded a Contract as a result of this Bid, the subcontractors used in the prosecution of the work will be those listed below.
- B. The following list includes all subcontractors, known at the time of the Bid, who will perform work on this project.
- C. The subcontractors listed below are financially responsible and are qualified to perform the work required.
- D. The subcontractors listed below comply with the requirements of the Contract Documents.
- E. Any substitutions in the subcontractors listed below shall be requested in writing by the Contractor and must be approved in writing by the Owner. No sub-subcontractors will be allowed unless specifically stated on the form. All pertinent financial, performance, insurance and other applicable information shall be submitted with the request for substitution(s). Owner shall respond to such requests within 14 calendar days following the submission of all necessary information to the full satisfaction of the Owner.
- F. Failure to submit the list of Subcontractors as stated herein shall constitute a material variation from the Invitation to Bid; and any such Bid may be rejected by the Owner.

Subcontractor Name	Telephone/Email	Area of Work	Minority/Women Owned Business (Yes/No)	Dollar Amount of Contract

BIDDER: _____

END OF SUBCONTRACTORS LIST

**CERTIFICATION OF COMPLIANCE
OF THE LISTED PROVISIONS AND LAWS**

1) Illinois Drug Free Workplace Act of 1991

2) The Substance Abuse Prevention on Public Works Act Public Act 95-0635:

Prohibits the use of drugs and alcohol while performing work on a public works project.

The Contractor/Subcontractor has signed collective bargaining agreement for all of its employees that deal with the subject matter or the Contractor/Subcontractor has a prevention program that meets or exceeds the requirements of the Public Act for all employees not covered by a collective bargaining agreement.

3) Safety Compliance:

Contractor/Subcontractors will comply with any and all prevailing occupational safety and health standards. Such compliance may include a training component or require a written program of compliance.

4) Illinois Criminal Code, Illinois Compiled Statutes 720 ILCS 5/33E-3 and 5/33E-4:

Contractor/Subcontractor has not been barred from bidding on public contract as a result of bid rigging or bid rotating.

The undersigned representative of the Contractor/Vendor hereby certifies to comply with the laws and provisions listed above.

Contractor/Subcontractor

Name of Authorized Representative (type or print)

Signature of Authorized Representative

Date

must obtain your correct taxpayer identification number (TIN), which may be your social security number (SSN), individual taxpayer identification number (ITIN), adoption taxpayer identification number (ATIN), or employer identification number (EIN), to report on an information return the amount paid to you, or other amount reportable on an information return. Examples of information returns include, but are not limited to, the following.

- Form 1099-INT (interest earned or paid).
- Form 1099-DIV (dividends, including those from stocks or mutual funds).
- Form 1099-MISC (various types of income, prizes, awards, or gross proceeds).
- Form 1099-NEC (nonemployee compensation).
- Form 1099-B (stock or mutual fund sales and certain other transactions by brokers).
- Form 1099-S (proceeds from real estate transactions).
- Form 1099-K (merchant card and third-party network transactions).
- Form 1098 (home mortgage interest), 1098-E (student loan interest), and 1098-T (tuition).
- Form 1099-C (canceled debt).
- Form 1099-A (acquisition or abandonment of secured property).

Use Form W-9 only if you are a U.S. person (including a resident alien), to provide your correct TIN.

Caution: If you don't return Form W-9 to the requester with a TIN, you might be subject to backup withholding. See *What is backup withholding*, later.

By signing the filled-out form, you:

1. Certify that the TIN you are giving is correct (or you are waiting for a number to be issued);
2. Certify that you are not subject to backup withholding; or
3. Claim exemption from backup withholding if you are a U.S. exempt payee; and
4. Certify to your non-foreign status for purposes of withholding under chapter 3 or 4 of the Code (if applicable); and
5. Certify that FATCA code(s) entered on this form (if any) indicating that you are exempt from the FATCA reporting is correct. See *What Is FATCA Reporting*, later, for further information.

Note: If you are a U.S. person and a requester gives you a form other than Form W-9 to request your TIN, you must use the requester's form if it is substantially similar to this Form W-9.

Definition of a U.S. person. For federal tax purposes, you are considered a U.S. person if you are:

- An individual who is a U.S. citizen or U.S. resident alien;
- A partnership, corporation, company, or association created or organized in the United States or under the laws of the United States;
- An estate (other than a foreign estate); or
- A domestic trust (as defined in Regulations section 301.7701-7).

Establishing U.S. status for purposes of chapter 3 and chapter 4 withholding. Payments made to foreign persons, including certain distributions, allocations of income, or transfers of sales proceeds, may be subject to withholding under chapter 3 or chapter 4 of the Code (sections 1441–1474). Under those rules, if a Form W-9 or other certification of non-foreign status has not been received, a withholding agent, transferee, or partnership (payor) generally applies presumption rules that may require the payor to withhold applicable tax from the recipient, owner, transferor, or partner (payee). See Pub. 515, *Withholding of Tax on Nonresident Aliens and Foreign Entities*.

The following persons must provide Form W-9 to the payor for purposes of establishing its non-foreign status.

- In the case of a disregarded entity with a U.S. owner, the U.S. owner of the disregarded entity and not the disregarded entity.
- In the case of a grantor trust with a U.S. grantor or other U.S. owner, generally, the U.S. grantor or other U.S. owner of the grantor trust and not the grantor trust.
- In the case of a U.S. trust (other than a grantor trust), the U.S. trust and not the beneficiaries of the trust.

See Pub. 515 for more information on providing a Form W-9 or a certification of non-foreign status to avoid withholding.

Foreign person. If you are a foreign person or the U.S. branch of a foreign bank that has elected to be treated as a U.S. person (under Regulations section 1.1441-1(b)(2)(iv) or other applicable section for chapter 3 or 4 purposes), do not use Form W-9. Instead, use the appropriate Form W-8 or Form 8233 (see Pub. 515). If you are a qualified foreign pension fund under Regulations section 1.897(l)-1(d), or a partnership that is wholly owned by qualified foreign pension funds, that is treated as a non-foreign person for purposes of section 1445 withholding, do not use Form W-9. Instead, use Form W-8EXP (or other certification of non-foreign status).

Nonresident alien who becomes a resident alien. Generally, only a nonresident alien individual may use the terms of a tax treaty to reduce or eliminate U.S. tax on certain types of income. However, most tax treaties contain a provision known as a saving clause. Exceptions specified in the saving clause may permit an exemption from tax to continue for certain types of income even after the payee has otherwise become a U.S. resident alien for tax purposes.

If you are a U.S. resident alien who is relying on an exception contained in the saving clause of a tax treaty to claim an exemption from U.S. tax on certain types of income, you must attach a statement to Form W-9 that specifies the following five items.

1. The treaty country. Generally, this must be the same treaty under which you claimed exemption from tax as a nonresident alien.
2. The treaty article addressing the income.
3. The article number (or location) in the tax treaty that contains the saving clause and its exceptions.
4. The type and amount of income that qualifies for the exemption from tax.
5. Sufficient facts to justify the exemption from tax under the terms of the treaty article.

Example. Article 20 of the U.S.-China income tax treaty allows an exemption from tax for scholarship income received by a Chinese student temporarily present in the United States. Under U.S. law, this student will become a resident alien for tax purposes if their stay in the United States exceeds 5 calendar years. However, paragraph 2 of the first Protocol to the U.S.-China treaty (dated April 30, 1984) allows the provisions of Article 20 to continue to apply even after the Chinese student becomes a resident alien of the United States. A Chinese student who qualifies for this exception (under paragraph 2 of the first Protocol) and is relying on this exception to claim an exemption from tax on their scholarship or fellowship income would attach to Form W-9 a statement that includes the information described above to support that exemption.

If you are a nonresident alien or a foreign entity, give the requester the appropriate completed Form W-8 or Form 8233.

Backup Withholding

What is backup withholding? Persons making certain payments to you must under certain conditions withhold and pay to the IRS 24% of such payments. This is called "backup withholding." Payments that may be subject to backup withholding include, but are not limited to, interest, tax-exempt interest, dividends, broker and barter exchange transactions, rents, royalties, nonemployee pay, payments made in settlement of payment card and third-party network transactions, and certain payments from fishing boat operators. Real estate transactions are not subject to backup withholding.

You will not be subject to backup withholding on payments you receive if you give the requester your correct TIN, make the proper certifications, and report all your taxable interest and dividends on your tax return.

Payments you receive will be subject to backup withholding if:

1. You do not furnish your TIN to the requester;
2. You do not certify your TIN when required (see the instructions for Part II for details);
3. The IRS tells the requester that you furnished an incorrect TIN;
4. The IRS tells you that you are subject to backup withholding because you did not report all your interest and dividends on your tax return (for reportable interest and dividends only); or
5. You do not certify to the requester that you are not subject to backup withholding, as described in item 4 under "*By signing the filled-out form*" above (for reportable interest and dividend accounts opened after 1983 only).

Certain payees and payments are exempt from backup withholding. See *Exempt payee code*, later, and the separate Instructions for the Requester of Form W-9 for more information.

See also *Establishing U.S. status for purposes of chapter 3 and chapter 4 withholding*, earlier.

What Is FATCA Reporting?

The Foreign Account Tax Compliance Act (FATCA) requires a participating foreign financial institution to report all U.S. account holders that are specified U.S. persons. Certain payees are exempt from FATCA reporting. See *Exemption from FATCA reporting code*, later, and the Instructions for the Requester of Form W-9 for more information.

Updating Your Information

You must provide updated information to any person to whom you claimed to be an exempt payee if you are no longer an exempt payee and anticipate receiving reportable payments in the future from this person. For example, you may need to provide updated information if you are a C corporation that elects to be an S corporation, or if you are no longer tax exempt. In addition, you must furnish a new Form W-9 if the name or TIN changes for the account, for example, if the grantor of a grantor trust dies.

Penalties

Failure to furnish TIN. If you fail to furnish your correct TIN to a requester, you are subject to a penalty of \$50 for each such failure unless your failure is due to reasonable cause and not to willful neglect.

Civil penalty for false information with respect to withholding. If you make a false statement with no reasonable basis that results in no backup withholding, you are subject to a \$500 penalty.

Criminal penalty for falsifying information. Willfully falsifying certifications or affirmations may subject you to criminal penalties including fines and/or imprisonment.

Misuse of TINs. If the requester discloses or uses TINs in violation of federal law, the requester may be subject to civil and criminal penalties.

Specific Instructions

Line 1

You must enter one of the following on this line; **do not** leave this line blank. The name should match the name on your tax return.

If this Form W-9 is for a joint account (other than an account maintained by a foreign financial institution (FFI)), list first, and then circle, the name of the person or entity whose number you entered in Part I of Form W-9. If you are providing Form W-9 to an FFI to document a joint account, each holder of the account that is a U.S. person must provide a Form W-9.

• **Individual.** Generally, enter the name shown on your tax return. If you have changed your last name without informing the Social Security Administration (SSA) of the name change, enter your first name, the last name as shown on your social security card, and your new last name.

Note for ITIN applicant: Enter your individual name as it was entered on your Form W-7 application, line 1a. This should also be the same as the name you entered on the Form 1040 you filed with your application.

• **Sole proprietor.** Enter your individual name as shown on your Form 1040 on line 1. Enter your business, trade, or “doing business as” (DBA) name on line 2.

• **Partnership, C corporation, S corporation, or LLC, other than a disregarded entity.** Enter the entity’s name as shown on the entity’s tax return on line 1 and any business, trade, or DBA name on line 2.

• **Other entities.** Enter your name as shown on required U.S. federal tax documents on line 1. This name should match the name shown on the charter or other legal document creating the entity. Enter any business, trade, or DBA name on line 2.

• **Disregarded entity.** In general, a business entity that has a single owner, including an LLC, and is not a corporation, is disregarded as an entity separate from its owner (a disregarded entity). See Regulations section 301.7701-2(c)(2). A disregarded entity should check the appropriate box for the tax classification of its owner. Enter the owner’s name on line 1. The name of the owner entered on line 1 should never be a disregarded entity. The name on line 1 should be the name shown on the income tax return on which the income should be reported. For

example, if a foreign LLC that is treated as a disregarded entity for U.S. federal tax purposes has a single owner that is a U.S. person, the U.S. owner’s name is required to be provided on line 1. If the direct owner of the entity is also a disregarded entity, enter the first owner that is not disregarded for federal tax purposes. Enter the disregarded entity’s name on line 2. If the owner of the disregarded entity is a foreign person, the owner must complete an appropriate Form W-8 instead of a Form W-9. This is the case even if the foreign person has a U.S. TIN.

Line 2

If you have a business name, trade name, DBA name, or disregarded entity name, enter it on line 2.

Line 3a

Check the appropriate box on line 3a for the U.S. federal tax classification of the person whose name is entered on line 1. Check only one box on line 3a.

IF the entity/individual on line 1 is a(n) . . .	THEN check the box for . . .
• Corporation	Corporation.
• Individual or • Sole proprietorship	Individual/sole proprietor.
• LLC classified as a partnership for U.S. federal tax purposes or • LLC that has filed Form 8832 or 2553 electing to be taxed as a corporation	Limited liability company and enter the appropriate tax classification: P = Partnership, C = C corporation, or S = S corporation.
• Partnership	Partnership.
• Trust/estate	Trust/estate.

Line 3b

Check this box if you are a partnership (including an LLC classified as a partnership for U.S. federal tax purposes), trust, or estate that has any foreign partners, owners, or beneficiaries, and you are providing this form to a partnership, trust, or estate, in which you have an ownership interest. You must check the box on line 3b if you receive a Form W-8 (or documentary evidence) from any partner, owner, or beneficiary establishing foreign status or if you receive a Form W-9 from any partner, owner, or beneficiary that has checked the box on line 3b.

Note: A partnership that provides a Form W-9 and checks box 3b may be required to complete Schedules K-2 and K-3 (Form 1065). For more information, see the Partnership Instructions for Schedules K-2 and K-3 (Form 1065).

If you are required to complete line 3b but fail to do so, you may not receive the information necessary to file a correct information return with the IRS or furnish a correct payee statement to your partners or beneficiaries. See, for example, sections 6698, 6722, and 6724 for penalties that may apply.

Line 4 Exemptions

If you are exempt from backup withholding and/or FATCA reporting, enter in the appropriate space on line 4 any code(s) that may apply to you.

Exempt payee code.

- Generally, individuals (including sole proprietors) are not exempt from backup withholding.
- Except as provided below, corporations are exempt from backup withholding for certain payments, including interest and dividends.
- Corporations are not exempt from backup withholding for payments made in settlement of payment card or third-party network transactions.
- Corporations are not exempt from backup withholding with respect to attorneys’ fees or gross proceeds paid to attorneys, and corporations that provide medical or health care services are not exempt with respect to payments reportable on Form 1099-MISC.

The following codes identify payees that are exempt from backup withholding. Enter the appropriate code in the space on line 4.

1—An organization exempt from tax under section 501(a), any IRA, or a custodial account under section 403(b)(7) if the account satisfies the requirements of section 401(f)(2).

- 2—The United States or any of its agencies or instrumentalities.
- 3—A state, the District of Columbia, a U.S. commonwealth or territory, or any of their political subdivisions or instrumentalities.
- 4—A foreign government or any of its political subdivisions, agencies, or instrumentalities.
- 5—A corporation.
- 6—A dealer in securities or commodities required to register in the United States, the District of Columbia, or a U.S. commonwealth or territory.
- 7—A futures commission merchant registered with the Commodity Futures Trading Commission.
- 8—A real estate investment trust.
- 9—An entity registered at all times during the tax year under the Investment Company Act of 1940.
- 10—A common trust fund operated by a bank under section 584(a).
- 11—A financial institution as defined under section 581.
- 12—A middleman known in the investment community as a nominee or custodian.
- 13—A trust exempt from tax under section 664 or described in section 4947.

The following chart shows types of payments that may be exempt from backup withholding. The chart applies to the exempt payees listed above, 1 through 13.

IF the payment is for . . .	THEN the payment is exempt for . . .
• Interest and dividend payments	All exempt payees except for 7.
• Broker transactions	Exempt payees 1 through 4 and 6 through 11 and all C corporations. S corporations must not enter an exempt payee code because they are exempt only for sales of noncovered securities acquired prior to 2012.
• Barter exchange transactions and patronage dividends	Exempt payees 1 through 4.
• Payments over \$600 required to be reported and direct sales over \$5,000 ¹	Generally, exempt payees 1 through 5. ²
• Payments made in settlement of payment card or third-party network transactions	Exempt payees 1 through 4.

¹ See Form 1099-MISC, Miscellaneous Information, and its instructions.

² However, the following payments made to a corporation and reportable on Form 1099-MISC are not exempt from backup withholding: medical and health care payments, attorneys' fees, gross proceeds paid to an attorney reportable under section 6045(f), and payments for services paid by a federal executive agency.

Exemption from FATCA reporting code. The following codes identify payees that are exempt from reporting under FATCA. These codes apply to persons submitting this form for accounts maintained outside of the United States by certain foreign financial institutions. Therefore, if you are only submitting this form for an account you hold in the United States, you may leave this field blank. Consult with the person requesting this form if you are uncertain if the financial institution is subject to these requirements. A requester may indicate that a code is not required by providing you with a Form W-9 with "Not Applicable" (or any similar indication) entered on the line for a FATCA exemption code.

A—An organization exempt from tax under section 501(a) or any individual retirement plan as defined in section 7701(a)(37).

B—The United States or any of its agencies or instrumentalities.

C—A state, the District of Columbia, a U.S. commonwealth or territory, or any of their political subdivisions or instrumentalities.

D—A corporation the stock of which is regularly traded on one or more established securities markets, as described in Regulations section 1.1472-1(c)(1)(i).

E—A corporation that is a member of the same expanded affiliated group as a corporation described in Regulations section 1.1472-1(c)(1)(i).

F—A dealer in securities, commodities, or derivative financial instruments (including notional principal contracts, futures, forwards, and options) that is registered as such under the laws of the United States or any state.

G—A real estate investment trust.

H—A regulated investment company as defined in section 851 or an entity registered at all times during the tax year under the Investment Company Act of 1940.

I—A common trust fund as defined in section 584(a).

J—A bank as defined in section 581.

K—A broker.

L—A trust exempt from tax under section 664 or described in section 4947(a)(1).

M—A tax-exempt trust under a section 403(b) plan or section 457(g) plan.

Note: You may wish to consult with the financial institution requesting this form to determine whether the FATCA code and/or exempt payee code should be completed.

Line 5

Enter your address (number, street, and apartment or suite number). This is where the requester of this Form W-9 will mail your information returns. If this address differs from the one the requester already has on file, enter "NEW" at the top. If a new address is provided, there is still a chance the old address will be used until the payor changes your address in their records.

Line 6

Enter your city, state, and ZIP code.

Part I. Taxpayer Identification Number (TIN)

Enter your TIN in the appropriate box. If you are a resident alien and you do not have, and are not eligible to get, an SSN, your TIN is your IRS ITIN. Enter it in the entry space for the Social security number. If you do not have an ITIN, see *How to get a TIN* below.

If you are a sole proprietor and you have an EIN, you may enter either your SSN or EIN.

If you are a single-member LLC that is disregarded as an entity separate from its owner, enter the owner's SSN (or EIN, if the owner has one). If the LLC is classified as a corporation or partnership, enter the entity's EIN.

Note: See *What Name and Number To Give the Requester*, later, for further clarification of name and TIN combinations.

How to get a TIN. If you do not have a TIN, apply for one immediately. To apply for an SSN, get Form SS-5, Application for a Social Security Card, from your local SSA office or get this form online at www.SSA.gov. You may also get this form by calling 800-772-1213. Use Form W-7, Application for IRS Individual Taxpayer Identification Number, to apply for an ITIN, or Form SS-4, Application for Employer Identification Number, to apply for an EIN. You can apply for an EIN online by accessing the IRS website at www.irs.gov/EIN. Go to www.irs.gov/Forms to view, download, or print Form W-7 and/or Form SS-4. Or, you can go to www.irs.gov/OrderForms to place an order and have Form W-7 and/or Form SS-4 mailed to you within 15 business days.

If you are asked to complete Form W-9 but do not have a TIN, apply for a TIN and enter "Applied For" in the space for the TIN, sign and date the form, and give it to the requester. For interest and dividend payments, and certain payments made with respect to readily tradable instruments, you will generally have 60 days to get a TIN and give it to the requester before you are subject to backup withholding on payments. The 60-day rule does not apply to other types of payments. You will be subject to backup withholding on all such payments until you provide your TIN to the requester.

Note: Entering "Applied For" means that you have already applied for a TIN or that you intend to apply for one soon. See also *Establishing U.S. status for purposes of chapter 3 and chapter 4 withholding*, earlier, for when you may instead be subject to withholding under chapter 3 or 4 of the Code.

Caution: A disregarded U.S. entity that has a foreign owner must use the appropriate Form W-8.

Part II. Certification

To establish to the withholding agent that you are a U.S. person, or resident alien, sign Form W-9. You may be requested to sign by the withholding agent even if item 1, 4, or 5 below indicates otherwise.

For a joint account, only the person whose TIN is shown in Part I should sign (when required). In the case of a disregarded entity, the person identified on line 1 must sign. Exempt payees, see *Exempt payee code*, earlier.

Signature requirements. Complete the certification as indicated in items 1 through 5 below.

1. Interest, dividend, and barter exchange accounts opened before 1984 and broker accounts considered active during 1983. You must give your correct TIN, but you do not have to sign the certification.

2. Interest, dividend, broker, and barter exchange accounts opened after 1983 and broker accounts considered inactive during 1983. You must sign the certification or backup withholding will apply. If you are subject to backup withholding and you are merely providing your correct TIN to the requester, you must cross out item 2 in the certification before signing the form.

3. Real estate transactions. You must sign the certification. You may cross out item 2 of the certification.

4. Other payments. You must give your correct TIN, but you do not have to sign the certification unless you have been notified that you have previously given an incorrect TIN. "Other payments" include payments made in the course of the requester's trade or business for rents, royalties, goods (other than bills for merchandise), medical and health care services (including payments to corporations), payments to a nonemployee for services, payments made in settlement of payment card and third-party network transactions, payments to certain fishing boat crew members and fishermen, and gross proceeds paid to attorneys (including payments to corporations).

5. Mortgage interest paid by you, acquisition or abandonment of secured property, cancellation of debt, qualified tuition program payments (under section 529), ABLE accounts (under section 529A), IRA, Coverdell ESA, Archer MSA or HSA contributions or distributions, and pension distributions. You must give your correct TIN, but you do not have to sign the certification.

What Name and Number To Give the Requester

For this type of account:	Give name and SSN of:
1. Individual	The individual
2. Two or more individuals (joint account) other than an account maintained by an FFI	The actual owner of the account or, if combined funds, the first individual on the account ¹
3. Two or more U.S. persons (joint account maintained by an FFI)	Each holder of the account
4. Custodial account of a minor (Uniform Gift to Minors Act)	The minor ²
5. a. The usual revocable savings trust (grantor is also trustee)	The grantor-trustee ¹
b. So-called trust account that is not a legal or valid trust under state law	The actual owner ¹
6. Sole proprietorship or disregarded entity owned by an individual	The owner ³
7. Grantor trust filing under Optional Filing Method 1 (see Regulations section 1.671-4(b)(2)(i)(A))**	The grantor*

For this type of account:	Give name and EIN of:
8. Disregarded entity not owned by an individual	The owner
9. A valid trust, estate, or pension trust	Legal entity ⁴
10. Corporation or LLC electing corporate status on Form 8832 or Form 2553	The corporation
11. Association, club, religious, charitable, educational, or other tax-exempt organization	The organization
12. Partnership or multi-member LLC	The partnership
13. A broker or registered nominee	The broker or nominee
14. Account with the Department of Agriculture in the name of a public entity (such as a state or local government, school district, or prison) that receives agricultural program payments	The public entity
15. Grantor trust filing Form 1041 or under the Optional Filing Method 2, requiring Form 1099 (see Regulations section 1.671-4(b)(2)(i)(B))**	The trust

¹ List first and circle the name of the person whose number you furnish. If only one person on a joint account has an SSN, that person's number must be furnished.

² Circle the minor's name and furnish the minor's SSN.

³ You must show your individual name on line 1, and enter your business or DBA name, if any, on line 2. You may use either your SSN or EIN (if you have one), but the IRS encourages you to use your SSN.

⁴ List first and circle the name of the trust, estate, or pension trust. (Do not furnish the TIN of the personal representative or trustee unless the legal entity itself is not designated in the account title.)

* **Note:** The grantor must also provide a Form W-9 to the trustee of the trust.

** For more information on optional filing methods for grantor trusts, see the Instructions for Form 1041.

Note: If no name is circled when more than one name is listed, the number will be considered to be that of the first name listed.

Secure Your Tax Records From Identity Theft

Identity theft occurs when someone uses your personal information, such as your name, SSN, or other identifying information, without your permission to commit fraud or other crimes. An identity thief may use your SSN to get a job or may file a tax return using your SSN to receive a refund.

To reduce your risk:

- Protect your SSN,
- Ensure your employer is protecting your SSN, and
- Be careful when choosing a tax return preparer.

If your tax records are affected by identity theft and you receive a notice from the IRS, respond right away to the name and phone number printed on the IRS notice or letter.

If your tax records are not currently affected by identity theft but you think you are at risk due to a lost or stolen purse or wallet, questionable credit card activity, or a questionable credit report, contact the IRS Identity Theft Hotline at 800-908-4490 or submit Form 14039.

For more information, see Pub. 5027, Identity Theft Information for Taxpayers.

Victims of identity theft who are experiencing economic harm or a systemic problem, or are seeking help in resolving tax problems that have not been resolved through normal channels, may be eligible for Taxpayer Advocate Service (TAS) assistance. You can reach TAS by calling the TAS toll-free case intake line at 877-777-4778 or TTY/TDD 800-829-4059.

Protect yourself from suspicious emails or phishing schemes.

Phishing is the creation and use of email and websites designed to mimic legitimate business emails and websites. The most common act is sending an email to a user falsely claiming to be an established legitimate enterprise in an attempt to scam the user into surrendering private information that will be used for identity theft.

The IRS does not initiate contacts with taxpayers via emails. Also, the IRS does not request personal detailed information through email or ask taxpayers for the PIN numbers, passwords, or similar secret access information for their credit card, bank, or other financial accounts.

If you receive an unsolicited email claiming to be from the IRS, forward this message to phishing@irs.gov. You may also report misuse of the IRS name, logo, or other IRS property to the Treasury Inspector General for Tax Administration (TIGTA) at 800-366-4484. You can forward suspicious emails to the Federal Trade Commission at spam@uce.gov or report them at www.ftc.gov/complaint. You can contact the FTC at www.ftc.gov/idtheft or 877-IDTHEFT (877-438-4338). If you have been the victim of identity theft, see www.IdentityTheft.gov and Pub. 5027.

Go to www.irs.gov/IdentityTheft to learn more about identity theft and how to reduce your risk.

Privacy Act Notice

Section 6109 of the Internal Revenue Code requires you to provide your correct TIN to persons (including federal agencies) who are required to file information returns with the IRS to report interest, dividends, or certain other income paid to you; mortgage interest you paid; the acquisition or abandonment of secured property; the cancellation of debt; or contributions you made to an IRA, Archer MSA, or HSA. The person collecting this form uses the information on the form to file information returns with the IRS, reporting the above information. Routine uses of this information include giving it to the Department of Justice for civil and criminal litigation and to cities, states, the District of Columbia, and U.S. commonwealths and territories for use in administering their laws. The information may also be disclosed to other countries under a treaty, to federal and state agencies to enforce civil and criminal laws, or to federal law enforcement and intelligence agencies to combat terrorism. You must provide your TIN whether or not you are required to file a tax return. Under section 3406, payors must generally withhold a percentage of taxable interest, dividends, and certain other payments to a payee who does not give a TIN to the payor. Certain penalties may also apply for providing false or fraudulent information.

PLEASE BE ADVISED!

Every party to a public contract and every party bidding on public contracts are required to have a written sexual harassment policy that contains:

- (1) a statement that sexual harassment is illegal;
- (2) a definition of sexual harassment under state law;
- (3) a description of sexual harassment utilizing examples;
- (4) an internal formalized complaint process, including penalties;
- (5) the legal recourse, investigative and complaint process available through the Department of Human Rights and the Illinois Human Rights Commission;
- (6) directions on how to contact the Illinois Department of Human Rights and Illinois Human Rights Commission – **Illinois companies. Out-of-State companies must include directions on how to contact the enforcement agency within their state.** Companies that issue a standard policy for all business locations must prepare an addendum providing directions on how to contact the appropriate enforcement agency.
- (7) a recitation that there cannot be any retaliation against employees who elect to file charges, as provided in Sections 6-101 and 6-101.5 of the Illinois Human Rights Act.

Recommendation: Your sexual harassment policy should be drafted in language easy to understand and any revisions should be reviewed by legal counsel. A copy of your policy should be posted in a prominent and accessible location to assure all employees will be notified of the company's position.

In order to conduct business with the THE PEORIA PARK DISTRICT, you must have a written sexual harassment policy that conforms to the Illinois Human Rights Act and/or the laws of your jurisdiction.

**FAILURE TO DO SO
WILL DISQUALIFY YOU AS AN ELIGIBLE VENDOR!!!**

SAMPLE ADDENDUM

Peoria Park District
Planning, Design and Construction Department
1314 N. Park Road
Peoria, IL 61604
Telephone: (309) 686-3386

ADDENDUM NO. _____

PROJECT TITLE: _____

ISSUANCE DATE: _____

LOCATION: _____

The proposed Contract Documents for this Work are modified as follows:

- I. **GENERAL INFORMATION:**

- II. **DRAWINGS:** (Delete/Change/Modify/Etc.)

- III. **PROJECT MANUAL/SPECIFICATIONS.:**
(Delete/Change/Modify/Etc.)

- IV. **INVITATION TO BID:** (Delete/Change/Modify/Etc.)

END OF ADDENDUM NO. _____

(Addendum may be bound into Project Manual, attached to front cover, faxed, mailed, emailed or delivered to bidders.)

Addendum No. _____
Page 1 of 1



Pleasure Driveway and Park District of Peoria, Illinois
Sample Agreement Between Owner and Contractor

This **AGREEMENT** for

FRONT VESTIBULE REPAIR
BRADLEY PARK - EQUIPMENT SERVICE CENTER
1314 N. PARK RD
PEORIA, IL 61604

is made as of the 13 day of May in the year of Two Thousand Twenty-Six (2026)

Between the Owner:

PLEASURE DRIVEWAY AND PARK DISTRICT OF PEORIA, ILLINOIS
1125 W. LAKE AVENUE
PEORIA, IL 61614

And the Contractor:

PLANNING, DESIGN AND CONSTRUCTION DEPARTMENT
1314 N. PARK ROAD
PEORIA, IL 61604

The Owner's Representative is:

The Architect or Engineer is:

The Owner and Contractor agree as follows:

I. THE CONTRACT DOCUMENTS. The Contract Documents consist of this AGREEMENT, the Plans/Drawings for the Project dated April 14, 2026, all sections of the Project Manual dated April 14, 2026 including but not limited to the Instructions and Supplementary Instructions to Bidders, the Bid Form, the General Conditions (2017 AIA Document A201) and Supplementary General Conditions, the General Requirements, the Specifications, and other documents as enumerated in Section 10 and Attachment #1 of this AGREEMENT, and including addenda issued prior to the execution of this AGREEMENT. The Contract Documents form the CONTRACT between the Owner and the Contractor. The CONTRACT represents the entire and integrated contract for the construction of the Work of the Project between the parties hereto and supersedes prior proposals, contracts, negotiations, or representations, either written or oral.

II. THE WORK OF THE CONTRACT. The Contractor shall execute the entire Work described in the Contract Documents, unless modified in Section XI of this AGREEMENT.

III. BASIS OF PAYMENT. The Work of the CONTRACT shall be performed on a Lump Sum basis.

IV. CONTRACT SUM. The Owner shall pay the Contractor the sum of

--

(and incorporates the acceptance of bid alternates as defined in sub-paragraph "A", below) for the Contractor's performance of the Work required by the Contract Documents, subject to modifications made by Owner approved Change Orders. If this CONTRACT calls for a unit price basis of payment, the contract sum stated above shall be adjusted by Change Order based upon multiplying the unit prices submitted by the Contractor on the Bid Form (and included herein as an Attachment to this CONTRACT) times (x) the actual quantities installed.

V. DATES OF COMMENCEMENT AND COMPLETION OF THE WORK. The Owner's Representative will issue a written Notice to Proceed with the Work of the Project after receiving the required Performance Bond, Labor and Material Payment Bond, and Certificate of Insurance (in proper form and providing the required coverages and amounts from a company [or companies] acceptable to the Owner, and naming the Owner as an Additional Insured), and any other pre-construction submittals required by the Contract Documents. The Contractor hereby acknowledges and agrees that failure to provide such submittals in a timely manner shall not be cause to adjust the date(s) for completion of the Work.

- A. LIQUIDATED DAMAGES.** Owner and Contractor recognize that time is of the essence of this CONTRACT and that Owner will suffer financial loss if the Contractor has not achieved Substantial Completion and Final Completion of the Work within the time specified below, plus any extensions thereof allowed in accordance with Article 8 of the General Conditions. They also recognize the delays, expense and difficulties involved in proving in a legal or arbitration proceeding the actual loss suffered by Owner if the Work is not completed on time.
- B. SUBSTANTIAL COMPLETION.** Accordingly, instead of requiring any such proof, Owner and Contractor agree that as Liquidated Damages for delay (but not as a penalty), Contractor shall pay Owner Two hundred fifty dollars (\$250.00) for each calendar day that expires after One Hundred Forty (140) calendar days from Notice of Award until Substantial Completion is attained. The work is tentatively scheduled to begin on May 14, 2026 and be at Substantial Completion by September 30, 2026.
- C. FINAL COMPLETION.** After Substantial Completion if Contractor shall neglect, refuse, or fail to complete the remaining Work necessary to achieve Final Completion within fourteen (14) calendar days or any proper extension thereof granted by Owner, Contractor shall pay Owner Two Hundred Fifty dollars (\$250.00) for each day that expires after the time specified.

VI. PROGRESS PAYMENTS, REDUCTION OF RETAINAGE AND FINAL PAYMENT.

- A.** Unless otherwise specified elsewhere in the Contract Documents, the Contractor may submit monthly applications for progress payments ("Application for Payment") to the Owner's Representative. Each Application for Payment must be certified by the Architect or Engineer (if applicable), or the Owner's Representative if an Architect or Engineer has not been engaged for construction phase services. An Application for Payment shall be for a period of no less than one calendar month ending on the last day of the month, unless otherwise approved in writing by the Owner's Representative. Application forms shall be subject to Owner's approval. Each Application for Payment shall be based upon the Schedule of Values submitted by the Contractor, in accordance with the Contract Documents. The Schedule of Values shall be approved by the Owner's Representative and the Architect or Engineer (if applicable) in advance of the Contractor's first Application for Payment and the approved schedule shall be used by the Contractor as the basis for submitting payment requests. The Owner's Representative and/or Architect/Engineer's (if applicable) approval of the Schedule of Values shall not constitute a complete check for accuracy, and shall not relieve the Contractor from responsibility for errors of any sort.
- B.** An Application for Payment (certified by the Architect or Engineer, if applicable) shall be submitted to the Owner's Representative no later than the fifth (5th) day of the month following the period for which the application is being submitted. In such case, the Owner shall make the progress payment to the Contractor not later than the twentieth day of the next month. A progress payment request on an Application for Payment (certified by the Architect or Engineer, if applicable) received by the Owner's Representative after the fifth (5th) day of a month shall be made by the Owner not later than forty-five days after receipt by the Owner's Representative.
- C.** Based upon its review of the certified (by the Architect or Engineer, if applicable) Application for Payment, the Owner shall make a progress payment to the Contractor in such amount as the Owner reasonably determines is properly due, subject to a retainage of ten percent (10%) of the value of the Work completed and covered by the Application for Payment, less the aggregate of previous payments in each case. In determining the amount properly due, the Owner shall consider the value of labor, materials and equipment incorporated in the Work, or properly

allocable to materials and equipment suitably stored at the site or at some other location previously agreed upon in writing by the parties. The Owner's Representative shall have the sole right to determine that materials or equipment stored off-site have been properly delivered, protected, and/or secured. The Owner's Representative (or the Architect or Engineer, if applicable) may nullify or withhold a Certificate of Payment, in whole or in part, for the reasons set forth in Section 9.5 of the General Conditions. Upon Substantial Completion of the Work, the Owner shall pay the Contractor a sum sufficient to increase the total payments to ninety-five percent (95%) of the Contract Sum, less such amounts as the Owner's Representative shall determine for incomplete work and unsettled claims.

VII. Final payment, constituting the entire unpaid balance of the Contract Sum, shall be made by the Owner when **1)** the Contract has been fully performed by the Contractor except for the Contractor's responsibility to correct nonconforming Work as provided in Subparagraph 12.2.2 of the General Conditions and to satisfy other requirements, if any, which necessarily survive final payment; and **2)** a final Certificate of Payment has been issued by the Architect/Engineer or Owner's Representative; such final payment shall be made by the Owner not more than forty-five (45) days after the receipt of the final Certificate of Payment by the Owner.

VIII. CHANGE ORDERS. The Owner and Contractor agree that changes in the Work are sometimes required and necessary, and that timely: **a)** submission of proposed changes in the Work or the scope of Work by the Owner, **b)** pricing by the Contractor, **c)** review by the Owner's Representative and/or Architect/Engineer, and **d)** final approval by the Owner are necessary in order to assure that the Work of the Project is completed on schedule. The Contractor hereby acknowledges and agrees that an increase in the scope of the Work does not grant or imply an increase in the Contract Time, unless specifically so stated on the final approved Change Order. The Contractor also agrees that any and all Work which deviates from the plans and specifications and/or results in additional Work performed by Contractor's forces, including those of his sub-contractor's, will not result in additional expense to the Owner, unless finally approved both by the Owner and the Architect/Engineer (if applicable) prior to the additional Work being performed. No claim for an addition to the Contract Sum shall be valid unless approved by a written Change Order signed by the Owner and the architect/engineer (if applicable) prior to the additional Work being performed.

IX. TERMINATION OR SUSPENSION. The CONTRACT may be terminated by the Owner or the Contractor as provided by Article 14 of the General Conditions. The Work may be suspended by the Owner as provided in Article 14 of the General Conditions.

X. ENUMERATION OF CONTRACT DOCUMENTS. The Contract Documents, except for modifications issued after the execution of this Agreement, consist of:

- A. this Standard Form of Agreement Between Owner and Contractor, of the Pleasure Driveway and Park District of Peoria, Illinois.
- B. the Plans or Drawings titled Front VESTIBULE REPAIR BRADLEY PARK EQUIPMENT SERVICE CENTER, dated April 14, 2026 and enumerated in ATTACHMENT #1 - "LIST OF DRAWINGS".
- C. Supplementary and other Conditions of the CONTRACT, and the Specifications, are those found in the Project Manual titled "FRONT VESTIBULE REPAIR BRADLEY PARK – EQUIPMENT SERVICE CENTER", and dated April 14, 2026, enumerated as follows:
 - 1) Supplementary Instructions to Bidders
 - 2) Contractor's Proposal, as accepted by the Owner
 - 3) General Conditions of the Contract for Construction, AIA Document A201, 2017 Edition
 - 4) Supplementary General Conditions
 - 5) Subcontractor List
 - 6) Certification of Compliance for Listed Provisions and Laws
 - 7) Company Ownership Certification
 - 8) Peoria Park District Certificate of Equal Employment Opportunity Compliance for Contractors and Vendors
 - 9) Workforce Profile
 - 10) Minority/Women Owned Contact Sheet, if bid is over \$50,000.00
 - 11) Contractor/Subcontractor Workforce Plan, if bid is over \$50,000.00
 - 12) Performance Bond
 - 13) Labor and Material Payment Bond
 - 14) Proof of Insurance
 - 15) Specifications: Division 010000, "General Requirements"; Divisions 020000-350000 as applicable
 - 16) Attachment A.6 - Insurance Requirements

- 17) Attachment B – Solicitation & Hiring for Qualifying Construction Contracts & Forms
- 18) Attachment C – Directory of Minority & Women Owned Business Enterprises
- 19) Attachment D – IDOL Prevailing Wages of Peoria County
- 20) Proof of Certified Payroll Submitted to IDOL per “The Illinois Prevailing Wage Act”

XI. MISCELLANEOUS PROVISIONS. Other Provisions of this Agreement are as follows:

This AGREEMENT is entered into as of the day and year first written above and is executed in at least three original copies of which one is to be delivered to the Contractor, one to the Architect/Engineer (if any) for use in the administration of the CONTRACT, and one to the Owner.

OWNER:

CONTRACTOR:

(Signature)

(Signature)

ROBERT L. JOHNSON, SR., Park Board President

(Printed Name and Title)

ATTEST:

ATTEST:

ATTACHMENT #1 - LIST OF DRAWINGS

<u>Number</u>	<u>Title</u>	<u>Date</u>
G1	Title Sheet	04-14-2026
A1	Existing / Revised Plans & Elevation	04-14-2026
A2	Existing Elevation Pics & Notes	04-14-2026
A3	Existing Interior Elevation Pics & Notes	04-14-2026
A4	Exterior Elevation/ Building Section	04-14-2026
A5	Building Section / Framing Details	04-14-2026

PERFORMANCE BOND

**TO: PLEASURE DRIVEWAY AND PARK DISTRICT OF PEORIA
PEORIA, ILLINOIS**

KNOW ALL MEN BY THESE PRESENTS;

That _____
_____ as Principal, and _____
_____ as
corporation of the State of _____, as Surety, are held and firmly bound unto the
PLEASURE DRIVEWAY AND PARK DISTRICT OF PEORIA, PEORIA, ILLINOIS, as Obligee, in the amount of _____
(\$ _____), for the payment whereof Principal and Surety bind themselves, their heirs, executors, administrators,
successors and assigns, jointly and severally, firmly by these presents.

WHEREAS, Principal has by written agreement dated _____, 20 _____ entered into a contract
with Obligee for _____

_____ in accordance with contract documents prepared by the Architect-Engineer, which Contract is by reference made a part hereof and
is hereinafter referred to as "the Contract".

NOW, THEREFORE, THE CONDITION OF THIS OBLIGATION is such that if Principal shall promptly and faithfully
perform the Contract and all changes thereof, and during the life of any guaranty or warranty required under the Contract, and, if
Principal shall fully secure and protect the Obligee from all liability and from all loss or expense of any kind, including all court
costs, engineering fees and attorneys' fees made necessary or arising from the failure, refusal or neglect of Principal to comply with
all obligations assumed by Principal in connection with the performance of the Contract and all changes thereof, then this
obligation shall be null and void; otherwise it shall remain in full force and effect.

Surety hereby waives notice of any changes in the Contract, including extensions of time for the performance thereof. Whenever
Principal shall be and is declared to be in default under the Contract, Obligee having performed Obligee's obligations thereunder,
Surety shall, after notice of such default, reserve all rights against all parties, take over and complete the Contract and become
entitled to payment of the balance of any monies due or to become due to such defined Principal in accordance with the progress
of the work.

A condition of this Bond is that the Principal shall faithfully perform in accordance with the prevailing wage clause provided in the
bid specification or Contract pursuant to Illinois Compiled Statutes 820 ILCS 130/1 *et. seq.*

No right of action shall accrue on this Bond to or for the use of any person or corporation other than the Obligee named
herein.

Signed and Sealed this _____ day of _____, 20 _____.

CONTRACTOR

Contractor Firm Name

By: _____
Signature

Title

SURETY

Surety Name

By: _____
Attorney-in-Fact

Resident Agent

ATTEST:

Corporate Secretary (Corporations only)

LABOR & MATERIAL PAYMENT BOND

**TO: PLEASURE DRIVEWAY AND PARK DISTRICT OF PEORIA
PEORIA, ILLINOIS**

KNOW ALL MEN BY THESE PRESENTS:

That: _____

_____ as Principal, and _____

_____ a corporation of the State of _____ as Surety, are held and firmly bound unto the PLEASURE DRIVEWAY AND PARK DISTRICT OF PEORIA, PEORIA, ILLINOIS, as Obligee, for the use and benefit of claimants as hereinafter defined in the amount of _____ Dollars (\$ _____), for the payment whereof Principal and Surety bind themselves, their heirs, executors, administrators, successors and assigns, jointly and severally, firmly by these presents.

WHEREAS, Principal has by written agreement dated _____, 20 _____, entered into a Contract with Obligee for _____

_____ in accordance with contract documents prepared by the Architect-Engineer which Contract is by reference made a part hereof, and is hereinafter referred to as "the Contract".

NOW, THEREFORE, THE CONDITION OF THIS OBLIGATION is such that if Principal shall promptly pay for all laborers, workers and mechanics engaged in the work under the Contract, and not less than the general prevailing rate of hourly wages of a similar character in the locality in which the work is performed, as determined by the State of Illinois Department of Labor pursuant to the Illinois Compiled Statutes 820 ILCS 130/1 et. seq. and for all material used or reasonably required for use in the performance of the Contract, then this obligation shall be void; otherwise it shall remain in full force and effect.

1. A claimant is defined as any person, firm, or corporation having contracts with the Principal or with any of Principal's subcontractors for labor or materials furnished in the performance of the Contract on account of which this Bond is given.
2. Nothing in this Bond contained shall be taken to make the Obligee liable to any subcontractor, materialman or laborer, or to any other person to any greater extent than it would have been liable prior to the enactment of The Public Construction Bond Act, approved June 20, 1931, as amended; provided further, that any person having a claim for labor and materials furnished in the performance of the Contract shall have no right of action unless he shall have filed a verified notice of such claim with the Obligee within 180 days after the date of the last item of work or the furnishing of the last item of materials, which claim shall have been verified and shall contain the name and address of the claimant, the business address of the claimant within the State of Illinois, if any, or if the claimant be a foreign corporation having no place of business within the State the principal place of business of the corporation, and in all cases of partnership the names and residences of each of the partners, the name of the Contractor for the Obligee, the name of the person, firm or corporation by whom the claimant was employed or to whom such claimant furnished materials, the amount of the claim and a brief description of the public improvement for the construction or installation of which the Contract is to be performed. No defect in the notice herein provided for shall deprive the claimant of its right of action under the terms and provisions of this Bond unless it shall affirmatively appear that such defect has prejudiced the rights of an interested party asserting the same.
3. No action shall be brought on this Bond until the expiration of 120 days after the date of the last item of work or of the furnishing of the last item of material except in cases where the final settlement between the Obligee and the Contractor shall have been made prior to the expiration of the 120 day period, in which case action may be taken immediately following such final settlement; nor shall any action of any kind be brought later than 6 months after the acceptance by the Obligee of the work. Such suit shall be brought only in the circuit court of this State in the judicial district in which the Contract is to be performed.
4. Surety hereby waives notice of any changes in the Contract, including extensions of time for the performance thereof.

5. The amount of this Bond shall be reduced by and to the extent of any payment or payments made in good faith hereunder.

6. The Principal and Surety shall be liable for any attorneys fees, engineering costs, or court costs incurred by the Obligee relative to claims made against this Bond.

Signed and sealed this _____ day of _____, 20 _____.

CONTRACTOR

SURETY

Contractor Firm Name:

By: _____
Signature

By: _____
Attorney-in-Fact

Title

Resident Agent

ATTEST:

Corporate Secretary (Corporations only)

CONTRACTOR'S AFFIDAVIT

STATE OF ILLINOIS)
) SS
COUNTY OF PEORIA)

TO WHOM IT MAY CONCERN:

THE undersigned, being duly sworn, deposes and says that he is _____
_____ of the _____
who is the contractor for the _____
building located at _____
owned by _____.

That the total amount of the contract including extras is \$_____ on which he has received payment
of \$_____ prior to this payment. That all waivers are true, correct and genuine and delivered
unconditionally and that there is no claim either legal or equitable to defeat the validity of said waivers. That the following are the
names of all parties who have furnished material or labor, or both, for said work and all parties having contracts or sub-contracts
for specific portions of said work or for material entering into the construction thereof and the amount due or to become due to
each, and that the items mentioned include all labor and material required to complete said work according to plans and
specifications:

NAMES	WHAT FOR	CONTRACT PRICE	AMOUNT PAID	THIS PMT.	BALANCE DUE

TOTAL ALL LABOR AND MATERIAL TO COMPLETE

There are no other contracts for said work outstanding, and that there is nothing due or to become due to any person for material,
labor or other work of any kind done or to be done upon or in connection with said work other than above stated.

Signed this _____ day of _____, 20 _____.

Signature: _____

Subscribed and sworn to before me this _____ day of _____, 20 _____.

Notary Public

FINAL WAIVER OF LIEN

STATE OF ILLINOIS)
) SS
COUNTY OF PEORIA)

TO WHOM IT MAY CONCERN:

WHEREAS, the undersigned _____ ha _____ been employed by THE PEORIA PARK DISTRICT to furnish material and labor for the _____ at the premises commonly known as _____ located in the City of _____, County of Peoria, State of Illinois.

The undersigned, for and in consideration of _____ (\$ _____) Dollars, and other good and valuable considerations, the receipt whereof is hereby acknowledged, do _____ hereby waive and release any and all lien or claim or right of lien under the statutes of the State of Illinois relating to mechanics' liens, with respect to and on said above-described premises and improvements thereon and on the money, funds or other considerations due or become due from the owner on account of labor or services, material, fixtures, apparatus or machinery heretofore furnished or which may be furnished at any time hereafter by the undersigned for the above described premises.

Dated this _____ day of _____ 20 _____.

[Affix corporate seal here.]

(Name of sole owner, corporation or partnership)

ATTEST:

(Signature of secretary of corporation)

(SEAL)
(Signature of sole owner or authorized representative of corporation or partnership)

WAIVER OF LIEN

**GENERAL CONTRACTOR'S PARTIAL
TO COVER ONLY CERTAIN PAYMENTS**

STATE OF ILLINOIS)
) SS
COUNTY OF PEORIA)

TO ALL WHOM IT MAY CONCERN:

WHEREAS, the undersigned _____ has been employed
by THE PEORIA PARK DISTRICT to furnish material and labor for the _____ at
the premises commonly known as _____

located in the City of Peoria, County of Peoria, and State of Illinois.

NOW, THEREFORE, the undersigned, for and in consideration of the sum of _____
_____ Dollars, and other good and valuable considerations, the receipt
whereof is hereby acknowledged by the undersigned, does hereby waive and release to the extent only of the aforesaid amount of
_____ Dollars, paid simultaneously herewith, any and all lien or right or claim of
lien under the statutes of the State of Illinois relating to mechanics' liens, with respect to and on said above-described premises,
and the improvements thereon and on the money, funds, or other consideration due or to become due from the owner on account of
labor, services, material, fixtures, apparatus or machinery, furnished by the undersigned, to or on account of the said owner, for the
above-described premises, but only to the extent of the payment aforesaid.

Dated this _____ day of _____, 20 _____.

[Affix corporate seal here]

(Name of sole owner, corporation or partnership)

ATTEST:

(Signature of secretary of corporation)

_____ (SEAL)
(Signature of sole owner or authorized
representative of corporation or partnership)

A complete copy of AIA Document A201, 2017 Edition, with Supplementary General Conditions incorporated, is available for review in the Peoria Park District's Planning, Design and Construction Office.

SUPPLEMENTARY GENERAL CONDITIONS

1. A. **"GENERAL CONDITIONS OF THE CONTRACT FOR CONSTRUCTION"**, AIA Document A201, 2017 Edition, published by the American Institute of Architects, including revisions adopted before the date of the Project Manual, is hereby made part of these Specifications with same force and effect as though set forth in full.
- B. The following modifies, changes, deletes from or adds to the General Conditions of the Contract for Construction (AIA Document A201, Sixteenth Edition, 2017). Where any Article of the General Conditions is modified or any Paragraph, Subparagraph or Clause thereof is modified or deleted by these Supplementary Conditions, the unaltered provisions of that Article, Paragraph, Subparagraph or Clause shall remain in effect.
- C. Parenthesis () indicates the appropriate section and Subparagraph of the General Conditions which each paragraph of the Supplementary General Conditions modifies or refers to.

ARTICLE 1: GENERAL PROVISIONS

1.1 - Basic Definitions

INSERT THE FOLLOWING PHRASE TO PARAGRAPH (1.1.1) AFTER THE WORDS "The Contract Documents consist of the Agreement Between Owner and Contractor (hereinafter the Agreement) and consists of the Agreement,":

“the Contractor's Bid, the Advertisement for Bids, the Instructions to Bidders, sample forms and addenda relating to these,”

DELETE THE LAST SENTENCE OF PARAGRAPH (1.1.1).

PARAGRAPH (1.1.8) IN THE HEADING DELETE “Initial Decision Maker” SUBSTITUTE “Initial Recommendation Maker”

PARAGRAPH (1.1.8) DELETE “Initial Decision Maker” AND SUBSTITUTE “Initial Recommendation Maker”

IN PARAGRAPH (1.1.8) REPLACE “decisions” WITH “recommendations”.

1.2 - Correlations and intent of the Contract Documents

ADD THE FOLLOWING SENTENCES TO END OF PARAGRAPH (1.2.1):

The Contractor shall notify the Owner’s Representative immediately if discrepancies are discovered. Full-size or large-scale details or drawings shall govern small-scale drawings that the former are intended to amplify. Dimensions from drawings shall not be determined by scale or rule. Where the Drawings and Specifications conflict with each other or with themselves, the Owner’s Representative (in consultation with the Architect, if any) will decide which conflicting requirement governs. Should discrepancies or doubt occur, Contractor shall not proceed with the Work without clarification from the Owner. Contractor shall request clarification in a reasonable time to avoid delays and increases in the Contract Sum.

ADD THE FOLLOWING PARAGRAPHS TO SECTION (1.2):

- 1.2.4** If any item or material shown on the Drawings is omitted from the Specifications, or vice-versa (except when the Drawings and Specifications clearly exclude such omitted item), and when such item or material is clearly required to complete the detail shown or specified, the Contractor shall furnish and install such item or material of the type and quality established by the balance of the detail shown and specified at no increase to the Contract Sum.
- 1.2.5** Where a typical or representative detail is shown on the Drawings, this detail shall constitute the standard for workmanship and materials throughout those parts of the Work.
- 1.2.6** Any Summary of Work as outlined in the Specifications shall not be deemed to limit the work required by the Contract Documents. The Contractor and each Subcontractor shall be responsible for carefully examining all Drawings, including all details, plans, elevations, sections, schedules and diagrams for each particular type of work, and for coordinating the Work described in the Drawings, with the related Specifications. The Contractor shall also be responsible for determining the exact scope of work for each type of work per the Contract Documents and Contractor shall endeavor to check cross-references of work excluded from any division. The Contract Sum is deemed to be based on a complete installation. When additional details or instructions are clearly required to complete the work, the Contractor is deemed to have made an allowance in the Contract Sum for completion of such Work consistent with the local standard of care.
- 1.2.7** The Drawings are intended to show the arrangement, design and extent of the Work and are schematic in nature. They are not to be scaled for roughing-in measurements or used as shop drawings.

1.5 – Ownership and Use of Drawings, Specifications, and Other Instruments of Service

ADD THE FOLLOWING PARAGRAPH TO SECTION (1.5):

- 1.5.3** Neither any oral representation by or oral agreement with any officer, agent, or employee of Owner or Architect before execution of this Contract shall affect or modify any of the Contractor's rights or obligations hereunder. Contractor is not aware of any facts that make misleading or inaccurate in any material respect any information Owner or Architect has furnished to Contractor which would have a material adverse affect on the Contract Time or Contract Sum which Contractor has not advised Owner or Architect of, and if, during the course of the performance of the Work, Contractor learns of any such facts it will so advise Owner. Contractor shall not be entitled to any adjustments in the Contract Time or the Contract Sum as a consequence of Contractor's breach of the terms of this Subparagraph.

1.7 – Digital Data use and Transmission

DELETE THE SECOND SENTENCE IN PARAGRAPH (1.7).

1.8 – Building Information Models Use and Reliance

DELETE PARAGRAPH (1.8) IN ITS ENTIRETY.

ARTICLE 2: OWNER

2.3 – Information and Services Required of the Owner

DELETE PARAGRAPH (2.3.4) IN ITS ENTIRETY.

2.4 – Owner’s Right to stop the Work

ADD THE FOLLOWING SENTENCE AT THE END OF PARAGRAPH (2.4):

“The Owner shall not be liable for any extra cost incurred by the Contractor by such an order.”

2.5 – Owner’s Right to Carry Out the Work

IN PARAGRAPH (2.5), IN THE SECOND SENTENCE, DELETE “Such action by the Owner and amounts charged to the Contractor are both subject to prior approval of the Architect and”.

ARTICLE 3: CONTRACTOR

3.2 - Review of Contract Documents and Field Conditions by Contractor

IN PARAGRAPH (3.2.2, 3.2.3, AND (3.2.4) AFTER THE WORD “Architect” ADD THE WORDS “and Owner”.

ADD THE FOLLOWING PARAGRAPH TO SECTION (3.2):

3.2.5 Before starting any work, the Contractor shall examine work performed by others to which his work adjoins or is applied to and report to the Owner's Representative any conditions that will prevent the satisfactory accomplishment of his work. Failure to notify the Owner's Representative of deficiencies or faults in preceding work prior to commencing work shall constitute acceptance thereof and waiver of any claim of its unsuitability.

3.4 – Labor and Materials

ADD THE FOLLOWING PARAGRAPHS TO SECTION (3.4):

3.4.4 Before ordering any material or doing any Work, the Contractor shall verify all measurements at the Project site and he shall be responsible for the correctness of same. No extra charge or compensation will be allowed to the Contractor on account of any difference between actual dimensions and the measurements shown on the Project Drawings.

3.4.5 The Contractor shall carefully inspect all materials delivered on and to the Project site and reject defective materials without waiting for the Owner's Representative or other representative of Owner to observe the materials.

3.5 - Warranty

ADD THE FOLLOWING PARAGRAPHS TO SECTION (3.5):

3.5.3 The Contractor agrees to assign to the Owner any and all manufacturer’s warranties relating to materials and equipment furnished as part of the Work and further agrees to perform the Work in such manner so as to preserve any and all such manufacturer’s warranties subject to installation directives and other terms of the Contract Documents. The Contractor agrees to deliver to the Owner, upon final payment, such assignments along with or as part of a reference manual, in form and detail reasonably acceptable to Owner, showing all such warranties and guarantees provided by

the Contractor and Subcontractors. Such warranties and guarantees shall commence no sooner than the date of purchase from the supplier.

3.5.4 The warranty of Contractor provided in Paragraph 3.5 shall in no way limit or abridge the warranties of the suppliers of equipment and systems which are to comprise a portion of the Work, if they are broader, and all of such warranties shall be in form and substance as required by the Contract Documents. Contractor shall take no action or fail to act in any way which results in the termination or expiration of such third-party warranties or which otherwise results in prejudice to the rights of the Owner under such warranties subject to installation directives and other terms of the Contract Documents. Contractor agrees to provide all notices required for the effectiveness of such warranties and shall include provisions in the contracts with the providers and manufacturers of such systems and equipment whereby Owner shall have a direct right of enforcement of such warranty obligations.

3.6 - Taxes

IN PARAGRAPH (3.6), DELETE THE WORD "Sales".

ADD THE FOLLOWING AT THE END OF PARAGRAPH (3.6):

The Peoria Park District is exempt from Federal, State and Local taxes. A certificate of exemption will be furnished upon request.

3.10 - Contractor's Construction and Submittal Schedules

IN PARAGRAPH (3.10.2), IN THE FIRST SENTENCE BEFORE THE WORD "Architect's approval" ADD THE WORDS "Owner's and".

IN PARAGRAPH (3.10.2), IN THE SECOND SENTENCE BEFORE THE WORD "Architect's" ADD THE WORDS "Owner's and".

IN PARAGRAPH (3.10.2), IN THE THIRD SENTENCE BEFORE THE WORD "Architect" ADD THE WORDS "Owner's Representative and".

ADD THE FOLLOWING PARAGRAPHS TO SECTION (3.10):

3.10.4 The construction schedule shall provide for the most expeditious and practicable execution of the Work. The Contractor shall also work closely with the Owner to confirm that the construction schedule accurately reflects the status of the Project. The Contractor's construction schedule shall be updated every month by the Contractor and submitted to the Owner.

.1 Whenever it becomes apparent from the updated construction schedule that any substantial completion previously established by the construction schedule cannot be met, the Contractor shall, at the Owner's request, take any or all of the following actions with no increase to the Contract Sum or Contract Time (unless the delay is caused by an event set forth in paragraph 8.3 of these General Conditions thereby permitting adjustment of the Contract Sum and/or Contract Time:

.1.1 Increase construction manpower to substantially return the Project to schedule;

.1.2 Increase the number of working hours per shift, shifts per day or the amount of construction equipment or any combination of the foregoing which will substantially return the Project to schedule;

- .1.3** Reschedule activities to concurrently accomplish activities, to the maximum degree practicable, in the time required by the Contract Documents.

If the Contractor fails to take any of these actions Owner shall have the notice and other rights set forth in Paragraph 2.5.

ARTICLE 4: ARCHITECT

4.1 - General

IN PARAGRAPH (4.1.1) DELETE THE FIRST SENTENCE AND SUBSTITUTE THE FOLLOWING:

"The Architect, Owner's Representative, and Owner's Project Manager are defined in Paragraph C of "Section 014200 - General" of "Division 010000 - General Requirements".

4.2 – Administration of the Contract

IN PARAGRAPH (4.2.1) DELETE THE WORDS “and will be an Owner’s Representative”.

IN PARAGRAPH (4.2.5) DELETE THE WORD “Architect’s” AND “Architect”AND SUBSTITUTE THE WORDS “Owner Representative’s” AND “Owner Representative”.

IN PARAGRAPH (4.2.6) IN THE SECOND SENTENCE AFTER THE WORDS “will have authority” INSERT THE WORDS “upon written authorization from the Owner”.

IN PARAGRAPH (4.2.8) DELETE THE WORD “prepare” AND SUBSTITUTE THE WORDS “assist the Owner’s Representative in preparing”.

IN PARAGRAPH (4.2.9) DELETE THE WORD “Architect” AND SUBSTITUTE WORDS “Owner’s Representative, assisted by the Architect”.

IN PARAGRAPH (4.2.11) IN THE FIRST SENTENCE DELETE THE WORDS “and decide”.

IN PARAGRAPH (4.2.12) IN THE FIRST SENTENCE DELETE THE WORD “and decisions”.

IN PARAGRAPH (4.2.12) IN THE SECOND SENTENCE DELETE THE WORDS “and initial decisions” AND “or decisions”.

ADD PARAGRAPH TO SECTION (4.2):

4.2.15 Notwithstanding any other provision of this Agreement to the contrary, the Architect shall have no authority to order or approve any material deviation from the Contract Documents, whether or not such deviation affects the Contract Sum or other Substantial Completion Date (as defined herein). In the event any such deviation is sought, prior written approval from the Owner’s Representative and the Owner must be obtained. The Architect may decide quality issues and may approve non-material deviations from the Contract Documents.

ARTICLE 5: SUBCONTRACTORS

5.2 – Award of Subcontracts and Other Contracts for Portions of the Work

IN PARAGRAPH (5.2.1) DELETE THE FIRST SENTENCE AND SUBSTITUTE:

“The subcontractors/suppliers listed by the Contractor on the Subcontractor/Supplier List (submitted with the Bid) shall not be changed without the written consent of the Owner.”

IN PARAGRAPH (5.2.1) IN THE SECOND SENTENCE DELETE THE WORDS “Architect” AND SUBSTITUTE THE WORDS “Owner’s Representative”.

IN PARAGRAPH (5.2.1) IN THE LAST SENTENCE DELETE THE WORDS “Architect” AND SUBSTITUTE THE WORDS “Owner’s Representative”.

ARTICLE 6: CONSTRUCTION BY OWNER OR BY SEPARATE CONTRACTORS

6.2 – Mutual Responsibility

IN PARAGRAPH (6.2.2) BEFORE THE WORD “Architect” ADD THE WORDS “Owner and”.

6.3 – Owner’s Right to Clean Up

IN PARAGRAPH (6.3) DELETE THE WORD “Architect” AND SUBSTITUTE THE WORD “Owner”.

ARTICLE 7: CHANGES IN THE WORK

7.2 – Change Orders

IN PARAGRAPH (7.2.1) DELETE THE WORDS “the Architect” AND SUBSTITUTE THE WORDS “the Owner’s Representative”.

ADD THE FOLLOWING PARAGRAPHS TO SECTION (7.2):

7.2.2 A Change Order shall include all of the Contractor’s costs associated therewith.

7.2.3 The Contractor shall not accept any request for a Change Order from any person other than the Owner and may not perform any work asserted to constitute a change in the Work until the Owner has approved the Change Order in writing, unless the Owner authorizes the Contractor, in writing, to proceed with a change prior to the Owner’s final approval. Notwithstanding anything to the contrary herein, the Contractor shall not charge for overtime services in the performance of any Change Order Work, unless the Owner has specifically authorized overtime in writing. Owner may competitively bid changes in the Work and Contractor, Subcontractor and suppliers shall provide Owner with all documents Owner requests to facilitate such competitive bidding of changes in the Work.

7.2.4 There shall be no change in the Work, whether an alteration or addition to the Contract Sum or to any amounts due under the Contract Documents or to a change in the Contract Time, unless and until such alteration or addition has been authorized by a written Change Order executed and issued in accordance and compliance with the requirements with this Article 7 or by written authorization to proceed with such change in the Work signed by the Owner or as otherwise provided pursuant to the Contract Documents. The requirements set forth in this Paragraph 7.2.4 are of the essence. No claim that the Owner has been unjustly enriched by any alteration or addition to the Work, whether or not any such unjust enrichment to the Work or to the Owner in fact exists, shall form the basis of any claim for an increase in any amount due under the Contract Documents or a change in the Contract Time, and the terms of a fully-executed Change Order shall be conclusive.

7.3 – Construction Change Directives

IN PARAGRAPH (7.3.1) DELETE THE WORDS “the Architect” AND SUBSTITUTE THE WORDS “the Owner’s Representative”.

IN PARAGRAPH (7.3.4) DELETE THE WORD “determine” AND SUBSTITUTE THE WORD “recommend”.

IN PARAGRAPH (7.3.6) DELETE THE WORD “Architect” ADD SUBSTITUTE THE WORDS “Owner’s Representative”.

IN PARAGRAPH (7.3.8) IN THE FIRST SENTENCE AFTER THE WORD “Architect” ADD THE WORDS “and the Owner’s Representative”.

IN PARAGRAPH (7.3.9) DELETE THE WORDS “Architect” AND “Architect’s” AND SUBSTITUTE THE WORDS “Owner’s Representative” and “Owner’s Representative’s”.

IN PARAGRAPH (7.3.10) DELETE THE WORD “determination” AND SUBSTITUTE THE WORD “recommendation”.

ARTICLE 8: TIME

8.1 - Definitions

IN PARAGRAPH (8.1.3) DELETE THE WORD “Architect” AND SUBSTITUTE THE WORDS “Owner’s Representative”.

8.2 – Progress and Completion

ADD THE FOLLOWING PARAGRAPHS TO SECTION (8.2) .

8.2.4 All work shall be "Substantially Complete" as required by the **Instructions to Bidders** and the **Agreement Between Owner and Contractor**.

8.2.5 It is further agreed that said completion schedule is reasonable, and the Contractor shall prosecute said work regularly, diligently and continuously at such rate of progress as will insure full completion thereof within the time specified.

8.2.6 Provided, however, the following exceptions:

- .1** Any preference, priority or allocation order duly issued by the United States Government.
- .2** Any unforeseeable cause beyond the control and without the fault or negligence of the Contractor, including acts of God, or of a public enemy, acts of the Owner, acts of another Contractor in performance of a separate contract with the Owner, fire, floods, epidemics, quarantine restrictions, strikes, freight embargoes and unusually severe weather. The criteria on which the unusually severe weather shall be based is the average precipitation/temperatures received in the project area, as recorded over a period of the last five (5) years at the local area United States Weather Station. Any extension of time due to unusually severe weather must be requested by the Contractor on the basis of documented records of the actual precipitation/temperatures during the contract time period, compared with the normal/average for the area. Also, the criteria shall include the number of excessive precipitation or extreme cold days (i.e., days in which the temperature would adversely affect the type of work being

constructed) over the same period and whether or not the Contractor's force worked on said days or stage of construction was affected.

.3 Any delays of subcontractors occasioned by any of the causes specified in this paragraph.

8.2.7 Provided further that the Contractor shall, within seven (7) days from the beginning of any such delay during the performance of the Contract, notify the Owner's Representative in writing of the alleged cause of such delay.

8.3 – Delays and Extensions of Time

IN PARAGRAPH (8.3.1) DELETE THE WORDS “and binding dispute resolution”.

IN PARAGRAPH (8.3.1) DELETE THE WORD “determine” AND SUBSTITUTE THE WORD “recommend”.

ARTICLE 9: PAYMENTS AND COMPLETION

9.2 – Schedule of Values

DELETE PARAGRAPH (9.2) AND SUBSTITUTE THE FOLLOWING UNDER (9.2):

“Where the Contract is based on a stipulated sum or Guaranteed Maximum Price, the Contractor shall submit a schedule of values to the Owner’s Representative before the first Application for Payment, allocating the entire Contract Sum to the Various portions of the Work. The schedule of values shall be prepared in the form, and supported by the data to substantiate its accuracy, required by the Architect and Owner’s Representative. This schedule, unless objected to by the Architect and Owner’s Representative, shall be used as a basis for reviewing the Contractor’s Applications for Payment. Any changes to the schedule of values shall be submitted to the Architect and Owner’s Representative and supported by such data to substantiate its accuracy as the Architect and Owner’s Representative may require, and unless objected to by the Architect and Owner’s Representative, shall be used as a basis for reviewing the Contractor’s subsequent Applications for Payment.”

9.3 – Applications for Payments

IN THE FIRST SENTENCE OF (9.3.1), CHANGE "ten" TO "thirty”.

IN PARAGRAPH (9.3.1) IN THE FIRST AND SECOND SENTENCE DELETE THE WORD “Architect” AND SUBSTITUTE THE WORDS “Owner’s Representative”.

ADD THE FOLLOWING TO THE END OF PARAGRAPH (9.3.1):

“Payment requests shall consist of AIA Documents #702 "Application and Certificate for Payment"; AIA #703 "Continuation Sheet"; Contractors Affidavit of Payment to Subcontractors and Suppliers; Certified Payroll Form; EEO Documents; and Waivers of Lien. (Waivers of Lien are required from the general contractor in the full amount of the current payment application, and from all subcontractors, suppliers, or workers who provide more than \$10,000 of project material/labor of the Work. The waiver shall be in the amount(s) listed in the Contractor's Affidavit.) For final payment, the general contractor shall also provide a Waiver of Lien in the full amount of the contract price.

The Waiver of Lien and Contractor Affidavit forms used shall be the Peoria Park District's standard form(s): 1) "Final Waiver of Lien" (for general contractors), 2) "Waiver of Lien - General Contractor's Partial To Cover Only Certain Payments", 3) "Sub-Contractor's Final Waiver of Lien", 4)

"Waiver of Lien - Sub-Contractor's Partial To Cover Only Certain Payments, and 5) "Contractor's Affidavit". (These forms are included in the Project Manual, and are the required Waiver of Lien forms for the project.)

(If the Contractor is unable to provide the required sub-contractor waiver at the time the application for payment is submitted (preferred method) alternatively, it may be provided at the time that payment is delivered by the District. If the sub-contractor waiver(s) still cannot be provided at that time, the District will provide "two-party" checks in which the Contractor and the sub-contractor are named jointly as payees.)

Format of AIA #703 shall follow that of "Schedule of Values". All payment requests shall reflect retainage in the amount of 10% of completed work."

IN PARAGRAPH (9.3.1.1) DELETE THE WORDS "or by interim determination of the Architect, but not yet included in Change Orders".

ADD THE FOLLOWING SUB-PARAGRAPHS TO PARAGRAPH (9.3.1):

9.3.1.3 Upon Substantial Completion, the Owner will pay 95% percent of the amount due to the Contractor on account.

9.3.1.4 Monthly progress payments will be made by the Owner on projects lasting more than sixty days (from award of the bid to the Substantial Completion date given in the Supplementary Instructions to Bidders).

ADD THE FOLLOWING SUB-PARAGRAPHS TO PARAGRAPH (9.3.2):

9.3.2.1 Material stored on site will be considered for payment only when a Schedule of Stored Materials with appropriate values accompany the payment request as an attachment.

9.3.2.2 All material and work covered by partial payments made shall thereupon become the sole property of the Owner, but this provision shall not be construed as relieving the Contractor from the sole responsibility for the care and protection of material and work upon which payments have been made or the restoration of any damaged work, or as a waiver of the contract.

9.4 – Certificates for Payment

IN PARAGRAPH (9.4.1) DELETE THE WORDS "Architect" AND "Architect's" AND SUBSTITUTE THE WORDS "Owner's Representative" AND "Owner's Representative's".

IN PARAGRAPH (9.4.1) DELETE THE PHRASE "with a copy to the Contractor".

IN THE FIRST SENTENCE OF PARAGRAPH (9.4.2) DELETE THE WORD "Architect" AND SUBSTITUTE THE WORDS "Owner's Representative".

IN THE FIRST SENTENCE OF PARAGRAPH (9.4.2) AFTER THE WORDS "Architect's" ADD THE WORDS "and Owner's Representative's".

IN THE THIRD SENTENCE OF PARAGRAPH (9.4.2) DELETE THE WORDS "Architect has" AND SUBSTITUTE THE WORDS "Owner's Representative and Architect have".

9.5 – Decisions to Withhold Certification

IN PARAGRAPH (9.5.1) DELETE THE WORDS “Architect” AND “Architect’s” AND SUBSTITUTE THE WORDS “Owner’s Representative AND “Owner’s Representative’s”.

IN PARAGRAPH (9.5.2) DELETE THE WORD “Architect’s” AND SUBSTITUTE THE WORDS “Owner’s Representative’s”.

IN PARAGRAPH (9.5.4) DELETE THE WORD “Architect” AND SUBSTITUTE THE WORDS “Owner’s Representative”.

9.6 – Progress Payments

IN PARAGRAPHS (9.6.1), (9.6.3), AND (9.6.4) DELETE THE WORDS “Architect” AND SUBSTITUTE THE WORDS “Owner’s Representative”.

9.7 – Failure of Payment

IN PARAGRAPH (9.7) DELETE THE WORD “Architect” AND SUBSTITUTE THE WORDS “Owner’s Representative”.

IN PARAGRAPH (9.7) DELETE THE WORDS “or awarded by binding dispute resolution”.

9.8 – Substantial Completion

IN PARAGRAPH (9.8.2) DELETE THE WORD “Architect” AND SUBSTITUTE THE WORDS “Owner’s Representative”.

IN THE FIRST SENTENCE OF PARAGRAPH (9.8.3) DELETE THE WORD “Architect” AND SUBSTITUTE THE WORDS “Owner’s Representative assisted by the Architect”.

IN THE SECOND AND THIRD SENTENCES OF PARAGRAPH (9.8.3) DELETE THE WORDS “Architect’s” and “Architect” AND SUBSTITUTE THE WORDS “Owner’s Representative’s” and “Owner’s Representative”.

IN PARAGRAPH (9.8.4) DELETE THE WORD “Architect” AND SUBSTITUTE THE WORDS “Owner’s Representative”.

9.9 – Partial Occupancy or Use

IN PARAGRAPH (9.9.1) DELETE THE WORD “Architect” AND SUBSTITUTE THE WORDS “Owner’s Representative”.

9.10 – Final Completion and Final Payment

IN PARAGRAPH (9.10.1) IN THE FIRST AND SECOND SENTENCE AFTER THE FIRST TWO APPEARANCES OF THE WORD ‘Architect’ ADD THE WORDS “and Owner’s Representative”.

IN PARAGRAPH (9.10.1) DELETE THE THIRD AND FOURTH APPEARANCES OF THE WORD “Architect” and “Architect’s” AND SUBSTITUTE THE WORDS “Owner’s Representative” and “Owner’s Representative’s”.

IN PARAGRAPH (9.10.1) AFTER THE FIFTH APPEARANCE OF THE WORD “Architect’s” ADD THE WORDS “and Owner’s Representative’s”.

IN THE LAST SENTENCE OF PARAGRAPH (9.10.1) DELETE THE WORD “Architect’s” AND SUBSTITUTE THE WORDS “Owner’s Representative’s”.

IN PARAGRAPH (9.10.2) DELETE THE WORD “Architect” AND SUBSTITUTE THE WORD “Owner’s Representative”.

ADD THE FOLLOWING SUB-PARAGRAPH TO PARAGRAPH (9.10.2):

9.10.2.1 When all items including items noted within Division 10000 General Requirements are found to be complete and in conformance with the Contract Documents, a final payment will be issued.

IN PARAGRAPH (9.10.3) DELETE THE WORD “Architect” AND SUBSTITUTE THE WORDS “Owner’s Representative”.

ARTICLE 11: INSURANCE AND BONDS

11.1 – Contractor’s Insurance and Bonds

IN PARAGRAPH (11.1.1) IN THE FIRST SENTENCE DELETE THE WORDS “the Agreement or elsewhere in the Contract Documents” AND SUBSTITUTE THE FOLLOWING WORDS “Attachment A – Project Specific Insurance Requirements” (which is included in the last section of the Project Manual and the requirements therein shall be made part of the Contract Documents). In addition, if any of the work occurs within fifty feet of an active railroad line and the Contractor’s general liability coverages provide for exclusions of coverage when working on or near a railroad, the Contractor shall provide a separate Railroad Protective Liability Insurance Policy naming the railroad as the insured party, with the coverage limits required by that railroad.”

IN PARAGRAPH (11.1.1) IN THE LAST SENTENCE, DELETE THE WORDS “the Contract Documents” AND ADD THE WORDS “Attachment A”.

AT THE END OF PARAGRAPH (11.1.2) ADD THE FOLLOWING:

“The Contractor shall furnish a Performance Bond and a separate Labor and Material Payment Bond, each for one hundred percent (100%) of the Contract Sum. Form of these bonds shall be as provided by the Owner in the Project Manual and no other form will be accepted. The Surety shall be authorized to do business in the State of Illinois and be acceptable to the Owner.”

ADD THE FOLLOWING SUB-PARAGRAPHS TO PARAGRAPH (11.1)

11.1.5 The Contractor may, at his option, furnish Owner’s Protective Liability Insurance in lieu of naming the Owner Additional Insured on the Contractor’s policy, as required above. This insurance shall protect the Owner from claims as set forth in Paragraph 11.1.1 of the General Conditions, and to the limits required herein, as shown in “Attachment A”.

11.1.6 The Contractor shall furnish two copies of each of the required Certificates or Endorsements for each copy of the Agreement which shall specifically set forth evidence of all coverage required by the Contract Documents. The form of the Certificate(s) or Endorsement(s) shall be those as required in “Attachment A”. The Contractor shall also furnish to the Owner copies of any endorsements which limit coverage, or are subsequently issued amending coverage or limits of coverage.

11.2 – Owner’s Insurance

IN PARAGRAPH (11.2.1) DELETE THE FIRST AND SECOND SENTENCE.

ADD THE FOLLOWING TO PARAGRAPH (11.2.1) “If the work of the Project is being completed by one general or prime contractor rather than multiple prime contractors, the Contractor shall purchase and maintain property insurance upon the entire Work at the site to the full replacement value thereof. Such insurance shall be in a company or companies against which the Owner has no reasonable objection. This insurance shall include the interests of the Owner, the Contractor, Subcontractors and Sub-subcontractors in the Work.”

DELETE PARAGRAPHS (11.2.2) AND (11.2.3) IN THEIR ENTIRETY.

11.3 – Waiver of Subrogation

DELETE PARAGRAPHS (11.3.1) AND (11.3.2) IN THEIR ENTIRETY.

11.4 – Loss of Use, Business Interruption, and Delay in Completion Insurance

DELETE PARAGRAPH (11.4) IN ITS ENTIRETY:

11.5 – Adjustment and Settlement of Insured Loss

DELETE PARAGRAPHS (11.5.1) AND (11.5.2) IN THEIR ENTIRETY.

ARTICLE 12: UNCOVERING AND CORRECTION OF WORK

12.1 – Uncovering of Work

IN PARAGRAPH (12.1.1) DELETE THE WORD “Architect’s” AND SUBSTITUTE WORDS “Owner’s Representative’s and Architect’s”.

IN PARAGRAPH (12.1.1) DELETE THE WORD “Architect” AND SUBSTITUTE THE WORDS “Owner’s Representative”.

IN PARAGRAPH (12.1.2) AFTER THE WORD “Architect” ADD THE WORDS “and Owner’s Representative”.

12.2 – Correction of Work

IN PARAGRAPH (12.2.1) AFTER THE WORD “Architect” ADD THE WORDS “and Owner’s Representative”.

ARTICLE 13: MISCELLANEOUS PROVISIONS

13.4 – Tests and Inspections

IN PARAGRAPH (13.4.4) AFTER THE WORD “Architect” ADD THE WORDS “and Owner’s Representative”.

ARTICLE 14: TERMINATION OR SUSPENSION OF THE CONTRACT

14.1 – Termination by the Contractor

IN SUB-PARAGRAPH (14.1.1.3) DELETE THE WORD “Architect” AND SUBSTITUTE THE WORDS “Owner’s Representative”.

14.2 – Termination by the Owner for Cause

IN PARAGRAPH (14.2.2) DELETE THE PHRASE “, upon certification by the Architect that sufficient cause exists to justify such action,”.

IN PARAGRAPH (14.2.4) DELETE THE LAST SENTENCE AND ADD THE FOLLOWING “Upon application, the obligation for payment of the amount to be paid to the Contractor or Owner, as the case may be, shall survive termination of the Contract.”

14.4 – Termination by the Owner for Convenience

DELETE PARAGRAPH (14.4.3) IN ITS ENTIRETY AND SUBSTITUTE UNDER (14.4.3):

“In case of such termination for the Owner’s convenience, the Contractor shall be entitled to receive payment for Work executed, and costs incurred by reason of such termination. In no event, however, will such amounts exceed the Contract Sum reduced by the amount of prior payments except for increases pursuant to the claims procedure in the Contract Documents. Subcontracts, subsubcontracts, and purchase orders will contain appropriate provisions for termination for convenience under this Paragraph 14.4.”

ARTICLE 15: CLAIMS AND DISPUTES

15.1 – Claims

IN THE FIRST SENTENCE OF PARAGRAPH (15.1.2) DELETE “requirements of the binding dispute”.

IN PARAGRAPH (15.1.3.1) DELETE “Initial Decision Maker” AND SUBSTITUTE “Initial Recommendation Maker”

DELETE THE SECOND SENTENCE IN PARAGRAPH (15.1.3.2) IN ITS ENTIRETY.

DELETE PARAGRAPH (15.1.4.2) IN ITS ENTIRETY AND SUBSTITUTE THE FOLLOWING PARAGRAPH (15.1.4.2):

“The contract Sum and Contract Time may be adjusted in accordance with the Initial Recommendation Maker’s recommendation, subject to the right of either party to proceed in accordance with this Article 15. The Owner’s Representative will issue Certificates for Payment.”

DELETE (15.1.7) IN ITS ENTIRETY.

15.2 – Initial Decision

IN PARAGRAPH (15.2) DELETE IN THE HEADING “Initial Decision” AND SUBSTITUTE “Initial Recommendation”.

DELETE PARAGRAPH (15.2.1) IN ITS ENTIRETY AND SUBSTITUTE THE FOLLOWING PARAGRAPH (15.2.1):

“Claims, excluding those where the condition giving rise to the Claim is first discovered after expiration of the period for correction of the Work set forth in Section 12.2.2 or arising under Sections 10.3 10.4, and 11.5, shall be referred to the Initial Recommendation Maker for initial recommendation. The Architect

will serve as the Initial Recommendation Maker, unless otherwise indicated in the Agreement. Except for those Claims excluded by this Section 15.2.1, an initial recommendation shall be required as a condition precedent to mediation of any Claim. If an initial recommendation has not been rendered within 30 days after the Claim has been referred to the Initial Recommendation Maker, the party asserting the Claim may demand mediation without a decision having been rendered. “

DELETE PARAGRAPH (15.2.2) IN ITS ENTIRETY AND SUBSTITUTE THE FOLLOWING PARAGRAPH (15.2.2):

“The Initial Recommendation Maker will review Claims and within ten days of the receipt of a Claim take one or more of the following actions: (1) request additional supporting data from the claimant or a response with supporting data from the other party, (2) recommend rejecting the Claim in whole or in part, (3) recommend approving the Claim, (4) suggest a compromise, or (5) advise the parties that the Initial Recommendation Maker is unable to recommend a resolution of the Claim if the Initial Recommendation Maker lacks sufficient information to evaluate the merits of the Claim or if the Initial Recommendation Maker concludes that, in the Initial Recommendation Maker’s sole discretion, it would be inappropriate for the Initial Recommendation Maker to make recommendation on the Claim.”

IN PARAGRAPH (15.2.3) DELETE “Initial Decision Maker” AND SUBSTITUTE “Initial Recommendation Maker”.

IN PARAGRAPH (15.2.3) IN THE FIRST SENTENCE, DELETE “rendering a decision” AND SUBSTITUTE “rendering a recommendation”.

IN PARAGRAPH (15.2.4) DELETE “Initial Decision Maker” AND SUBSTITUTE “Initial Recommendation Maker”.

IN PARAGRAPH (15.2.4) DELETE THE LAST SENTENCE AND SUBSTITUTE THE FOLLOWING “Upon receipt of the response or supporting data, if any, the Initial Recommendation Maker will provide a recommendation regarding the Claim in accordance with Paragraph 15.2.2.”

DELETE PARAGRAPH (15.2.5) IN ITS ENTIRETY.

DELETE PARAGRAPH (15.2.6.1) IN ITS ENTIRETY.

15.3 – Mediation

IN PARAGRAPH (15.3.1) DELETE “as a condition precedent to binding dispute resolution”.

IN PARAGRAPH (15.3.2) DELETE THE THIRD SENTENCE IN ITS ENTIRETY AND SUBSTITUTE THE FOLLOWING SENTENCE “The request may be made concurrently with the filing of legal or equitable proceedings but, in such event, mediation shall proceed in advance of legal or equitable proceedings which shall be stayed pending mediation for a period of 60 days from the date of filing, unless stayed for a longer period by agreement of the parties or court order.”

IN PARAGRAPH (15.3.2) DELETE THE LAST SENTENCE IN ITS ENTIRETY.

DELETE PARAGRAPH (15.3.3) IN ITS ENTIRETY.

IN PARAGRAPH (15.3.4) DELETE THE FIRST SENTENCE IN ITS ENTIRETY.

15.4 – Arbitration

DELETE PARAGRAPHS (15.4.1), (15.4.1.1), (15.4.2), (15.4.3), (15.4.4.1), (15.4.4.2), AND (15.4.4.3) IN THEIR ENTIRETY.

ADD THE FOLLOWING ARTICLE 16: LABOR, SAFETY AND WAGE STANDARDS TO THE GENERAL CONDITIONS OF THE CONTRACT:

**ARTICLE 16
LABOR, WAGE, SAFETY, AND OTHER STANDARDS**

16.1 LABOR STANDARDS. All employers shall comply with the Employment of Illinois Workers on Public Works Act [30 ILCS 570/1 to 570/7].

16.2 WAGE STANDARDS.

16.2.1 PREVAILING WAGE ACT: Wages and benefits to employees shall comply with all Federal and State of Illinois statutes pertaining to public works projects and specifically: Wages of Employees on Public Works [820 ILCS 130/1 - 12].

16.2.2 Not less than the prevailing rate of wages plus benefits as determined by the Department of Labor shall be paid to all laborers, workers and mechanics performing work under this contract. All contractor's bonds shall include a provision as will guarantee the faithful performance of such prevailing wage clause as provided by this bid specification or contract.

16.2.3 The terms "general prevailing rate of hourly wages", "general prevailing rate of wages" or "prevailing rate of wages" when used in this Act mean the hourly cash wages plus fringe benefits for training and apprenticeship programs approved by the U.S. Department of Labor, Bureau of Apprenticeship and Training, health and welfare, insurance, vacations and pensions paid generally, in the locality in which the work is being performed, to employees engaged in work of a similar character on public works.

16.2.4 PREVAILING WAGE ACT/FOIA
Contractors and subcontractors shall submit proof to the Park District of certified payroll submission to the Illinois Department of Labor on a monthly basis in compliance with the Illinois Prevailing Wage Act. These records will be kept by the Park District for three years and may be reviewed by others through the Freedom of Information Act (FOIA). The Park District will exclude employee's address, telephone number, and social security number from public inspection.

16.3 SAFETY STANDARDS.

16.3.1 PROTECTION OF PERSONS AND PROPERTY: The Contractor and his subcontractors shall, at all times, comply with applicable provisions of Federal, State and Local laws.

16.3.1.1 The Contractor and his sub-contractors shall have written programs complying with Occupational Safety and Health Administration standards and/or Illinois Department of Labor requirements including, but not limited to the following: hazardous communications, hearing conservation, respirator use, confined space entry, scaffolding, ladders, ventilation, flammable and combustible liquids, and lockout/tagout. The Contractor shall submit documentation of their programs at the request of the Owner's Representative, or Occupational Safety and Health Administration and/or Illinois Department of Labor officials.

16.4 EQUAL EMPLOYMENT OPPORTUNITY/AFFIRMATIVE ACTION/SEXUAL HARASSMENT

16.4.1 During the performance of the contract, the contractor agrees to the following:

16.4.1.1 That it will not discriminate against any employee or applicant for employment because of race, color, religion, sex, marital status, national origin or ancestry, age, physical or mental handicap unrelated to ability, or an unfavorable discharge from military service; and further that it will examine all job classifications to determine if minority persons or women are under-utilized and will take appropriate affirmative action to rectify any such under-utilization.

16.4.1.2 That, if it hires additional employees in order to perform his contract or any portion thereof, it will determine the availability (in accordance with the Rules and Regulations of the Illinois Department of Human Rights) of minorities and women in the area(s) from which it may reasonably recruit and it will hire for each job classification for which employees are hired in such a way that minorities and women are not under-utilized.

16.4.1.3 That, in all solicitations or advertisements for employees placed by it or on its behalf, it will state that all applicants will be afforded equal opportunity without discrimination because of race, color, religion, sex, marital status, national origin or ancestry, age, physical or mental handicap unrelated to ability or an unfavorable discharge from military service.

16.4.1.4 That it will have a written sexual harassment policy to include at the minimum, the following:

16.4.1.4.1 a definition of sexual harassment under the law;

16.4.1.4.2 a description of sexual harassment utilizing examples;

16.4.1.4.3 a formalized complaint procedure;

16.4.1.4.4 a statement of victim's rights;

16.4.1.4.5 directions on how to contact the Illinois Department of Human Rights. Out-of-state companies must provide directions for filing with the enforcement agency within their state. Companies that issue a standard policy for all business locations must prepare an addendum providing directions on how to contact the appropriate enforcement agency; and

16.4.1.4.6 A recitation that there cannot be any retaliation against employees who elect to file charges.

16.4.1.4.7 In addition, it is recommended that the employer post a copy of the sexual harassment policy in a prominent and accessible location and distribute it in a manner to assure notice to all employees on an annual basis.

16.4.1.4.8 The Illinois Human Rights Act specifically provides that all documents may meet, but cannot exceed, the sixth-grade literacy level. Therefore, the employer's sexual harassment policy must be stated in plain language and in "laymen's terms".

- 16.4.1.5** That it will send to each labor organization or representative of workers with which it has or is bound by a collective bargaining or other agreement or understanding, a notice advising such labor organization or representative of the contractor's obligations under the Illinois Human Rights Act and the Department's Rules and Regulations. If any such labor organization or representative fails or refuses to cooperate with the contractor in its efforts to comply with such Act and Rules and Regulations, the contractor will promptly so notify the Department and the contracting agency and will recruit employees from other sources when necessary to fulfill its obligations thereunder.
- 16.4.1.6.** That it will submit reports as required by the Department's Rules and Regulations, furnish all relevant information as may from time to time be requested by the Department or the contracting agency, and in all respects comply with the Illinois Human Rights Act and the Department's Rules and Regulations.
- 16.4.1.7.** That it will permit access to all relevant books, records, accounts and work sites by personnel of the contracting agency and the Department for purposes of investigation to ascertain compliance with the Illinois Human Rights Act and the Department's Rules and Regulations.
- 16.4.1.8.** That it will include verbatim or by reference the provisions of this clause in every subcontract it awards under which any portion of the contract obligations are undertaken or assumed, so that such provisions will be binding upon such subcontractor. In the same manner as with other provisions of this contract, the contractor will be liable for compliance with applicable provisions of this clause by such subcontractors; and further it will promptly notify the contracting agency and the Department in the event any subcontractor fails or refuses to comply therewith. In addition, the contractor will not utilize any subcontractor declared by the Illinois Human Rights Commission to be ineligible for contracts or subcontracts with the State of Illinois or any of its political subdivisions or municipal corporations.

16.4.2 In the event of the contractor's non-compliance with the provisions of the Illinois Human Rights Act, the contractor may be declared ineligible for future contracts or subcontracts with the State of Illinois or any of its political subdivisions or municipal corporation, and the contract may be cancelled or voided in whole or in part, and such other sanctions or penalties may be imposed or remedies invoked as provided by statute or regulations.

END OF SUPPLEMENTARY GENERAL CONDITIONS

DIVISION 010000 GENERAL REQUIREMENTS

SECTION 010000 - GENERAL

A. SUMMARY OF THE WORK

1. The Work covered under this Contract consists of that work described by the Invitation to Bid, the Instructions/Supplemental Instructions to Bidders, the Bid/Proposal Form, the General/Supplemental Conditions of the Contract, these General Requirements, the Plans, and the Technical Specifications.
2. The Contractor shall be responsible for all items incidental to the scope of the Work intended by the bidding documents as per A.1 above, including but not limited to, expenses incurred by the requirements of various Sections of Division 010000, unless specifically stated otherwise herein.
3. Changes to the Work as required by approved Change Orders shall be at the expense of the Owner, however, requests for additional payments made after the fact will not be considered.

B. OCCUPANCY BY OWNER.

1. The Owner reserves the right to occupy any portion of the project before it has been entirely completed, with the understanding that such occupancy shall in no way constitute acceptance of the work, in whole or in part, or of any work performed under the Contract, provided that such occupancy does not substantially interfere with completion of the work by the Contractor.

SECTION 012100 – ALLOWANCES

A. GENERAL

1. This section includes administrative and procedural requirements governing allowances
 - a) Selected material and equipment are specified in the Contract Documents by allowances. In some cases, these allowances include installation. Allowances have been established in lieu of additional requirements and to defer selection of actual materials and equipment to a later date when additional information is available for evaluation. If necessary, additional requirements will be issued by Change Order.
 - b) Types of allowances may include the following:
 - 1) Lump-sum allowances.
 - 2) Unit-cost allowances.
 - 3) Inspection and testing allowances.

B. SELECTION AND PURCHASE

1. At the earliest practical date after award of the Contract, advise the Owner's Representative of the date when the final selection and purchase of each product or system described by an allowance must be completed to avoid delaying the Work.
2. At the Owner's Representative's request, obtain proposals for each allowance for use in making final selections. Include recommendations that are relevant to performing the Work.
3. Purchase products and systems selected by the Architect from the designated supplier.
4. Coordinate material and their installation for each allowance with related materials and installations to ensure that each allowance item is completely integrated and interfaced with related work.

C. SUBMITTALS

1. Submit proposals for purchase of products or systems included in allowances, in the form specified for Change Orders.
2. Submit invoices or delivery slips to show the actual quantities of materials delivered to the site for use in fulfillment of each allowance.

D. UNUSED MATERIALS

1. Return unused materials to the manufacturer or supplier for credit to the Owner, after installation has been completed and accepted.
 - a) When requested by the owner's Representative, prepare unused material for storage by Owner where it is not economically practical to return the material for credit. When directed by the Owner's Representative, deliver unused material to the Owner's storage space. Otherwise, disposal of the unused material is the Contractor's responsibility.

E. SCHEDULE OF ALLOWANCES

1. ALLOWANCE #1: None, unless so stated herein
2. ALLOWANCE #2: None, unless so stated herein

SECTION 012600 - CHANGE ORDERS

A. OWNER'S REPRESENTATIVE'S FIELD ORDERS

1. From time to time during progress of the Work the Owner's Representative may issue an "Owner's Representative's Field Order" which interprets the Contract Documents or orders minor changes in the Work without change in Contract Sum or Contract Time.
2. Should the Contractor consider that a change in Contract Sum or Contract Time is required he shall submit an itemized proposal to the Owner's Representative **immediately and before proceeding with the Work**. If the proposal is found to be satisfactory and in proper order, the Field Order will be superseded by a Change Order.

B. PROPOSAL REQUESTS

1. From time to time during the progress of work the Owner's Representative may issue a "Proposal Request" for an itemized quotation for changes to the Work which may result in a change to the Contract Sum or Contract Time. This document **is not a Change Order** and is not a direction to proceed with the changes described therein.

C. CHANGE ORDERS

1. Change Orders are written documents describing changes in the Work, in the Contract Sum, in the Contract Time of Completion, or any combination thereof. Change Orders must be signed by both the Owner and the Architect/Owner's Representative prior to proceeding with the Work subject to the Change Order. **REQUESTS FOR "EXTRA'S" OR OTHER ADDITIONAL PAYMENTS OVER AND ABOVE THE CURRENT CONTRACT SUM WILL NOT BE CONSIDERED WITHOUT THE PRIOR, WRITTEN APPROVAL OF BOTH THE OWNER AND THE OWNER'S REPRESENTATIVE.**
 - a) INITIATION. Change Orders may be initiated by a "Field Order" or "Proposal Request" per paragraphs "A" and "B" above. In addition, either the Contractor or Owner (or Owner's Representative) may initiate a Change Order through:
 - 1) Discovery of a discrepancy in the Contract Documents,
 - 2) Discovery of concealed conditions or,
 - 3) Discovery, during the course of the Work, of methods of accomplishing the Work in a better or more economical manner.
 - b) PROCESSING CHANGE ORDERS.
 - 1) Change Orders will be dated and will be numbered in sequence.
 - 2) The Change Order will describe the change or changes, or will refer to the Proposal Requests or Field Orders involved.
 - 3) The Owner's Representative will issue three copies of each Change Order to the Contractor.
 - 4) The Contractor promptly shall sign all three copies and return them to the Owner's Representative.
 - 5) The Owner and Owner's Representative will retain two signed copies in their files, and will forward one signed copy to the Contractor.
 - 6) Should the Contractor disagree with the stipulated change in Contract Sum or change in Contract Time of Completion, or both:
 - i) The Contractor promptly shall return all three of the Change Orders, unsigned by him, to the Owner's Representative with a letter signed by the Contractor stating the reason or reasons for the Contractor's disagreement.
 - ii) The Contractor's disagreement with the Change Order shall not in any way relieve the Contractor of his responsibility to proceed with the change as ordered and to seek settlement of the dispute under pertinent provisions of the Contract Documents.

SECTION 012900 – PAYMENT PROCEDURES

A. SCHEDULE OF VALUES

1. Prior to the start of construction, submit a proposed Schedule of Values to the Owner's Representative which shows a detailed breakdown of the agreed Contract Sum showing values allocated to each of the various parts of the Work, as specified herein and in other provisions of the Contract Documents.
 - a) The Schedule of Values is required to be compatible (in the same format) with the Application for Payment "Continuation Sheet", AIA G703.
2. If not requested to submit additional data or to modify the submitted Schedule of Values within ten (10) days of submittal, the initially submitted Schedule shall be deemed approved.

B. APPLICATIONS FOR PAYMENT

1. Progress payments will be made only if specifically called for in the Agreement. In all other cases, the Contractor may submit an Application for Payment (3 copies) upon Substantial Completion (95% of the Contract Sum), with the balance of the Contract Sum to be paid at Final Completion.
 - a) **Article 9 of the Supplementary General Conditions defines the documentation required for each payment request.**
 - b) Applications for payment shall be delivered to the Owner's Project Manager at:

Department of Planning, Design, and Construction
Peoria Park District
Bradley Park Equipment Service
1314 N. Park Road
Peoria, Illinois 61604

SECTION 013100 - PROJECT MEETINGS

A. PRECONSTRUCTION CONFERENCE

1. Conduct a preconstruction conference prior to the start of the Work, at the location of the Work. Provide attendance by the designated personnel of the Contractor, including Sub-contractor's and/or suppliers of major components of the Work, if requested by the Owner's Representative.
 - a) AGENDA. Discuss items of significance that could affect progress including such topics as:
 - 1) Tentative construction schedule.
 - 2) Critical Work sequencing.
 - 3) Designation of responsible personnel.
 - 4) Procedures for processing field decisions and Change Orders.
 - 5) Procedures for processing Applications for Payment.
 - 6) Distribution of Contract Documents.
 - 7) Submittal of Shop Drawings, Product Data and Samples.
 - 8) Preparation of record documents.
 - 9) Use of the premises.
 - 10) Office, Work and storage areas.
 - 11) Equipment deliveries and priorities.
 - 12) Safety procedures.
 - 13) First aid.
 - 14) Security.
 - 15) Housekeeping.
 - 16) Working hours.
 - 17) Permits and Permitting Agency Requirements

B. PROJECT MEETINGS

1. Project Meetings will be held per the schedule determined at the Preconstruction Conference, or as needed for proper coordination and administration of the project.
 - a) AGENDA
 - 1) Review and correct or approve minutes of the previous progress meeting.
 - 2) Review progress of the Work since last meeting, including status of submittals for approval.
 - 3) Identify problems which impede planned progress.
 - 4) Develop corrective measures and procedures to regain planned schedule.
 - 5) Complete other current business.

C. REPORTING

1. Distribute copies of the minutes of each meeting to each party present, and to other parties who should have been present, no later than three business days after each meeting.

SECTION 013300 - SUBMITTALS

- A. Requirements for shop drawings, samples, mock-ups, product data, etc., relative to specific elements or components of the work are called out in the various sections of the Technical Specifications.
 1. Submit items to allow for Owner's Representative's review and approval, potential re-submission if full approval is not given, ordering, delivery, fabrication time, etc., so as to allow the Work to proceed in a timely manner and in conformance with the project schedule.
- B. OTHER CONTRACTOR SUBMITTALS
 1. Unless otherwise modified the Contractor shall also submit:
 - a) A "bar chart" type proposed construction schedule, within ten days after award of the Bid.
 - b) Other submittals as required by other section of Division 010000.
- C. Submission of the required Bonds and Certificate of Insurance are to be made prior to the Owner's issuance of a Notice to Proceed.

SECTION 014000 – QUALITY/REGULATORY REQUIREMENTS

- A. GENERAL: Contractors shall comply with all laws, rules and regulations governing the work.
 1. When Contractor observes that contract documents are at variance with specified codes, notify Owner's Representative in writing immediately. Owner's Representative will issue all changes in accord with General Conditions.
 2. When Contractor performs any work knowing or having reason to know that the work is contrary to such laws, rules and regulations and fails to so notify the Owner's Representative, Contractor shall pay all costs arising therefrom. However, it will not be the Contractor's primary responsibility to make certain that the contract documents are in accord with such laws, rules and regulations.
- B. SAFETY:
 1. Comply with all federal, state, and local laws, rules and regulations governing the installation/construction of the work.
 2. Develop and utilize safety program and training for workmen and sub-contractor employees.
- C. TESTING
 1. TESTS AND INSPECTIONS REQUIRED
 - a) Provide all tests and inspections required by governmental agencies having jurisdiction, as required by provisions of the Contract Documents and/or as specifically required by sections of the Technical Specifications.
 2. PAYMENT FOR TESTING
 - a) Include within the Contract Sum an amount sufficient to cover all testing, re-testing, and inspections required by the Contract documents and/or the Technical Specifications. Additionally pay for all testing and inspections required by all governmental agencies having jurisdiction.
 - 1) The Owner will pay for any testing and inspecting specifically requested by the Owner's Representative which are over and above those described in Paragraph 1.a) above.
 - 2) When initial tests (over and above those defined by 1.a) above) requested by the Owner's Representative indicate non-compliance with the Contract Documents, costs of initial tests associated with that non-compliance will be deducted by the Owner from the Contract Sum, and subsequent retesting occasioned by the non-compliance shall be performed by the same testing laboratory and the costs thereof shall be paid by the Contractor.
 3. WAIVER OF INSPECTION AND/OR TESTS
 - a) Specified inspections and/or tests may be waived only by the specific written approval of the Owner's Representative, and **such waivers will be expected to result in credit to the Owner equal to normal cost of such inspection and/or test.**

SECTION 014200 - REFERENCE STANDARDS AND DEFINITIONS

- A. Copies of Standards: Each entity engaged in construction on the Project is required to be familiar with industry standards applicable to that entity's construction activity. Copies of applicable standards are not bound with the Contract Documents.
 1. Where copies of standards are needed for performance of a required construction activity the Contractor shall obtain copies directly from the publication source.
 2. Although copies of standards needed for enforcement of requirements may be included as part of required submittals the Architect reserves the right to require the Contractor to submit additional copies as necessary for enforcement of requirements.
- B. Abbreviations and Names: Trade association names and titles of general standards are frequently abbreviated. Where such acronyms or abbreviations are used in the Specifications or other Contract Documents they mean the recognized name of the trade association standards generating organization authority having jurisdiction or other entity applicable to the context of the text provision. Refer to the Encyclopedia of Associations, published by Gale Research Co. available in most libraries.
- C. Definitions: Architect, Owner's Representative, and Owner's Project Manager

1. **ARCHITECT:** The Architect shall be the person or entity designated by the Owner as the Owner's Representative and shall be identified as such in the Agreement Between Owner and Contractor, and is referred to throughout the Contract Documents as if singular in number and masculine in gender.
2. **OWNER'S REPRESENTATIVE:** The duties of the Owner's Representative as listed in the Project Manual, include but are not limited to, construction phase observation and technical administration services.
 - a) **LIMITS OF AUTHORITY:** The Owner's Representative shall be authorized to provide approvals and interpretations concerning the plans, specifications and progress of the Work as bid, but is not authorized to change the scope of the Work on behalf of the Owner.
3. **OWNER'S PROJECT MANAGER:** The Owner's Project Manager will represent, act on behalf of, and provide interface between the Owner and the Contractor in respect to contract administration and/or other matters which affect the scope of the Work.
 - a) Unless defined otherwise in the Project Manual, the Owner's Project Manager shall be a designated member of the Planning, Design, and Construction Division of the Peoria Park District.
 - b) The Owner's Project Manager will also be the Owner's Representative and will provide construction phase observation and technical administration services, if a consultant Architect has not been engaged to do so, by the Owner.

SECTION 015000 – TEMPORARY FACILITIES & CONTROLS

A. MOBILIZATION

1. Furnish all labor, tools, materials, equipment, and incidentals necessary for preparatory work.
2. Provide and establish personnel, equipment, supplies, materials, offices or buildings, and other facilities necessary to work on the project.
3. Demobilize all of the above and remove temporary facilities at the completion of the project.

B. BARRIERS, PROTECTION OF SITE AND PROPERTY

1. GENERAL

- a) Owner's improvements to remain, existing utilities, as well as adjacent site improvements shall be protected from damage by barriers, guards and coverings. Damaged work shall be replaced or repaired to condition prevailing at time of signing of contract, at no additional cost to Owner.
- b) Provide 6' high, continuous chain link or orange plastic (used materials acceptable) construction fence to prohibit unauthorized personnel or public entry from the site of the Work. (Substitutions may be considered; submit request in writing to the Owner's Representative.)
- c) Contractor shall provide, erect and maintain additional planking, fences, protective canopies, railings, shoring, lights, warning signs, etc., as needed for the protection of adjacent property and the public.

2. LANDSCAPE PROTECTION

- a) All live, healthy trees, shrubs, etc. on the site or on the street fronts of the site, not specified to be removed and not interfering with installation of new work required hereunder, shall be protected against injury from construction operations.
- b) All shade trees which are to remain and which are liable to damage during the building operations, shall be properly boxed and protected from damage during the course of construction work as directed by the Park District. **No site-related work shall occur until the required tree protection (fencing, boxing, etc.) has been installed and approved by the Owner or his representative.**
 - 1) **LIQUIDATED DAMAGES:** The Owner reserves the right to charge the Contractor for damage to existing trees, and to deduct the charges from the amounts due the Contractor, based on the following schedule:

aa) Broken limbs 1" or over in diameter:	\$50 per caliper inch of limb
bb) Trenching or grading within the tree dripline or 20' from the trunk, whichever is less, of trees 4" or over in caliper diameter:	\$100 per tree/per foot within dripline, or within 20' minimum if applicable
cc) Damage to tree trunks, including "barking", nicking, gouging, etc.	\$150 per caliper inch of tree, per each injury

3. BARRIERS/CONSTRUCTION FENCE MATERIALS

- a) 2" open mesh chain link fence, 72" high minimum, galvanized, with appropriately sized posts; gates where indicated.
- b) Alternate barrier fencing materials may be acceptable, however, no additional payments will be made on account of approval of alternate barrier/safety fencing materials.
- c) Materials may be new or used, if in serviceable condition.

4. WATCHMAN SERVICE

- a) The Owner will not be responsible for loss due to theft or other damage which is not covered under Property Insurance. The Contractor shall make such arrangements for watchman service as he considers necessary and he shall be responsible for all loss or damage of his property, equipment, material, etc., at the site, and he shall make good such damage or loss without any additional cost to the Owner.

5. EXISTING IMPROVEMENTS - PROTECTION

- a) The Contractor shall be entirely responsible for all injuries to water pipes, electric conduits or cables, drains, sewers, gas mains, poles, telephones and telegraph lines, streets, pavements, sidewalks, curbs, culverts, retaining walls, building walls, foundation walls, or other structures of any kind met with during the progress of the Work, and shall be liable for damages to public or private property resulting therefrom.

C. CONSTRUCTION ACCESS, ROADS, AND PARKING AREAS

1. CONTRACTOR'S USE OF PREMISES

- a) The Contractor shall require that all personnel who will enter upon the Owner's property certify their awareness of and familiarity with the requirements of this Section.

2. CONSTRUCTION ACCESS

- a) To avoid traffic conflict with vehicles of the Owner's employees and customers, and to avoid over-loading of streets and driveways elsewhere on the Owner's property, limit the access of trucks and equipment to the route shown (IF SHOWN) on the Drawings as "Access Route". If access route is not shown on the Drawings, coordinate construction access and routes with the Owner's Project Manager.
- b) Do not permit such vehicles to park on any street or other area of the Owner's property except in the area shown on the Drawings as "Contractor's Parking Area". If not shown on the drawings, the Contractor's Parking Area shall be as designated by the Owner's Project Manager.
- c) Provide adequate protection for curbs and sidewalks over which trucks and equipment pass to reach the job site.

3. SECURITY

- a) Restrict the access of all persons entering upon the Owner's property in connection with the Work to the Access Route and to the actual site of the Work.

D. TEMPORARY ENVIRONMENTAL CONTROLS

1. GENERAL

- a) Provide temporary environmental controls at the site of the Work to ensure that construction operations have no harmful effects on adjacent properties and on members of the public who may come in proximity to the Work, and/or the employees of the Owner who are engaged in regular daily tasks and operations and are unable to be relocated to another work site during construction operations.
- b) Owner reserves the right to stop the Work, at the Contractor's expense, until the Contractor provides necessary control measures for the conditions listed below; additionally, the Owner reserves the right to perform or have performed necessary control measures, should the Contractor refuse to do so at the time requested and to deduct the cost of those expenses from the amount due the Contractor.

2. DUST CONTROL

- a) Provide dust control materials to minimize dust from construction operations. Prevent air-borne dust from dispersing into the atmosphere.

3. WATER CONTROL

- a). Control surface water to prevent damage to the project, the site and adjoining properties.
 - 1) Control fill, grading, and ditching to direct surface drainage away from excavations, pits, tunnels, and other construction areas; direct drainage to proper runoff channels or storm drainage utilities.
- b) Provide, operate and maintain hydraulic equipment of adequate capacity to control surface water.
- c) Dispose of drainage water in a manner to prevent flooding, erosion silting, or runoff of silt or sediment or other damage to all portions of the site or to adjoining properties.

4. RODENT CONTROL

- a) Provide rodent control to prevent infestation of construction or storage areas.
 - 1) Use methods and materials which will not adversely affect conditions at the site or on adjoining properties.

5. DEBRIS CONTROL

- a) Maintain all areas free of extraneous debris, waste, and rubbish.

6. POLLUTION CONTROL

- a) Prevent contamination of soil, water or atmosphere by the discharge of noxious substances from construction operations.
- b) Provide equipment and personnel, perform emergency measures to contain all spillages, and to remove contaminated soils or liquids.
 - 1) Excavate and dispose of all contaminated earth off-site. Replace with suitable compacted fill and topsoil.
- c) Take special measures, as necessary, to prevent harmful substances from entering public waters, including lakes, streams, intermittent drainage channels, and storm or sanitary sewers.

7. EROSION CONTROL

- a) Plan and execute construction and earthwork in a manner to control surface drainage from cuts and fills, and from borrow and waste disposal areas, to prevent erosion and sedimentation.
 - 1) Schedule the Work to minimize the areas of bare soil exposed at one time, if possible.
 - 2) Provide temporary control measures such as berms, dikes, and drains to prevent runoff of silt or sediment from the site.
 - 3) Comply with Section 015713.

E. PROJECT IDENTIFICATION AND SIGNAGE

1. GENERAL

- a) Provide and install project identification sign, if located and/or called out on the Drawings.

2. SUBMITTALS

- a) Provide shop drawing(s) of proposed sign/sign installation to Owner's Representative for approval, prior to installation

3. INSTALLATION

- a) Provide project sign as detailed on Drawings
- b) If not detailed on Drawings provide project identification sign per the following minimum requirement:
 - 1) Content
 - aa) Name of project
 - bb) Name of Owner
 - cc) Name of Architect(s) and major consultants
 - dd) Names of Contractor and major subcontractors
 - ee) Allow additional 200 characters of text explaining the project
 - 2) Construction
 - aa) Size: 4' x 8'
 - bb) Materials: Min. 5/8" AC DFPA Exterior Plywood, with (2) 4" x 4" x 12' long pressure treated post supports
 - cc) Paint: paint front and back, seal edges, provide content as approved by Owner's Representative. Conform to recognized sign painting standards in selection of paint materials. Use only professional sign painter with three years minimum experience to apply sign graphics and lettering.
 - 3) Install sign in a manner consistent with length of time of construction operations. Remove sign and fill post holes at project completion.

F. FIELD OFFICES

1. TEMPORARY FACILITIES

Provide and pay for temporary (new, or used if in serviceable condition) facilities and controls needed for the Work, if called out on the Drawings, which may include, but are not necessarily limited to:

- a) Temporary utilities such as heat, water, electricity, and telephone;
- b) Field office for the Contractor's personnel (required if shown on the Drawings; otherwise at the Contractor's option and expense).
 - 1) Conform with requirements for Engineer's Field Office Type B, as defined in Article 646.04 of the Standard Specifications for Road and Bridge Construction - Illinois Department of Transportation.
- c) Sanitary facilities;
- d) Enclosures such as tarpaulins, barricades, and canopies;
- e) Temporary fencing of the construction site;
- f) Project sign.

- 2. Comply with Federal, State, and local codes and regulations.

- a) Maintain temporary facilities and controls in proper and safe condition throughout the progress of the work. The Contractor is responsible for conformance with all safety codes and regulations for all Work under his jurisdiction, including that of Sub-Contractors.
- 3. Locate temporary facilities as shown on the Drawings, or as approved by the Owner's Representative if not shown on the Drawings.

SECTION 015713 – EROSION & SEDIMENT CONTROL

A. RELATED DOCUMENTS

- 1. Drawings and general provisions of the Contract, including General and Supplementary Conditions and Division 1 Specification Sections, apply to this Section.

B. SUMMARY

- 1. This Section includes the following:
 - a) Site erosion and sediment control
 - b) Silt fencing
 - c) Ditch checks
 - d) Erosion control blankets
 - e) Culvert and inlet protection
 - f) Stabilized entrance
- 2. Related Sections include the following:
 - a) Division 31 – Earthwork.
 - b) Division 32 – Exterior Improvements.
- 3. Erosion and Sediment Control Statement: The Peoria Park District takes the issue of construction related erosion and sediment control extremely seriously. The Peoria Park District is a community leader in the conservation and protection of our area's natural resources. This project will be watched closely by both staff and citizens for compliance with erosion and sediment control regulations and specifications.

C. QUALITY ASSURANCE

- 1. Materials and methods of construction shall comply with the following standards:
 - a) Illinois Department of Transportation
 - b) City of Peoria

D. PRODUCTS

- 1. Silt Fencing
 - a) Fabric for silt fencing shall consist of woven or nonwoven filaments of polypropylene, polyester, or polyethylene. Fabric shall be resistant to degradation by ultraviolet light and heat exposure. Fabric shall be rot, insect, and mildew proof, and have a high resistance to tearing.
 - 1) Fabric shall comply with the following physical properties:

aa) Grab tensile strength (lb) – ASTM D4632	200 (min)
bb) Grab elongation @ break (%) – ASTM D4632	12
cc) Burst strength (psi) – ASTM D751	250 (min)
dd) Trapezoidal tear strength (lb) – ASTM D4533	75
ee) Width (ft)	3.5 (min)
ff) Weight (oz/sq. yd) – ASTM D3776	4.0
gg) Equivalent opening size	30 (nonwoven)
hh) (EOS) sieve no. – Corps of Engrs. CS-02215	50 (woven)
- 2. Ditch Checks
 - a) Ditch checks will consist of silt fencing with the addition of wire reinforcement.
 - b) Wire shall be 9 gauge.
 - c) Alternate: Straw bales may be used in lieu of silt fencing
- 3. Posts
 - a) Posts shall be standard “T” or “U” steel posts or wood with a minimum cross section of 3 square inches. Posts shall be a minimum of 60” in length. Posts shall be driven a minimum of 24” into the ground.
- 4. Erosion Control Blankets
 - a) Excelsior Blanket: Excelsior blanket shall consist of a machine produced mat of wood excelsior of 80% 6” or longer fiber length. The wood from which the excelsior blanket is cut shall be properly cured to achieve adequately curled and barbed fibers.
 - 1) The blanket shall be of consistent thickness, with the fiber evenly distributed over the entire area of the blanket. The excelsior blanket shall be covered on the top side with a 90-day biodegradable extruded plastic mesh netting having an approximate minimum opening of 16 x 16 mm (5/8 x 5/8 in.) to an approximate maximum opening of 50 x 25 mm (2 x 1 in.). The netting shall be substantially adhered to the excelsior blanket by a knitting process using biodegradable thread or by an applied degradable adhesive. The netting shall be substantially adhered to the excelsior by a knitting process using biodegradable thread. The netting shall be entwined with the excelsior blanket for maximum strength and ease of handling.
 - 2) The excelsior blanket shall comply with the following:

aa) Minimum width, ± 25 mm (1 in.)	600 mm (24 in.)
bb) Minimum mass ± 10%	0.34 kg/sm (0.63 lb/sq yd)
cc) Minimum length of roll, approximately	45 m (150 ft)
 - 3) The excelsior blanket shall be smolder resistant.
- 5. Culvert And Inlet Protection
 - a) Culvert protection shall consist of a ditch check immediately upstream of every culvert entrance. Ditch check shall be installed to protect culvert interior from sedimentation.
 - b) Inlet protection shall consist of purpose made devices by:
 - Dandy Products, Inc.
 - P. O. Box 1980
 - Westerville, Ohio 43086-1980
 - Phone: 1-800-591-2284

Fax: 740-881-2791
www.dandyproducts.com
dlc@dandyproducts.com

or

NILEX, Inc.
15171 E. Fremont Drive
Centennial, CO 80112
Phone: 1-800-537-4241
Fax: 303-766-1110
www.nilex.com
denver@nilex.com

- c) "Or Equal" substitutions may be made with prior approval of Owner's Representative.
- 6. Stabilized Entrance
 - a) Stabilized entrance shall consist of coarse aggregate laid over geotextile fabric.
 - b) Dimensions: 70' long by 14' wide.
 - c) Geotextile Fabric: as per requirements of "silt fencing".
 - d) Aggregate: IDOT Class CA-1, CA-2, cA-3, or CA-4.

E. EXECUTION

- 1. Site Erosion And Sediment Control
 - a) Contractor is responsible for fulfilling terms of City of Peoria Erosion Control Permit and all applicable portions of the "Erosion, Sediment, and Stormwater Control Ordinance of the City of Peoria".
 - b) Install control devices as shown on erosion control plan.
 - c) Install additional measures as needed to control erosion and sedimentation on the site.
- 2. Silt Fencing Installation
 - a) Install silt fencing according to details in plans. The silt fence shall be entrenched to a minimum depth of 8".
 - b) The silt fence shall be installed on the contour, with the ends extending up-slope.
 - c) Install silt fencing before commencing site clearing work.
- 3. Ditch Check Installation
 - a) Install ditch checks according to details in plans.
 - b) Install ditch checks at locations shown on plans.
 - c) Install additional ditch checks as needed to control erosion within drainage swales as site conditions and weather dictate.
 - d) Install ditch checks immediately after swales are graded.
- 4. Erosion Control Blankets Installation
 - a) Install erosion control blankets as needed to control erosion in drainage swales and at the direction of the Owner's Representative.
 - b) Anchor stakes shall be driven at a spacing of 2 feet on center.
- 5. Culvert And Inlet Protection Installation
 - a) Install culvert protection at upstream entrances to all culverts.
 - b) Install culvert protection to intercept waterborne silt and sediment and prevent it from entering culvert pipes.
 - c) Install immediately after culvert installation.
 - d) Install inlet protection according to manufacturer's written instructions at each inlet immediately after inlet construction.
- 6. Stabilized Construction Entrance Installation
 - a) Install stabilized construction entrance and other approved measures as necessary to limit tracking of soil on to all paved surfaces.
 - b) Comply with all City of Peoria codes limiting tracking of soil on to City streets.
- 7. Maintenance
 - a) Inspect silt fences after each rainfall. Repair fencing, failures, end runs, and erosion cuts immediately.
 - b) Remove soil from silt fencing after each rainfall.
 - c) Erosion control maintenance and repair shall be considered incidental to the contract.
 - d) Tracked soil and sediment shall be removed from all paved surfaces on a daily basis.
 - e) Replace or provide new erosion and sediment control measures as needed during construction to provide protection to site and surrounding property for the entire time of construction, or until project is complete.
- 8. Close-Out
 - a) Remove silt fencing and other erosion and sediment control devices after lawn or seeding has been established.
 - b) Soil deposits remaining in place after silt fence is no longer required shall be dressed to conform to existing grade, and seeded with appropriate seed material.

SECTION 016000 – PRODUCT REQUIREMENTS

A. MATERIALS AND EQUIPMENT

- 1. STANDARD SPECIFICATIONS
 - a) Reference herein to known standard specifications of governmental agencies or technical societies shall refer to the latest edition of such specifications, adopted and published at date of these Specifications.
- 2. MANUFACTURED ARTICLES
 - a) All manufactured articles, materials and equipment to be incorporated in the work shall be new (unless otherwise specified) and of the quality specified and shall be used, erected, installed, connected, cleaned and conditioned as directed by and in conformity with job conditions to produce the best results obtainable.
 - 1) Field measurements for all special products and materials which requires close tolerances or fitting into other items or components of the Work shall be taken on the job by the party furnishing the materials.
- 3. QUALITY ASSURANCE
 - a) Per the Supplementary Instructions to Bidders, the Bidder by submission of a signed bid form, agrees to install products and equipment by brand and model name or names specified in the Technical Specifications, Divisions 02-35. Substitutions are allowed only in conformance to the following:

- 1) Proprietary Specification Requirement: Where only a single product or manufacturer is named, provide the product indicated. No substitutions will be permitted.
 - 2) Semiproprietary Specification Requirement: Where two or more products or manufacturers are named, provide one of the products indicated. No substitutions will be permitted
 - aa) Where either of the two cases above prevail, and the named product is accompanied by "or approved equal" substitutions will be allowed only upon written approval of the Owner's Representative prior to submission of bids.
 - 3) Non-Proprietary Specification Requirement: When the Specifications lists products or manufacturers that are available and are accompanied by "or equal", the Contractor may propose any available product that complies with the Specifications' requirements; however, the Owner's Representative shall determine if the produced item complies with those requirements.
 - 4) Descriptive Specification Requirement: Where Specifications describe a product or assembly listing exact characteristics required, with or without use of a brand, trade, or model name, provide a product or assembly that provides the characteristics and otherwise complies with the Contract Documents.
 - 5) Performance Specification Requirement: Where Specifications require compliance with performance requirements, provide products or assembly that comply with these requirements and are recommended by the manufacturer for the application indicated.
 - 6) Compliance with Standards, Codes, and Regulations: Where the Specifications only require compliance with an imposed code, standard, or regulation, select a product that complies with the standard, code, or regulation specified.
- b) **VISUAL MATCHING AND SELECTION**. Where the Specifications require matching an established sample or call for "as selected", the Owner's Representative's decision will be final on whether a proposed product matches satisfactorily.

B. STORAGE AND PROTECTION

1. **GENERAL**

- a) Contractor shall provide and maintain:
 - 1) Storage for materials and equipment to be installed in Project.
 - 2) Protection and security for stored materials and equipment, on and off site.
 - 3) Protection of existing on-site elements to remain.
 - 4) Protection of adjacent properties improvements

2. **METHODS**

- a) Store off grade and cover with impervious material all moisture or water vulnerable materials.
- b) Store finished products and equipment in an enclosed building, on or off site.
- c) Maintain integrity of shipping cartons until ready for installation.
- d) Provide separate storage for combustible and non-combustible products.
- e) Follow storage recommendations of product and equipment manufacturers.
- f) Other methods shall be subject to Owner's prior written approval.

3. The Contractor shall maintain an emergency phone number where a contact person can be notified at any time, Sundays and holidays included, of an emergency condition due to the work which requires immediate repair or protection.

C. SUBSTITUTIONS

1. See "SECTION 016000 – A. MATERIALS AND EQUIPMENT" for requirements pertaining to substitution of specified materials, products, equipment, etc.
2. Contractor may propose substitute materials, products, equipment, etc., after award of the Bid; however, such proposals are expected to result in a cost savings to the Owner and/or higher quality Work at no additional cost to the Owner.

D. WARRANTIES AND BONDS

1. **GENERAL**

- a) This Section specifies general administrative and procedural requirements for warranties and bonds required by the Contract Documents, including manufacturer's standard warranties on products and special warranties.
- b) Warranties for the Work and products and installations of each Contractor shall be one (1) year unless specified otherwise in the individual Sections of Divisions 02 through 35.
- c) **Disclaimers and Limitations**:
 - 1) Manufacturer's disclaimers and limitations on product warranties do not relieve the Contractor of the warranty on the Work that incorporates the products, nor does it relieve suppliers, manufacturers, and Contractors required to countersign special warranties with the Contractor.
 - 2) The responsibility of the Contractor in respect to the required warranties shall not be relieved or limited in any way by the failure of installed components, equipment, materials, etc., due to naturally occurring and/or re-occurring conditions at the site or area of the Work including, but not limited to:
 - aa) ground and soil conditions, especially as related to frost heave;
 - bb) high wind velocities (except those exceeding velocities normally used for calculating wind loading at the site of the Work);
 - cc) rain and water damage (unless caused by winds exceeding normal design limits);
 - dd) ice/snow loading on structures
 - ee) and other naturally occurring or re-occurring site conditions
 - 3) The Contractor shall notify the Owner's Representative, prior to the award of the contract, of any part or component of the Work that is, in his opinion, not designed to accommodate the existing, naturally occurring, or re-occurring conditions of the site, and whether or not a change in the proposed methods of construction, types of equipment, etc., will affect the bid price.
 - aa) Should the proposed change in construction methods, equipment type, etc., result in additional expense, the Owner reserves the right to request proposals from the other bidders and to make award the contract based on the bid amount which includes the proposed change.

2. **WARRANTY REQUIREMENTS**

- a) **Related Damages and Losses**: When correcting warranted Work that has failed, remove and replace other Work that has been damaged as a result of such failure or that must be removed and replaced to provide access for correction of warranted Work.

- b) Reinstatement of Warranty: When Work covered by a warranty has failed and been corrected by replacement or rebuilding, reinstate the warranty by written endorsement. The reinstated warranty shall be equal to the original warranty with an equitable adjustment for depreciation.
 - c) Replacement cost: Upon determination that Work covered by a warranty has failed, replace or rebuild the Work to an acceptable condition complying with requirements of the Contract Documents. The Contractor is responsible for the cost of replacing or rebuilding defective Work regardless of whether the Owner has benefited from use of the Work through a portion of its anticipated useful service life.
 - d) Owner's Recourse: Written warranties made to the Owner are in addition to implied warranties, and shall not limit the duties, obligations, rights and remedies otherwise available under the law, nor shall warranty periods be interpreted as limitations on time in which the Owner can enforce such other duties, obligations, rights or remedies.
 - aa) Rejection of Warranties: The Owner reserves the rights to reject warranties and to limit selections to products with warranties not in conflict with requirements of the Contract Documents.
 - e) The Owner reserves the right to refuse to accept Work for the Project where a special warranty, certification, or similar commitment is required on such Work or part of the Work, until evidence is presented that entities required to countersign such commitments are willing to do so.
 - f) For specific warranty requirements related to landscape materials, refer to the applicable Section.
3. SUBMITTALS
- a) Submit written warranties to the Owner's Representative prior to the date certified for Substantial Completion. If the Owner's Representative's Certificate of Substantial Completion designates a commencement date for warranties other than the date of Substantial Completion for the Work, or a designated portion of the Work, submit written warranties upon request of the Owner's Representative.
 - 1) When a designated portion of the Work is completed and occupied or used by the Owner, by separate agreement with the Contractor during the construction period, submit properly executed warranties to the Owner's Representative within fifteen days of completion of that designated portion of the Work.
 - b) Form of Submittal: At Final Completion, compile two copies of each required warranty and bond properly executed by the Contractor, or by the Contractor, Subcontractor, supplier, or manufacturer. Organize the warranty documents into an orderly sequence based on the table of contents of the Project Manual.
 - c) Bind warranties and bonds in heavy-duty, commercial quality, durable 3-ring vinyl covered loose-leaf binders, thickness as necessary to accommodate contents, and sized to receive 8-1/2" by 11" paper.
 - d) Provide heavy paper dividers with celluloid covered tabs for each separate warranty. Mark the tab to identify the product or installation. Provide a typed description of the product or installation, including the name of the product, and the name, address and telephone number of the installer.
 - e) Identify each binder on the front and the spine with the typed or printed title "WARRANTIES AND BONDS", the project title or name, and the name of the Contractor.
 - f) When operating and maintenance manuals are required for warranted construction, provide additional copies of each required warranty, as necessary, for inclusion in each required manual.

SECTION 017300 – EXECUTION

A. GEOTECHNICAL DATA

1. If the Owner has caused borings or other subsurface investigations to be made, the data or report pursuant to these investigations will be included in the Project Manual, as an Appendix, and labeled as such.
2. The Owner and Owner's Representative do not guarantee the accuracy or validity of the data, nor do they assume any responsibility for the Contractor's interpretation of the data.
3. The Contractor's may, at his option, perform additional subsurface investigation, however, it shall be at the Contractor's sole expense.

B. FIELD ENGINEERING

Provide such field engineering services as are required for proper completion of the Work including, but not limited to:

1. Establishing and maintaining lines and levels
2. Structural design of shores, forms, and similar items provided by the Contractor as part of his means and methods of construction.
3. Verify layout information shown on the Drawings, in relation to the property survey and existing benchmarks and control points. Preserve permanent reference points during construction.

C. COORDINATION OF TRADES AND SUB-CONTRACTORS

1. The Contractor shall be responsible for the proper fitting of all work and for the coordination of the operation of all trades, sub-contractors, or materials and men engaged upon the work. He shall be prepared to guarantee to each of his subcontractors the dimensions which may be required for fitting of their work to all surrounding work and shall do, or cause his agents to do, all cutting, fitting, adjusting and patching necessary to make the several parts of the work come together properly and fit the work to receive, or be received by that of other contractors.
2. When two or more prime contracts are being executed at one time in such manner that the work on one contract may interfere with the work of another, the Owner's Representative shall decide which contractor shall cease work and which shall continue, or whether the work on both contracts may progress at the same time and in what manner.
 - a) The Contractor shall not cause any unnecessary hindrance or delay to any other contractors on the premises, and shall be responsible for all damages done to the work of other contractors caused by him or by his employees.

D. REFERENCE AND CONTROL POINTS PROVIDED BY OWNER

In addition to layout procedures provided by the Contractor for proper performance of the Contractor's responsibilities:

1. Locate and protect existing control points before starting work on the site.
2. Preserve permanent reference points during progress of the Work.
3. Do not change or relocate reference points or items of the Work without specific approval from the Owner's Representative.
4. Promptly advise the Owner's Representative when a reference point is lost or destroyed, or requires relocation because of other changes in the Work.
5. Upon direction of the Owner's Representative, require the field engineer to replace reference stakes or markers.
6. Locate such replacement according to the original survey control.

E. REFERENCE AND CONTROL POINTS PROVIDED BY THE CONTRACTOR

Project Manual-Front Vestibule Repair- Bradley Park Equipment Service Center

1. If not provided by the Owner (and defined as the responsibility of the Owner in the Contract Documents) establish sufficient general reference points in the form of permanent bench marks, grade stakes or other markers as will enable the Contractor to proceed with the Work.
2. The Contractor may lay out his own work, or cause the Work to be laid out by a qualified party such as a Registered Land Surveyor or a Professional Engineer, as necessary.
3. The Contractor shall establish and be responsible for all lines, elevations and measurements of the structure utilities, installations, and other Work executed by him under the contract.
 - a) Exercise proper precautions to verify the figures and dimensions shown on the drawings before laying out the work; be responsible for any error resulting from failure to exercise such precaution.

SECTION 017329 - CUTTING AND PATCHING

A. CHASES AND OPENINGS

1. The Contractor is responsible for the provision and/or coordination of all chases, openings and recesses required by work of his own forces, subcontractors or separate contractors.
 - a) Each subcontractor or separate contractor shall be responsible for furnishing advance information to the General Contractor as to exact dimensions and locations of such chases and openings, and shall provide and set in place all necessary sleeves, inserts and forms.
 - b) Openings shall be accurately located, neatly cut, and no larger than necessary. Provide all rebuilding, patching, refinishing and painting required to restore the construction to original condition.
2. Provide shoring, bracing, and support as required to maintain structural integrity of the project.
3. Provide protection from cutting and patching operations as required for other portions of the project; protect the Work and existing improvements in proximity to the cutting and patching operations from the elements.

SECTION 017419 – CONSTRUCTION WASTE MANAGEMENT & DISPOSAL

A. PERIODIC CLEANING

1. Each Contractor shall clean up after his own work as needed and/or ensure that sub-contractors clean up after their work and remove accumulations of waste, debris, and rubbish caused by construction operations.
 - a) Remove all waste, rubbish and debris on a daily basis (if needed), as they accumulate, and after completion of the Work.

B. PROJECT COMPLETION

1. On completion of the project, the entire job shall be cleaned up and left in perfect condition, including adjacent areas.
 - a) Marred surfaces shall be patched or repaired and touched up to match adjoining surfaces.
 - b) All rubbish shall be removed from the site before acceptance.
 - c) New surfaces and/or exposed elements of the Work shall be protected from stain and marring. These surfaces shall be cleaned to the satisfaction of the Owner's Representative or replaced if said stains or mars are unable to be completely removed

C. GOVERNMENTAL REGULATIONS

1. Conduct cleaning and disposal operations in compliance with Federal, State and local ordinances and anti-pollution laws and regulations.

SECTION 017700 - PROJECT CLOSEOUT

A. GENERAL

Work includes:

1. Substantial Completion.
2. Final Completion
3. Closeout submittals.
4. Instruction

B. SUBSTANTIAL COMPLETION

1. Prepare and submit the list ("punch-list") required by the first sentence of Paragraph 9.8.2 of the General Conditions.
 - a) Within a reasonable time after receipt of the list the Owner's Representative will inspect to determine status of completion. Should the Owner's Representative determine that the Work is not Substantially Complete:
 - 1) The Owner's Representative will so notify the Contractor, in writing, giving the reasons therefore.
 - 2) Remedy the deficiencies and notify the Owner's Representative when ready for reinspection.
 - 3) The Owner's Representative will reinspect the Work.
 - b) When the Owner's Representative concurs that the Work is Substantially Complete:
 - 1) The Owner's Representative will prepare a "Certificate of Substantial Completion" on AIA form G704, accompanied by the Contractor's list of items to be completed or corrected, as verified and approved by the Owner's Representative.
 - 2) The Owner's Representative will submit the Certificate to the Owner and to the Contractor for their written acceptance of the responsibilities assigned to them in the Certificate.

C. FINAL COMPLETION

1. Prepare and submit the notice required by the first sentence of Paragraph 9.10.1 of the General Conditions.
 - a) Verify that the Work is complete including, but not necessarily limited to, the items mentioned in Paragraph 9.8.2 of the General Conditions. Certify that:
 - 1) the Contract Documents have been reviewed;
 - 2) the Work has been inspected for compliance with the Contract Documents;
 - 3) the Work has been completed in accordance with the Contract Documents;
 - 4) equipment and systems have been tested as required, and are operational;
 - 5) the Work is completed and ready for final inspection.
 - b) The Owner's Representative will make a final inspection to verify status of completion and if all "punch-list" items have been completed, and upon receipt of the Contractor's Final Application for Payment, issue a Certificate of Final Completion. Should the Owner's Representative determine that the Work is incomplete or defective:
 - 1) The Owner's Representative will so notify the Contractor, in writing, listing the incomplete or defective work.

- 2) Remedy the deficiencies promptly, and notify the Owner's Representative when ready for reinspection.
- c) FINAL APPLICATION FOR PAYMENT
 - 1) Submit a final Application for Payment to the Owner's Representative, showing all adjustments to the Contract Sum.
 - 2) If needed, the Owner's Representative will prepare a final Change Order showing adjustments to the Contract Sum which were not made previously by Change Orders.
 - 3) Include final waivers of lien from the Contractor, sub-contractors, and major suppliers.
 - 4) Final payment will not be released until all close-out submittals have been made, final cleaning has been performed, and required instruction(s) to Owner's personnel have been accomplished.

D. CLOSEOUT SUBMITTALS

- 1. When the Owner's Representative determines that the Work is acceptable under the Contract Documents, he will request the Contractor to make closeout submittals. Closeout submittals include, but are not necessarily limited to:
 - a) Project record documents described in "Section 017839".
 - b) Operation and maintenance manuals/data as described in "Section 017823".
 - c) Warranties and bonds as described in "Section 016000".
 - d) Keys and keying schedule;
 - e) Spare parts and materials extra stock;
 - f) Evidence of compliance with requirements of governmental agencies having jurisdiction including, but not necessarily limited to:
 - 1) Certificates of Inspection, as required
 - 2) Certificate(s) of Occupancy
 - g) Certificates of Insurance for products and completed operations;
 - h) Evidence of payment and release of liens.
 - 1) Consent of Surety to Final Payment
 - 2) Contractor's Final Waiver of Lien
 - 3) Separate releases or Waivers of Lien for sub-contractors, suppliers and others with lien rights against the Owner, together with a list of those parties.
 - i) List of subcontractors, service organizations, and principal vendors, including names, addresses, and telephone numbers where they can be reached for emergency service at all times including nights, weekends, and holidays.

SECTION 017823 - OPERATING/MAINTENANCE MANUALS & INSTRUCTION

A. GENERAL

- 1. Compile operating/product data and related information appropriate for Owner's maintenance and operation of products and equipment provided under the Contract.
- 2. Instruct Owner's personnel in operation and maintenance of products, equipment and systems.
- 3. OPERATIONS AND MAINTENANCE DATA REQUIRED:
 - a) Operating and maintenance manuals are required for each area of Work which is listed below, if that area of Work is included within the scope of Work of the project:
 - 1) HVAC
 - 2) Plumbing – including water supply, sewage and waste disposal
 - 3) Electrical
 - 4) Landscape irrigation system
 - 5) Fire sprinkler system
 - 6) Communications equipment and systems
 - 7) Materials and finishes

B. OPERATIONS/MAINTENANCE MANUALS - FORM OF SUBMITTAL

- 1. Prepare operating and maintenance manuals in the form of an instructional manual, utilizing heavy-duty, durable 3-ring vinyl covered loose-leaf binders, for use by the Owner's operating personnel. Organize into suitable sets of manageable size. Where possible, assemble instructions for similar equipment into a single binder. Provide when drawings or diagrams are required as part of the manual.
- 2. Provide sturdy manila or kraft envelope, accordion type file folder, or cardboard file boxes, properly labeled, of sufficient size to contain all submittals.
- 3. Submit one copy of data in final form at least fifteen days before final inspection. This copy will be returned within fifteen days after final inspection, with comments. After final inspection make corrections or modifications to comply with the Owner's Representative's comments and submit three copies of each approved manual to the Owner's Representative
- 4. WARRANTIES, BONDS AND SERVICE CONTRACTS
 - a) Provide a copy of each warranty, bond or service contract in the appropriate manual for the information of the Owner's operating personnel. Provide written data outlining procedures to be followed in the event of product failure. List circumstances and conditions that would affect validity of the warranty or bond. Provide list for each product containing name, address, and phone number of:
 - 1) Contractor.
 - 2) Subcontractor.
 - 3) Maintenance contractor, as appropriate.
 - 4) Local supply source for parts and replacement.
 - b) Identify area of responsibility of each contractor.

C. MANUAL FOR MATERIALS AND FINISHES

- 1. Submit two (2) copies of complete manual in final form.
- 2. Refer to individual Specification Sections for additional requirements on care and maintenance of materials and finishes.
- 3. Content for products, applied materials and finishes:
 - a) Manufacturer's data, giving full information on products.
 - 1) Catalog number, size, composition.
 - 2) Color and texture designations.

- 3) Information for re-ordering special-manufactured products.
 - 4. Instructions for care and maintenance.
 - a) Manufacturer's recommendations for types of cleaning agents and methods.
 - b) Cautions against cleaning agents and methods detrimental to product.
 - c) Recommended cleaning and maintenance schedule.
 - 5. Moisture-Protection and Weather-Exposed Products: Provide complete manufacturer's data with instructions on inspection, maintenance and repair of products exposed to the weather or designed for moisture-protection purposes.
 - 6. Manufacturer's Data: Provide manufacturer's data giving detailed information, including the following, as applicable:
 - a) Applicable standards.
 - b) Chemical composition.
 - c) Installation details.
 - d) Inspection procedures.
 - e) Maintenance information.
 - f) Repair procedures.
- D. INSTRUCTION
- 1. Instruct the Owner's personnel in proper operation and maintenance of systems, equipment, and similar items which were provided as part of the Work including, but not limited to;
 - a) Mechanical
 - b) Water supply
 - c) Electrical service/distribution and lighting
 - d) Other items or systems as required in individual sections of the Technical Specifications
 - 2. Instructions for the Owner's Personnel: For instruction of the Owner's operating and maintenance personnel, use experienced instructors thoroughly trained and experienced in the operation and maintenance of the equipment or system involved.

SECTION 017839 - PROJECT RECORD DOCUMENTS (AS-BUILTS)

- A. DOCUMENTS REQUIRED AT SITE
 - 1. The Contractor shall maintain at the job site one copy of all Drawings, Specifications, Addenda, approved Shop Drawings, Change Orders, and other Contract modifications.
 - a) Each of these project record documents shall be clearly marked "**Project Record Copy**"
 - b) Shall be maintained in good condition
 - c) shall be available at all times for inspection by the Park District, and shall not be used for construction purposes.
- B. Project-record drawings shall be marked up to show significant changes made during construction progress, referenced to visible and accessible features of the structures. Project-record drawings shall be kept current and no work shall be concealed until required information has been recorded.
- C. Record-documents shall be submitted in satisfactory condition to the Park District at the completion of the project. **FINAL COMPLETION OF THE PROJECT WILL NOT BE ATTAINED, AND FINAL PAYMENT WILL BE WITHHELD, UNTIL PROJECT "AS-BUILTS" ARE SUBMITTED TO AND APPROVED BY THE OWNER'S REPRESENTATIVE.**

END OF GENERAL REQUIREMENTS

PROJECT MANUAL FOR: **Peoria Park District**
Equipment Service Center - Vestibule Repairs

OWNER: Peoria Park District
1125 W. Lake Ave.
Peoria, IL 61614

DATE: 14 April 2026

Division	Section Title	Pages
DIVISION 01 - GENERAL REQUIREMENTS		69
011000	SUMMARY	
DIVISION 02 - EXISTING CONDITIONS		72
024119	SELECTIVE DEMOLITION	
DIVISION 06 - WOOD, PLASTICS & COMPOSITES		76
061300	HEAVY TIMBER CONSTRUCTION	
DIVISION 07 - THERMAL AND MOISTURE PROTECTION		79
079200	JOINT SEALANTS	
DIVISION 09 - FINISHES		85
099123	EXTERIOR PAINTING	
099300	STAINING AND TRANSPARENT FINISHING	88

SECTION 011000 - SUMMARY

PART 1 - GENERAL

1.1 SUMMARY

A. Section Includes:

1. Project information.
2. Work covered by Contract Documents.
3. Phased construction.
4. Work under separate contracts.
5. Access to site.
6. Coordination with occupants.
7. Work restrictions.
8. Specification and drawing conventions.
9. Miscellaneous provisions.

B. Related Requirements:

1. Section 015000 "Temporary Facilities and Controls" for limitations and procedures governing temporary use of Owner's facilities.

1.2 PROJECT INFORMATION

A. Project: Front Vestibule Repair Bradley Park ESC, #26-008

1. Project Location: Equipment Service Center, 1314 N. Park Rd., Peoria, IL. 61604

B. Owner: Peoria Park District, 1125 W. Lake Ave., Peoria, IL 61614.

1. Owner's Representative: Dave Voorhees, 309-678-0560.

1.3 WORK COVERED BY CONTRACT DOCUMENTS

A. The Work of Project is defined by the Contract Documents and consists of the following:

1. Project consists of vestibule glass removal and reinstallation, rough carpentry removal and full replacement with matching lumber type, sealants, minor painting, rough carpentry removal and miscellaneous repairs.
2. Project will be constructed under a single prime contract.

1.4 WORK UNDER SEPARATE CONTRACTS

A. General: Cooperate fully with separate contractors so work on those contracts may be carried out smoothly, without interfering with or delaying work under this Contract or other contracts. Coordinate the Work of this Contract with work performed under separate contracts.

1. No other work by others is known. N.A.

1.5 ACCESS TO SITE

A. General: Contractor shall have full use of Project site for construction operations during construction period. Contractor's use of Project site is limited only by Owner's right to perform work or to retain other contractors on portions of Project.

- B. Use of Site: Limit use of Project site to areas where work is indicated. Do not disturb portions of Project site beyond areas in which the Work is indicated. The building and adjacent parking lot and Entry-level areas will remain occupied and in use daily.
 - 1. Limits: Confine construction operations to project work limited. Connections of utilities may be required beyond project limited and shall be coordinated with Owner a minimum 72 hours in advance and require a written notice to proceed from the Owner.
 - 2. Driveways, Walkways and Entrances: Keep driveways and entrances serving premises clear and available to Owner, Owner's employees, and emergency vehicles at all times. Do not use these areas for parking or storage of materials, unless Owner's approves areas in writing.
 - a. Schedule deliveries to minimize use of driveways and entrances by construction operations.
 - b. Schedule deliveries to minimize space and time requirements for storage of materials and equipment on-site and or on roof.
- C. Condition of Existing Building: Maintain portions of existing building affected by construction operations in a weathertight and secure condition throughout construction period. Repair damage caused by construction operations, including damage to and walks.

1.6 WORK RESTRICTIONS

- A. Work Restrictions, General: Comply with restrictions on construction operations.
 - 1. Comply with limitations on use of public streets and with other requirements of authorities having jurisdiction.
- B. On-Site Work Hours: Limit work to normal business working hours of 6:30 a.m. to 3:30 p.m., Monday through Friday, unless otherwise indicated or on Peoria Park District holidays.
- C. Existing Utility Interruptions: Do not interrupt utilities serving facilities occupied by Owner or others unless permitted under the following conditions and then only after providing temporary utility services according to requirements indicated:
 - 1. Notify Owner not less than two days in advance of proposed utility interruptions.
 - 2. Obtain Owner's Representative's written permission before proceeding with utility interruptions.
- D. Noise, Vibration, and Odors: Coordinate operations that may result in high levels of noise and vibration, odors, or other disruption to Owner occupancy with Owner.
 - 1. Notify Owner not less than two days in advance of proposed disruptive operations.
 - 2. Obtain Owner's written permission before proceeding with disruptive operations.
- E. Nonsmoking Building: Smoking is not permitted within the property.
- F. Controlled Substances: Use of tobacco products and other controlled substances on Project site is not permitted.

1.7 SPECIFICATION AND DRAWING CONVENTIONS

- A. Specification Content: The Specifications use certain conventions for the style of language and the intended meaning of certain terms, words, and phrases when used in particular situations. These conventions are as follows:
1. Imperative mood and streamlined language are generally used in the Specifications. The words "shall," "shall be," or "shall comply with," depending on the context, are implied where a colon (:) is used within a sentence or phrase.
 2. Specification requirements are to be performed by Contractor unless specifically stated otherwise.
- B. Division 01 General Requirements: Requirements of Sections in Division 01 apply to the Work of all Sections in the Specifications.
- C. Drawing Coordination: Requirements for materials and products identified on Drawings are described in detail in the Specifications. One or more of the following are used on Drawings to identify materials and products:
1. Terminology: Materials and products are identified by the typical generic terms used in the individual Specifications Sections.
 2. Abbreviations: Materials and products are identified by abbreviations published as part of the U.S. National CAD Standard and scheduled on Drawings.
 3. Keynoting: Materials and products are identified by reference keynotes referencing Specification Section numbers found in this Project Manual.

PART 2 - PRODUCTS (Not Used)

PART 3 - EXECUTION (Not Used)

END OF SECTION 011000

SECTION 024119 - SELECTIVE STRUCTURE DEMOLITION

PART 1 - GENERAL

1.1 SUMMARY

- A. Section Includes:
 - 1. Demolition and removal of selected portions of building.
 - 2. Salvage of existing items to be reused.

1.2 DEFINITIONS

- A. Remove: Detach items from existing construction and legally dispose of them off-site unless indicated to be removed and salvaged or removed and reinstalled.
- B. Remove and Salvage: Carefully detach from existing construction, in a manner to prevent damage, and deliver to Owner ready for reuse.
- C. Remove and Reinstall: Detach items from existing construction, prepare for reuse, and reinstall where indicated.
- D. Existing to Remain: Existing items of construction that are not to be permanently removed and that are not otherwise indicated to be removed, removed and salvaged, or removed and reinstalled.

1.3 INFORMATIONAL SUBMITTALS

- A. Predemolition Photographs: At contractor's option, submit before Work begins.

1.4 FIELD CONDITIONS

- A. Owner will occupy all areas of the building immediately adjacent to selective demolition area. Conduct selective demolition so Owner's operations will not be disrupted.
- B. Conditions existing at time of inspection for bidding purpose will be maintained by Owner as far as practical.
- C. Notify Owner's Representative of discrepancies between existing conditions and Drawings before proceeding with selective demolition.
- D. Hazardous Materials: It is not expected that hazardous materials will be encountered in the Work.
 - 1. If suspected hazardous materials are encountered, do not disturb; immediately notify Owner's Representative.
- E. Storage or sale of removed items or materials on-site is not permitted.
- F. Utility Service: Maintain existing utilities indicated to remain in service and protect them against damage during selective demolition operations.

1. Maintain fire-protection facilities in service during selective demolition operations.

1.5 WARRANTY

- A. Existing Warranties: Remove, replace, patch, and repair materials and surfaces cut or damaged during selective demolition, by methods and with materials so as not to void existing warranties.

PART 2 - PRODUCTS

2.1 PERFORMANCE REQUIREMENTS

- A. Regulatory Requirements: Comply with governing EPA notification regulations before beginning selective demolition. Comply with hauling and disposal regulations of authorities having jurisdiction.
- B. Standards: Comply with ANSI/ASSE A10.6 and NFPA 241.

PART 3 - EXECUTION

3.1 EXAMINATION

- A. Survey existing conditions and correlate with requirements indicated to determine extent of selective demolition required.
- B. When unanticipated mechanical, electrical, or structural elements that conflict with intended function or design are encountered, investigate and measure the nature and extent of conflict. Promptly submit a written report to Owner's Representative.

3.2 UTILITY SERVICES AND MECHANICAL/ELECTRICAL SYSTEMS

- A. Existing Services/Systems to Remain: Maintain services/systems indicated to remain and protect them against damage.

3.3 PREPARATION

- A. Site Access and Temporary Controls: Conduct selective demolition and debris-removal operations to ensure minimum interference with roads, streets, walks, walkways, and other adjacent occupied and used facilities.
 1. Comply with requirements for access and protection specified in Division 01 Section "Temporary Facilities and Controls."
- B. Temporary Facilities: Provide ¾" temporary plywood infill panels at removed glass. Install plywood panels at the end of each day to keep the vestibule secured when work is not taking place. Store glass in a safe secure place while work is taking place.
- C. Temporary Shoring: Provide and maintain shoring, bracing, and structural supports as required to preserve stability and prevent movement, settlement, or collapse of construction and finishes to remain, and to prevent unexpected or uncontrolled movement or collapse of construction being demolished.

3.4 SELECTIVE DEMOLITION, GENERAL

- A. General: Demolish and remove existing construction only to the extent required by new construction and as indicated. Use methods required to complete the Work within limitations of governing regulations and as follows:
1. Neatly cut openings and holes plumb, square, and true to dimensions required. Use cutting methods least likely to damage construction to remain or adjoining construction. Use hand tools or small power tools designed for sawing or grinding, not hammering and chopping, to minimize disturbance of adjacent surfaces. Temporarily cover openings to remain.
 2. Cut or drill from the exposed or finished side into concealed surfaces to avoid marring existing finished surfaces.
 3. Do not use cutting torches until work area is cleared of flammable materials. At concealed spaces, such as duct and pipe interiors, verify condition and contents of hidden space before starting flame-cutting operations. Maintain fire watch and portable fire-suppression devices during flame-cutting operations.
 4. Locate selective demolition equipment and remove debris and materials so as not to impose excessive loads on supporting walls, floors, or framing.
 5. Dispose of demolished items and materials promptly. Comply with requirements in Division 01 Section "Construction Waste Management and Disposal."
- B. Removed and Salvaged Items:
1. Clean salvaged items.
 2. Pack or crate items after cleaning. Identify contents of containers.
 3. Store items in a secure area until delivery to Owner.
 4. Transport items to Owner's storage area on-site designated by Owner.
 5. Protect items from damage during transport and storage.
- C. Removed and Reinstalled Items:
1. Clean and repair items to functional condition adequate for intended reuse.
 2. Pack or crate items after cleaning and repairing. Identify contents of containers.
 3. Protect items from damage during transport and storage.
 4. Reinstall items in locations indicated. Comply with installation requirements for new materials and equipment. Provide connections, supports, and miscellaneous materials necessary to make item functional for use indicated.
- D. Existing Items to Remain: Protect construction indicated to remain against damage and soiling during selective demolition. When permitted by Owner's Representative, items may be removed to a suitable, protected storage location during selective demolition and cleaned and reinstalled in their original locations after selective demolition operations are complete.

3.5 DISPOSAL OF DEMOLISHED MATERIALS

- A. General: Except for items or materials indicated to be reused, salvaged, reinstalled, or otherwise indicated to remain Owner's property, remove demolished materials from Project site and legally dispose of them in an EPA-approved landfill.
 - 1. Do not allow demolished materials to accumulate on-site.
 - 2. Remove and transport debris in a manner that will prevent spillage on adjacent surfaces and areas.
 - 3. Remove debris from elevated portions of building by chute, hoist, or other device that will convey debris to grade level in a controlled descent.
- B. Burning: Do not burn demolished materials.
- C. Disposal: Transport demolished materials off Owner's property and legally dispose of them.

3.6 CLEANING

- A. Clean adjacent structures and improvements of dust, dirt, and debris caused by selective demolition operations. Return adjacent areas to condition existing before selective demolition operations began. Clean daily at the end of each day in any area outside the work area defined on the drawings.

END OF SECTION 024119

SECTION 061300 - HEAVY TIMBER CONSTRUCTION

PART 1 - GENERAL

1.1 SUMMARY

A. Section Includes:

1. Framing using timbers.

1.2 DEFINITIONS

- A. Timbers: Lumber of 5 inches nominal (114 mm actual) or greater in least dimension.
- B. Inspection agencies, and the abbreviations used to reference them, include the following:
1. NeLMA: Northeastern Lumber Manufacturers' Association.
 2. NLGA: National Lumber Grades Authority.
 3. WWPA: Western Wood Products Association.

1.3 INFORMATIONAL SUBMITTALS

- A. Certificates of Inspection: Issued by lumber-grading agency for exposed timber not marked with grade stamp.

1.4 DELIVERY, STORAGE, AND HANDLING

- A. Schedule delivery of materials to avoid extended on-site storage and to avoid delaying the Work.
- B. Store materials under cover and protected from weather and contact with damp or wet surfaces. Provide for air circulation within and around stacks and under temporary coverings.

PART 2 - PRODUCTS

2.1 TIMBER

- A. Comply with DOC PS 20 and with grading rules of lumber-grading agencies certified by ALSC's Board of Review as applicable.
1. Factory mark each item of timber with grade stamp of grading agency.
 2. For exposed timber indicated to receive a stained or natural finish, apply grade stamps to surfaces that are not exposed to

view, or omit grade stamps and provide certificates of grade compliance issued by grading agency.

- B. Timber Species and Grade: Alaska (yellow) cedar; **Select Structural** or **No. 1**, WCLIB.
- C. Moisture Content: Provide timber with 19 percent maximum moisture content at time of dressing.
- D. Dressing: Provide **dressed timber (S4S)** unless otherwise indicated.

2.2 TIMBER CONNECTORS

- A. **Re-use existing connecting steel plates**
- B. Provide new thru bolts, **3/4 inch (19 mm)** unless otherwise indicated (match existing diameter), complying with **ASTM A307, Grade A (ASTM F568M, Property Class 4.6)**; provide nuts complying with **ASTM A563 (ASTM A563M)**; and, where used previously, provide flat washers.
- C. Re-use existing shear plates,
- D. Materials: Unless otherwise indicated, fabricate from the following materials:
 - 1. Structural-steel shapes, plates, and flat bars complying with ASTM A36/A36M.
 - 2. Round steel bars complying with ASTM A575, Grade M 1020.
 - 3. Hot-rolled steel sheet complying with ASTM A1011/A1011M, Structural Steel, Type SS, Grade 33.
- E. Prepare existing steel connectors with rust-inhibitive primer, **2-mil (0.05-mm)** dry film thickness.
- F. Hot-dip galvanize steel assemblies and fasteners after fabrication to comply with ASTM A123/A123M or ASTM A153/A153M.

2.3 MISCELLANEOUS MATERIALS

- A. End Sealer: Manufacturer's standard, transparent, colorless wood sealer that is effective in retarding the transmission of moisture at cross-grain cuts and is compatible with indicated finish.
- B. Penetrating Sealer: Manufacturer's standard, transparent, penetrating wood sealer that is compatible with indicated finish.

2.4 FABRICATION

- A. Field fabricate members by cutting and restoring exposed surfaces to match specified surfacing. Finish exposed surfaces to remove planing or surfacing marks, and to provide a finish equivalent to that produced by machine sanding with No. 120 grit sandpaper.

- B. Coat crosscuts with end sealer.
- C. Seal Coat: After fabricating and surfacing each unit, apply a saturation coat of penetrating sealer on surfaces of each unit except for treated wood where the treatment included a water repellent.

PART 3 - EXECUTION

3.1 INSTALLATION

- A. General: Erect heavy timber framing true and plumb. Provide temporary bracing to maintain lines and levels until permanent supporting members are in place.
- B. Fitting: Fit members by cutting and restoring exposed surfaces to match specified surfacing.
 - 1. Predrill for fasteners using timber connectors as templates.
 - 2. Finish exposed surfaces to remove planing or surfacing marks, and to provide a finish equivalent to that produced by machine sanding with No. 120 grit sandpaper.
 - 3. Coat crosscuts with end sealer.
- C. Install timber connectors as indicated.
 - 1. Install bolts with orientation as indicated or, if not indicated, as directed by Owner Representative or match those that were removed during replacement of timber posts..

3.2 ADJUSTING

- A. Repair damaged surfaces and finishes after completing erection. Replace damaged heavy timber framing if repairs are not approved by Owner Representative.

END OF SECTION 061300

SECTION 079200 - JOINT SEALANTS

PART 1 - GENERAL

1.1 SUMMARY

- A. Section Includes:
 - 1. Nonstaining silicone joint sealants.
 - 2. Mildew-resistant joint sealants.
 - 3. Latex joint sealants.

1.2 ACTION SUBMITTALS

- A. Product Data: For each joint-sealant product.
- B. Samples: For each kind and color of joint sealant required.
- C. Joint-Sealant Schedule: Include the following information:
 - 1. Joint-sealant application, joint location, and designation.
 - 2. Joint-sealant manufacturer and product name.
 - 3. Joint-sealant formulation.
 - 4. Joint-sealant color.

1.3 INFORMATIONAL SUBMITTALS

- A. Product test reports.
- B. Preconstruction laboratory test reports.
- C. Preconstruction field-adhesion-test reports.
- D. Field-adhesion-test reports.
- E. Sample warranties.

1.4 QUALITY ASSURANCE

- A. Testing Agency Qualifications: Qualified according to ASTM C 1021 to conduct the testing indicated.

1.5 PRECONSTRUCTION TESTING

- A. Preconstruction Field-Adhesion Testing: Before installing sealants, field test their adhesion to Project joint substrates. Test joint sealants according to Method A, Field-Applied Sealant Joint Hand Pull Tab, in Appendix X1.1 in ASTM C 1193 or Method A, Tail Procedure, in ASTM C 1521.

1.6 WARRANTY

- A. Special Installer's Warranty: Installer agrees to repair or replace joint sealants that do not comply with performance and other requirements specified in this Section within specified warranty period.
 - 1. Warranty Period: Two years from date of Substantial Completion.
- B. Special Manufacturer's Warranty: Manufacturer agrees to furnish joint sealants to repair or replace those joint sealants that do not comply with performance and other requirements specified in this Section within specified warranty period.
 - 1. Warranty Period: Five years from date of Substantial Completion.

PART 2 - PRODUCTS

2.1 JOINT SEALANTS, GENERAL

- A. VOC Content of Interior Sealants: Sealants and sealant primers used inside the weatherproofing system shall comply with the following:
 - 1. Sealants and sealant primers for nonporous substrates shall have a VOC content of 775 g/L or less.
- B. Colors of Exposed Joint Sealants: As selected by Architect from manufacturer's full range.

2.2 NONSTAINING SILICONE JOINT SEALANTS

- A. Nonstaining Joint Sealants: No staining of substrates when tested according to ASTM C 1248.
- B. Silicone, Nonstaining, S, NS, 50, NT: Nonstaining, single-component, nonsag, plus 50 percent and minus 50 percent movement capability, nontraffic-use, neutral-curing silicone joint sealant; ASTM C 920, Type S, Grade NS, Class 50, Use NT.
 - 1. Products: Subject to compliance with requirements, available products that may be incorporated into the Work include, but are not limited to, the following:
 - a. Dow Corning Corporation; 795.
 - b. GE Construction Sealants; SilPruf NB.
 - c. May National Associates, Inc., a subsidiary of Sika Corporation U.S.; Bondaflex Sil 295 FPS NB.
 - d. Pecora Corporation; 895NST.
 - e. Tremco Incorporated; Spectrem 2.

2.3 MILDEW-RESISTANT JOINT SEALANTS

- A. Mildew-Resistant Joint Sealants: Formulated for prolonged exposure to humidity with fungicide to prevent mold and mildew growth.

- B. Silicone, Mildew Resistant, Acid Curing, S, NS, 25, NT: Mildew-resistant, single-component, nonsag, plus 25 percent and minus 25 percent movement capability, nontraffic-use, acid-curing silicone joint sealant; ASTM C 920, Type S, Grade NS, Class 25, Use NT.
 - 1. Products: Subject to compliance with requirements, available products that may be incorporated into the Work include, but are not limited to, the following:
 - a. Dow Corning Corporation; 786-M White.
 - b. GE Construction Sealants; SCS1700 Sanitary.
 - c. May National Associates, Inc., a subsidiary of Sika Corporation U.S.; Bondaflex Sil 100 WF.
 - d. Soudal USA; RTV GP.
 - e. Tremco Incorporated; Tremsil 200.

2.4 LATEX JOINT SEALANTS

- A. Acrylic Latex: Acrylic latex or siliconized acrylic latex, ASTM C 834, Type OP, Grade NF.
 - 1. Products: Subject to compliance with requirements, available products that may be incorporated into the Work include, but are not limited to, the following:
 - a. BASF Construction Chemicals, LLC, Building Systems; Sonolac.
 - b. May National Associates, Inc., a subsidiary of Sika Corporation U.S.; Bondaflex 600.
 - c. Pecora Corporation; AC-20.
 - d. Sherwin-Williams Company (The); [850A] [950A] [PowerHouse].
 - e. Tremco Incorporated; Tremflex 834.

2.5 JOINT-SEALANT BACKING

- A. Cylindrical Sealant Backings: ASTM C 1330, Type C (closed-cell material with a surface skin), as approved in writing by joint-sealant manufacturer for joint application indicated], and of size and density to control sealant depth and otherwise contribute to producing optimum sealant performance.
 - 1. Manufacturers: Subject to compliance with requirements, available manufacturers offering products that may be incorporated into the Work include, but are not limited to, the following:
 - a. BASF Construction Chemicals, LLC, Building Systems.
 - b. Construction Foam Products, a division of Nomaco, Inc.
- B. Bond-Breaker Tape: Polyethylene tape or other plastic tape recommended by sealant manufacturer.

2.6 MISCELLANEOUS MATERIALS

- A. Primer: Material recommended by joint-sealant manufacturer where required for adhesion of sealant to joint substrates indicated, as determined from preconstruction joint-sealant-substrate tests and field tests.

- B. Cleaners for Nonporous Surfaces: Chemical cleaners acceptable to manufacturers of sealants and sealant backing materials.
- C. Masking Tape: Nonstaining, nonabsorbent material compatible with joint sealants and surfaces adjacent to joints.

PART 3 - EXECUTION

3.1 PREPARATION

- A. Surface Cleaning of Joints: Clean out joints immediately before installing joint sealants to comply with joint-sealant manufacturer's written instructions and the following requirements:
 - 1. Remove laitance and form-release agents from concrete.
 - 2. Clean nonporous joint substrate surfaces with chemical cleaners or other means that do not stain, harm substrates, or leave residues capable of interfering with adhesion.
- B. Joint Priming: Prime joint substrates where recommended by joint-sealant manufacturer or as indicated by preconstruction joint-sealant-substrate tests or prior experience.
- C. Masking Tape: Use masking tape where required to prevent contact of sealant or primer with adjoining surfaces.

3.2 INSTALLATION OF JOINT SEALANTS

- A. General: Comply with ASTM C 1193 and joint-sealant manufacturer's written installation instructions for products and applications indicated, unless more stringent requirements apply.
- B. Install sealant backings of kind indicated to support sealants during application and at position required to produce cross-sectional shapes and depths of installed sealants relative to joint widths that allow optimum sealant movement capability.
- C. Install bond-breaker tape behind sealants where sealant backings are not used between sealants and backs of joints.
- D. Install sealants using proven techniques that comply with the following and at the same time backings are installed:
 - 1. Place sealants so they directly contact and fully wet joint substrates.
 - 2. Completely fill recesses in each joint configuration.
 - 3. Produce uniform, cross-sectional shapes and depths relative to joint widths that allow optimum sealant movement capability.
- E. Tooling of Nonsag Sealants: Immediately after sealant application and before skinning or curing begins, tool sealants to form smooth, uniform beads of configuration indicated. Use tooling agents that are approved in writing by sealant manufacturer and that do not discolor sealants or adjacent surfaces.

1. Provide concave joint profile per Figure 8A in ASTM C 1193 unless otherwise indicated.

3.3 FIELD QUALITY CONTROL

- A. Field-Adhesion Testing: Field test joint-sealant adhesion to joint substrates as follows:
 1. Extent of Testing: Test completed and cured sealant joints as follows:
 - a. Perform ten tests for the first 1000 feet of joint length for each kind of sealant and joint substrate.
 2. Test Method: Test joint sealants according to Method A, Field-Applied Sealant Joint Hand Pull Tab, in Appendix X1 in ASTM C 1193 or Method A, Tail Procedure, in ASTM C 1521.
- B. Evaluation of Field-Adhesion-Test Results: Sealants not evidencing adhesive failure from testing or noncompliance with other indicated requirements will be considered satisfactory. Remove sealants that fail to adhere to joint substrates during testing or to comply with other requirements. Retest failed applications until test results prove sealants comply with indicated requirements.

3.4 JOINT-SEALANT SCHEDULE

- A. Joint-Sealant Application: Exterior joints in horizontal traffic surfaces.
 1. Joint Locations:
 - a. Isolation and contraction joints in cast-in-place concrete slabs.
 - b. Tile control and expansion joints.
 - c. Joints between different materials listed above.
 - d. Other joints as indicated on Drawings.
 2. Joint Sealant: Silicone.
 3. Joint-Sealant Color: As selected by Architect from manufacturer's full range of colors.
- B. Joint-Sealant Application: Exterior joints in vertical surfaces and horizontal nontraffic surfaces.
 1. Joint Locations:
 - a. Construction joints in cast-in-place concrete.
 - b. Control and expansion joints in unit masonry.
 - c. Other joints as indicated on Drawings.
 2. Joint Sealant: Silicone, nonstaining, S, NS, 50, NT.
 3. Joint-Sealant Color: As selected by Architect from manufacturer's full range of colors.
- C. Joint-Sealant Application: Interior joints in horizontal traffic surfaces.
 1. Joint Locations:
 - a. Isolation joints in cast-in-place concrete slabs.
 - b. Control and expansion joints in tile flooring.
 - c. Other joints as indicated on Drawings.
 2. Joint Sealant: Silicone.

3. Joint-Sealant Color: As selected by Architect from manufacturer's full range of colors.
- D. Joint-Sealant Application: Interior joints in vertical surfaces and horizontal nontraffic surfaces.
1. Joint Locations:
 - a. Control and expansion joints on exposed interior surfaces of exterior walls.
 - b. Tile control and expansion joints.
 - c. Vertical joints on exposed surfaces of unit masonry walls and partitions.
 - d. Other joints as indicated on Drawings.
 2. Joint Sealant: Silicone.
 3. Joint-Sealant Color: As selected by Architect from manufacturer's full range of colors.
- E. Joint-Sealant Application: Interior joints in vertical surfaces and horizontal nontraffic surfaces not subject to significant movement.
1. Joint Locations:
 - a. Control joints on exposed interior surfaces of exterior walls.
 - b. Perimeter joints between interior wall surfaces and frames of interior doors and windows.
 - c. Other joints as indicated on Drawings.
 2. Joint Sealant: Acrylic latex.
 3. Joint-Sealant Color: As selected by Architect from manufacturer's full range of colors.
- F. Joint-Sealant Application: Mildew-resistant interior joints in vertical surfaces and horizontal nontraffic surfaces.
1. Joint Locations:
 - a. Joints between plumbing fixtures and adjoining walls, floors, and counters.
 - b. Tile control and expansion joints where indicated.
 - c. Other joints as indicated on Drawings.
 2. Joint Sealant: Silicone, mildew resistant, acid curing, S, NS, 25, NT.
 3. Joint-Sealant Color: As selected by Architect from manufacturer's full range of colors.
- G. Joint-Sealant Application: Concealed mastics.
1. Joint Locations:
 - a. Aluminum thresholds.
 - b. Sill plates.
 - c. Other joints as indicated on Drawings.
 2. Joint Sealant: Butyl-rubber based.
 3. Joint-Sealant Color: As selected by Architect from manufacturer's full range of colors.

END OF SECTION 079200

SECTION 099113 - EXTERIOR PAINTING

PART 1 - GENERAL

1.1 SUMMARY

- A. Section includes surface preparation and the application of paint systems on the following exterior substrates:
 - 1. Steel.

1.2 DEFINITIONS

- A. Gloss Level 1: Not more than 5 units at 60 degrees and 10 units at 85 degrees, according to ASTM D 523.
- B. Gloss Level 3: 10 to 25 units at 60 degrees and 10 to 35 units at 85 degrees, according to ASTM D 523.
- C. Gloss Level 4: 20 to 35 units at 60 degrees and not less than 35 units at 85 degrees, according to ASTM D 523.
- D. Gloss Level 5: 35 to 70 units at 60 degrees, according to ASTM D 523.
- E. Gloss Level 6: 70 to 85 units at 60 degrees, according to ASTM D 523.
- F. Gloss Level 7: More than 85 units at 60 degrees, according to ASTM D 523.

1.3 ACTION SUBMITTALS

- A. Product Data: For each type of product. Include preparation requirements and application instructions.
- B. Samples: For each type of paint system and each color and gloss of topcoat.
- C. Product List: For each product indicated. Include printout of current "MPI Approved Products List" for each product category specified, with the proposed product highlighted.

1.4 MAINTENANCE MATERIAL SUBMITTALS

- A. Furnish extra materials, from the same product run, that match products installed and that are packaged with protective covering for storage and identified with labels describing contents.
 - 1. Paint: Five percent, but not less than 1 gal. of each material and color applied.

PART 2 - PRODUCTS

2.1 PAINT, GENERAL

- A. MPI Standards: Provide products that comply with MPI standards indicated and that are listed in its "MPI Approved Products List."
- B. Material Compatibility:

1. Provide materials for use within each paint system that are compatible with one another and substrates indicated, under conditions of service and application as demonstrated by manufacturer, based on testing and field experience.
 2. For each coat in a paint system, provide products recommended in writing by manufacturers of topcoat for use in paint system and on substrate indicated.
- C. Colors: As selected by Owner's Representative from manufacturer's full range.
- 2.2 METAL PRIMERS
- A. Primer, Alkyd, Anti-Corrosive for Metal: MPI #79.
- 2.3 SOLVENT-BASED PAINTS
- A. Alkyd, Exterior Gloss (Gloss Level 6): MPI #9.
- PART 3 - EXECUTION
- 3.1 EXAMINATION
- A. Examine substrates and conditions, with Applicator present, for compliance with requirements for maximum moisture content and other conditions affecting performance of the Work.
 - B. Verify suitability of substrates, including surface conditions and compatibility with existing finishes and primers.
 - C. Proceed with coating application only after unsatisfactory conditions have been corrected.
 1. Application of coating indicates acceptance of surfaces and conditions.
- 3.2 PREPARATION
- A. Comply with manufacturer's written instructions and recommendations in "MPI Manual" applicable to substrates and paint systems indicated.
 - B. Clean substrates of substances that could impair bond of paints, including dust, dirt, oil, grease, and incompatible paints and encapsulants.
- 3.3 APPLICATION
- A. Apply paints according to manufacturer's written instructions and recommendations in "MPI Manual."
 - B. Apply paints to produce surface films without cloudiness, spotting, holidays, laps, brush marks, roller tracking, runs, sags, ropiness, or other surface imperfections. Cut in sharp lines and color breaks.
- 3.4 CLEANING AND PROTECTION
- A. Protect work of other trades against damage from paint application. Correct damage to work of other trades by cleaning, repairing, replacing,

and refinishing, as approved by Architect, and leave in an undamaged condition.

- B. At completion of construction activities of other trades, touch up and restore damaged or defaced painted surfaces.

3.5 EXTERIOR PAINTING SCHEDULE

A. Steel Substrates:

1. Alkyd System:

- a. Prime Coat: Primer, alkyd, anticorrosive for metal, MPI #79.
- b. Intermediate Coat: Exterior alkyd enamel matching topcoat.
- c. Topcoat: Alkyd, exterior, gloss (Gloss Level 6), MPI #9.

END OF SECTION 099113

SECTION 099300 - STAINING AND TRANSPARENT FINISHING

PART 1 - GENERAL

1.1 SUMMARY

- A. Section includes surface preparation and application of solid wood stain on the following substrates:

1. Exterior Substrates:
a. Wood-based panel products (trims, timbers and boards).

1.2 DEFINITIONS

- A. MPI Gloss Level 1: Not more than 5 units at 60 degrees and 10 units at 85 degrees, according to ASTM D523.
- B. MPI Gloss Level 4: 20 to 35 units at 60 degrees and not less than 35 units at 85 degrees, according to ASTM D523.
- C. MPI Gloss Level 5: 35 to 70 units at 60 degrees, according to ASTM D523.
- D. MPI Gloss Level 6: 70 to 85 units at 60 degrees, according to ASTM D523.
- E. MPI Gloss Level 7: More than 85 units at 60 degrees, according to ASTM D523.

1.3 ACTION SUBMITTALS

- A. Product Data: For each type of product. Include preparation requirements and application instructions.
1. Include printout of current "MPI Approved Products List" for each product category specified, with the proposed product highlighted.
- B. Samples: For each type of finish system and in each color and gloss of finish required.

1.4 MAINTENANCE MATERIAL SUBMITTALS

- A. Furnish extra materials, from the same product run, that match products installed and that are packaged with protective covering for storage and identified with labels describing contents.
1. Stain: Five percent, but not less than 1 gal. of each material and color applied.

1.5 QUALITY ASSURANCE

- A. Mockups: Apply mockups of each finish system indicated and each color selected to verify preliminary selections made under Sample submittals, to demonstrate aesthetic effects, and to set quality standards for materials and execution and verify that the existing coating is compatible with the new specified stain system.
1. Owner's Representative will select one surface to represent surfaces and conditions for application of each type of finish system and substrate.
 - a. Vertical and Horizontal Surfaces: Provide samples of at least **30 sq. ft. (9 sq. m).**
 - b. Other Items: Owner's Rep. will designate items or areas required.
 2. Final approval of stain color selections will be based on mockups. The mock up will also confirm the product specified and applied by the contractor is compatible with the existing coating.
 - a. If preliminary stain color selections are not approved, apply additional mockups of additional stain colors selected by Owner's Representative at no added cost to Owner.

1.6 Warranty

- A. Provide a one-year material and workmanship warranty. If any work is defective within that year, it should be redone / re-painted at no additional cost to the Owner. Warranty shall commence from date of Substantial Completion.

PART 2 - PRODUCTS

2.1 MANUFACTURERS

- A. Basis-of-Design Product: Subject to compliance with requirements, provide products indicated in wood finish systems schedules or comparable products by one of the following:
1. Sherwin Williams "Woodscapes" Premium Translucent Exterior Finish Stain or approved equivalent prior to bid date by Owner's Representative. Allow 72 hours for approval prior to bid time. Submit product info. to Owner's Rep. at dvoorhees@peoriaparks.org

2.2 MATERIALS, GENERAL

- A. MPI Standards: Products shall comply with MPI standards indicated and shall be listed in its "MPI Approved Products List." Front

B. Material Compatibility:

1. Materials for use within each paint system shall be compatible with one another and substrates indicated, under conditions of service and application as demonstrated by manufacturer, based on testing and field experience.
2. For each coat in a paint system, products shall be recommended in writing by manufacturers of topcoat for use in paint system and on substrate indicated.

C. Stain Colors: As selected by Owner's Representative from manufacturer's full range

PART 3 - EXECUTION

3.1 EXAMINATION

- A. Examine substrates and conditions, with Applicator present, for compliance with requirements for maximum moisture content and other conditions affecting performance of the Work.
- B. Maximum Moisture Content of Exterior Wood Substrates: 15 percent, when measured with an electronic moisture meter.
- C. Verify suitability of substrates, including surface conditions and compatibility with existing finishes and primers.
- D. Proceed with finish application only after unsatisfactory conditions have been corrected.
 1. Beginning finish application constitutes Contractor's acceptance of substrates and conditions.

3.2 PREPARATION

- A. Comply with manufacturer's written instructions and recommendations in "MPI Architectural Painting Specification Manual" applicable to substrates indicated.
- B. Remove hardware, covers, plates, and similar items already in place that are removable. If removal is impractical or impossible because of size or weight of item, provide surface-applied protection before surface preparation and finishing.
 1. After completing finishing operations, use workers skilled in the trades involved to reinstall items that were removed. Remove surface-applied protection if any.
- C. If any clean and prepare existing previously stained wood substrates of substances that could impair bond of stain, including existing loose paint/stain or scale, dust, dirt, oil, grease, and incompatible paints and encapsulants.

1. Any existing loose paint on existing wood shall be removed by hand tool methods and/or pressure washing method. If pressure washing method for wood is utilized it shall be done so of someone with previous experience pressure washing wood substrates and not to damage the existing wood by use of too much pressure. Maximum pressure for wood substrates shall be 1,400 PSI measured at 6". Protect all surrounding existing building elements from damage that may be caused by pressure washing. Ensure surface has dried thoroughly prior to application of new stain.
2. Remove dust, dirt, oil, and grease by washing with a detergent solution; rinse thoroughly with clean water and allow to dry. Remove grade stamps and pencil marks by sanding lightly. Remove loose wood fibers by brushing.
3. Remove mildew by scrubbing with a commercial wash formulated for mildew removal and as recommended by stain manufacturer.
4. After completing painting operations, use workers skilled in the trades involved to reinstall items that were removed. Remove surface-applied protection.

3.3 APPLICATION

- A. Apply finishes according to manufacturer's written instructions and recommendations in "MPI Architectural Painting Specification Manual."
- B. Apply finishes to produce surface films without cloudiness, holidays, lap marks, brush marks, runs, ropiness, or other surface imperfections.

3.4 CLEANING AND PROTECTION

- A. Protect work of other trades or adjacent existing surfaces such as aluminum, glass, steel louvers, and vents against damage from finish application. Correct damage by cleaning, repairing, replacing, and refinishing, as approved by Owner's Representative, and leave in an undamaged condition.
- B. At completion of construction activities of other trades, touch up and restore damaged or defaced finished wood surfaces.

3.5 EXTERIOR WOOD-FINISH-SYSTEM SCHEDULE

- A. Wood Substrates: Wood trim, panels, boards & timbers.
 1. Premium Translucent Finish, High Solids Stain System
MPI EXT 6.3K:
 - a. First Self Priming Coat: Stain, exterior, high solids Premium Translucent Finish, matching topcoat.
 - b. Second Topcoat: Stain, exterior, Translucent, MPI #16.
 - 1) Sherwin Williams; "Woodscapes Premium Translucent Stain".

Peoria Park District
Project No. 26-008

STAINING AND TRANSPARENT FINISHING
Section 099300

END OF SECTION 099300

**ATTACHMENT A –
INSURANCE REQUIREMENTS**

ATTACHMENT A.6
INSURANCE REQUIREMENTS
ROUTINE CONSTRUCTION, MAINTENANCE AND REPAIR PROJECTS

Contractor shall obtain insurance of the types and in the amounts listed below.

A. COMMERCIAL GENERAL AND UMBRELLA LIABILITY INSURANCE

Contractor shall maintain commercial general liability (CGL) and, if necessary, commercial umbrella insurance with a limit of not less than \$1,000,000 each occurrence. If such CGL insurance contains a general aggregate limit, it shall apply separately to this project/location.

CGL insurance shall be written on Insurance Services Office (ISO) occurrence form CG 00 01 10 93, or a substitute form providing equivalent coverage, and shall cover liability arising from premises, operations, independent contractors, products-completed operations, personal injury and advertising injury, and liability assumed under an insured contract (including the tort liability of another assumed in a business contract).

Owner shall be included as an insured under the CGL, using ISO additional insured endorsement CG 20 10 or a substitute providing equivalent coverage, and under the commercial umbrella, if any. This insurance shall apply as primary insurance with respect to any other insurance or self-insurance afforded to Owner.

There shall be no endorsement or modification of the CGL limiting the scope of coverage for liability arising from pollution, explosion, collapse, or underground property damage.

B. CONTINUING COMPLETED OPERATIONS LIABILITY INSURANCE

Contractor shall maintain commercial general liability (CGL) and, if necessary, commercial umbrella liability insurance with a limit of not less than \$1,000,000 each occurrence for at least one (1) year following substantial completion of the work.

Continuing CGL insurance shall be written on ISO occurrence form CG 00 01 10 93, or substitute form providing equivalent coverage, and shall, at minimum, cover liability arising from products-completed operations and liability assumed under an insured contract.

Continuing CGL insurance shall have a products-completed operations aggregate of at least two times its each occurrence limit.

Continuing commercial umbrella coverage, if any, shall include liability coverage for damage to the insured's completed work equivalent to that provided under ISO form CG 00 01.

C. BUSINESS AUTO AND UMBRELLA LIABILITY INSURANCE

Contractor shall maintain business auto liability and, if necessary, commercial umbrella liability insurance with a limit of not less than \$1,000,000 each accident. Such insurance shall cover liability arising out of any auto including owned, hired and non-owned autos.

Business auto insurance shall be written on Insurance Services Office (ISO) form CA 00 01, CA 00 05, CA 00 12, CA 00 20, or a substitute form providing equivalent liability coverage. If necessary, the policy shall be endorsed to provide contractual liability coverage equivalent to that provided in the 1990 and later editions of CA 00 01.

D. WORKERS COMPENSATION INSURANCE

Contractor shall maintain workers compensation as required by statute and employers liability insurance. The commercial umbrella and/or employers liability limits shall not be less than \$1,000,000 each accident for bodily injury by accident or \$1,000,000 each employee for bodily injury by disease.

If Owner has not been included as an insured under the CGL using ISO additional insured endorsement CG 20 10 under the Commercial General and Umbrella Liability Insurance required in this Contract, the Contractor waives all rights against Owner and its officers, officials, employees, volunteers and agents for recovery of damages arising out of or incident to the Contractor's work.

E. GENERAL INSURANCE PROVISIONS

- 1. Evidence of Insurance.** Prior to beginning work, Contractor shall furnish Owner with a certificate(s) of insurance and applicable policy endorsement(s), executed by a duly authorized representative of each insurer, showing compliance with the insurance requirements set forth above.

All certificates shall provide for 30 days written notice to Owner prior to the cancellation or material change of any insurance referred to therein. Written notice to Owner shall be by certified mail, return receipt requested.

Failure of Owner to demand such certificate, endorsement or other evidence of full compliance with these insurance requirements or failure of Owner to identify a deficiency from evidence that is provided shall not be construed as a waiver of Contractor's obligation to maintain such insurance.

Owner shall have the right, but not the obligation, of prohibiting Contractor or any subcontractor from entering the project site until such certificates or other evidence that insurance has been placed in complete compliance with these requirements is received and approved by Owner.

Failure to maintain the required insurance may result in termination of this Contract at Owner's option.

With respect to insurance maintained after final payment in compliance with a requirement above, an additional certificate(s) evidencing such coverage shall be promptly provided to Owner whenever requested.

Contractor shall provide certified copies of all insurance policies required above within 10 days of Owner's written request for said copies.

- 2. Acceptability of Insurers.** For insurance companies which obtain a rating from A.M. Best, that rating should be no less than A VII using the most recent edition of the A.M. Best's Key Rating Guide. If the Best's rating is less than A VII or a Best's rating is not obtained, the Owner has the right to reject insurance written by an insurer it deems unacceptable.
- 3. Cross-Liability Coverage.** If Contractor's liability policies do not contain the standard ISO separation of insureds provision, or a substantially similar clause, they shall be endorsed to provide cross-liability coverage.
- 4. Deductibles and Self-Insured Retentions.** Any deductibles or self-insured retentions must be declared to the Owner. At the option of the Owner, the Contractor may be asked to eliminate such deductibles or self insured retentions as respects the Owner, its officers, officials, employees, volunteers and agents or required to procure a bond guaranteeing payment of losses and other related costs including but not limited to investigations, claim administration and defense expenses.
- 5. Subcontractors.** Contractor shall cause each subcontractor employed by Contractor to purchase and maintain insurance of the type specified above. When requested by the Owner, Contractor shall furnish copies of certificates of insurance evidencing coverage for each subcontractor.

F. INDEMNIFICATION

To the fullest extent permitted by law, the Contractor shall indemnify and hold harmless the Owner and the Architect and their officers, officials, employees, volunteers and agents from and against all claims, damages, losses and expenses including but not limited legal fees (attorney's and paralegal's fees and court costs), arising

out of or resulting from the performance of the Contractor's work, provided that any such claim, damage, loss or expense (1) is attributable to bodily injury, sickness, disease or death, or injury to or destruction of tangible property, other than the work itself, including the loss of use resulting therefrom and (2) is caused in whole or in part by any wrongful or negligent act or omission of the Contractor, any Subcontractor, anyone directly or indirectly employed by any of them or anyone for whose acts any of them may be liable, except to the extent it is caused in part by a party indemnified hereunder. Such obligation shall not be construed to negate, abridge, or otherwise reduce any other right or obligation of indemnity which would otherwise exist as to any party or person described in this Paragraph. Contractor shall similarly protect, indemnify and hold and save harmless the Owner, its officers, officials, employees, volunteers and agents against and from any and all claims, costs, causes, actions and expenses including but not limited to legal fees, incurred by reason of Contractor's breach of any of its obligations under, or Contractor's default of, any provision of the Contract.

SAMPLE LIABILITY INSURANCE ENDORSEMENT

The following spaces preceded by an asterisk (*) need not be completed if this endorsement and policy have the same inception date.

ATTACHED TO AND FORMING PART OF POLICY NUMBER	*EFFECTIVE DATE OF ENDORSEMENT	*ISSUED TO
--	-----------------------------------	------------

This endorsement changes the policy. Please read it carefully.

AUTOMATIC ADDITIONAL INSUREDS

The following provision is added to (SECTION II), Who Is An Insured.

5. Any entity you are required in a written contract (hereinafter called Additional Insured) to name as an insured is an insured but only with respect to liability arising out of your premises, “your work” for the Additional Insured, or acts or omissions of the Additional Insured in connection with the general supervision of “your work” to the extent set forth below.
 - a. The Limits of Insurance provided on behalf of the Additional Insured are not greater than those required by such contract.
 - b. The coverage provided to the Additional Insured(s) is not greater than that customarily provided by the policy forms specified in and required by the contract.
 - c. All insuring agreements, exclusions and conditions of this policy apply.
 - d. In no event shall the coverages or Limits of Insurance in this Coverage Form be increased by such contract.

Except when required otherwise by contract, this insurance does not apply to:

- 1) “Bodily injury” or “property damage” occurring after
 - a) All work on the project (other than service, maintenance or repairs) to be performed by or on behalf of the Additional Insured(s) at the site of the covered operations has been completed; or
 - b) That portion of “your work” out of which the injury or damage arises has been put to its intended use by any person or organization other than another contractor or subcontractor engaged in performing operations for a principal as a part of the same project.
- 2) “Bodily injury” or “property damage” arising out of any act or omission of the Additional Insured(s) or any of their employees, other than the general supervision of work performed for the Additional Insured(s) by you.
- 3) “Property damage” to
 - a) Property owned, used or occupied by or rented to the Additional Insured(s);
 - b) Property in the care, custody or control of the Additional Insured(s) or over which the Additional Insured(s) is for any purpose exercising physical control; or

- c) “Your work” for the Additional Insured(s).

With respect to Additional Insureds who are architects, engineers or surveyors, this insurance does not apply “bodily injury”, “property damage”, “personal injury” or “advertising injury” arising out of the rendering of or the failure to render any professional services by or for you, including:

- a) The preparing, approving, or failing to prepare or approve maps, drawings, opinions, reports, surveys, change orders, designs or specifications; and
- b) Supervisory, inspection or engineering services.

Any coverages provided hereunder shall be excess over any other valid and collectible insurance available to the Additional Insured(s) whether primary, excess, contingent or on any other basis unless a contract specifically requires that this insurance be primary or you request that it apply on a primary basis.

No person or organization is an Additional Insured with respect to the conduct of any current or past partnership or joint venture that is not shown as a Named Insured in the Declarations.

END OF ATTACHMENT A.6

**ATTACHMENT B –
SOLICITATION AND HIRING FOR QUALIFYING CONSTRUCTION CONTRACTS & FORMS**

- QUALIFYING CONSTRUCTION CONTRACTS POLICY
- SUMMARY SHEET
- CERTIFICATE OF EQUAL EMPLOYMENT OPPORTUNITY COMPLIANCE FOR CONTRACTORS & VENDORS
- WORKFORCE PROFILE AND INSTRUCTIONS
- COMPANY OWNERSHIP CERTIFICATION
- MINORITY/WOMEN OWNED CONTACT SHEET
- CONTRACTOR/SUBCONTRACTOR WORKFORCE PLAN
- APPENDIX A OF 44 ILL ADMIN CODE 750

SECTION III BUSINESS

5.00 SOLICITATION AND HIRING FOR QUALIFYING CONSTRUCTION CONTRACTS

.01 OBJECTIVE

The Peoria Park District Staff and Board believe that diversity and equity are central to our mission. Diversity of race, color, gender, disability, age, and culture in our employees and those we work with is important to fairly represent the same diversity in our community. The differing perspectives available from a diverse workforce are important to solving the complex problems of our community.

As one of the four pillars of the **Peoria Park District's 4-Pronged Approach to Equity** document, **Pillar #3** is to **Actively Promote and Encourage the Diversity, Equity and Inclusiveness of Peoria Park District funded Contractors and Suppliers.**

The Peoria Park District actively promotes and encourages maximum participation of minorities and women on Peoria Park District construction, procurement, and maintenance contracts to ensure that those we serve and those we work with look like the residents of our community.

This goal is established with the following objectives in mind:

- (A) To ensure that construction contracts are awarded and administered in a nondiscriminatory manner;
- (B) To meet the goals and requirements of the Illinois Human Rights Act ("Act") which requires that every party to a public contract and every eligible bidder shall refrain from unlawful discrimination and undertake affirmative action to assure equality of employment opportunity and eliminate the effects of past discrimination (775 ILCS 5/2-105(A)(1) and of the Illinois Administrative Code ("Code") which requires public contractors and subcontractors to determine if minority persons or women are underutilized in any job classification and, if such underutilization exists, to take appropriate affirmative action to rectify underutilization (44 Ill Admin Code 750.110 and 750.120);
- (C) To promote the District's use of Minority-Owned and Women-Owned Businesses by removing barriers and encouraging a level playing field on which such businesses can compete fairly for construction contracts;
- (D) To strive to increase capacity and participation of minority and women labor as well as Minority-Owned and Women-Owned Businesses for Peoria Park District construction projects; and
- (E) To ensure that goals for Minority-Owned and Women-Owned Businesses are narrowly tailored in accordance with applicable law.

The Park Board recognizes that it is required to comply with applicable bidding laws, federal and state constitutions, statutes, and rules and regulations, as well as any applicable local ordinances.

.02 DEFINITIONS

For the purpose of this Policy, the terms set forth below shall have the following definitions:

"Minority Person" shall mean a person who is a citizen or lawful permanent resident of the United States and who is any of the following: (a) American Indian or Alaska Native (a person having origins in any of the original peoples of North and South America, including Central America, and who maintains tribal affiliation or community attachment); (b) Asian (a person having origins in any of the original peoples of the Far East, Southeast Asia, or the Indian subcontinent, including, but not limited to, Cambodia, China, India, Japan, Korea, Malaysia, Pakistan, the Philippine Islands, Thailand, and Vietnam); (c) Black or African American (a person having origins in any of the black racial groups of Africa); (d) Hispanic or Latino (a person of Cuban, Mexican, Puerto Rican, South or Central American, or other Spanish culture or origin, regardless of race); and (e) Native Hawaiian or Other Pacific Islander (a person having origins in any of the original peoples of Hawaii, Guam, Samoa, or other Pacific Islands).

"Woman" shall mean a person who is a citizen or lawful permanent resident of the United States and who is of the female gender.

"Minority-Owned Business" means a business which is at least 51% owned by one or more minority persons, or in the case of a corporation, at least 51% of the stock in which is owned by one or more minority persons; and the management and daily operations of which are controlled by one or more of the minority individuals who own it.

"Women-Owned Business" means a business which is at least 51% owned by one or more women, or in the case of a corporation, at least 51% of the stock in which is owned by one or more women; and the management and daily operations of which are controlled by one or more of the women who own it.

"Qualifying Construction Contract" or "Qualifying Construction Contracts" means any any or all construction projects with an estimated total base cost of \$50,000 or more.

"Responsible Bidder" means a person who has the capability in all respects to perform fully the contract requirements and who has the integrity and reliability that will assure good faith performance. Past performance may be considered as a part of this analysis. This further requires that the bidder is in compliance with the Act and Code.

"Responsive Bidder" means a person who has submitted a bid that conforms in all material respects to the invitation for bids.

"Subcontractor" includes any sub-subcontractors or any more remote contractors on the job.

Any definition above or herein that is not consistent with existing or subsequently added or amended provisions of the Act or Code shall be deemed modified to be consistent with the Act or Code. Any term used herein but not explicitly defined shall have the same meaning as in the Act or Code.

.03 PARTICIPATION GOALS AND AFFIRMATIVE STEPS

(A) Goals:

It is a goal of the Peoria Park District to ensure that the goals and provisions of the Act and Code are met and to encourage participation of minorities and women on Park District Qualifying Construction Projects.

Peoria Park District shall as permitted by law:

(1) endeavor to award not less than 20% of the total dollar amount of the Park District's Qualifying Construction Contracts to Minority-owned Businesses and not less than 5% of the total dollar amount of the Park District's Qualifying Construction Contracts to Women-owned Businesses ("Participation Goals"); and

(2) endeavor to ensure that a minimum of 20% of the total hours worked on any Qualifying Construction Contract are performed by Minority Persons and a minimum of 5% of the total hours worked are performed by Women ("Workforce Goals").

(B) Affirmative Steps:

Peoria Park District shall take the following affirmative steps to ensure that the aforesaid goals are met in respect to Qualifying Construction Projects:

1) Require that all contractors and subcontractors, as a part of their bid submission documents, provide information demonstrating that the contractor or subcontractor has examined all of its job classifications to determine if minority persons or women are underutilized in any classification, and if so, what affirmative action was taken to rectify that underutilization. (44 Ill Admin Code 750.110 (b) and 750.120);

2) Require that if a contractor or subcontractor hires additional employees in order to perform the contract or portion of the contract, it will determine the availability of minorities and women in the areas from which it might reasonably recruit and will hire for each job classification in a way that minorities and women are not underutilized (44 Ill Admin Code 750.110(c) and 120);

3) Include as a part of all contracts, and require as a part of all subcontracts, the Equal Opportunity Clause set forth in Appendix A of 44 Ill Admin Code 750;

4) Place qualified Minority-Owned and Women-Owned Businesses on solicitation lists;

5) Require that Minority-Owned and Women-Owned Businesses are solicited whenever they are potential sources, at varying sizes of projects;

6) Include in all advertisements for bid (legal notice in the Peoria Journal Star), "Bidders are also advised that contract documents for this project include the non-discrimination, equal opportunity and affirmative action provisions in the Human Rights Act and rules and regulations of

the Department of Human Rights. The Peoria Park District is an EEO organization and encourages participation by minority and female-owned firms.”

- 7) Notify applicable plan rooms and diverse agencies which have specific outreach and contacts with local Minority-Owned Businesses or Women-Owned Businesses of current projects out for bid to encourage the broadest notification to Minority-Owned Businesses and Women-Owned Businesses;
- 8) Include in all bid documents, a current list of Minority-Owned and Women-Owned Businesses for general contractors to be able to contact;
- 9) Provide access to a website for free download ability of bid documents for all contractors, including Minority-Owned Businesses and Women-Owned Business;
- 10) When economically feasible and legally permissible, divide construction projects into smaller tasks or quantities to permit maximum participation by Minority-Owned and Women-Owned Businesses;
- 11) Establish project and delivery schedules, when feasible, that encourage participation by Minority-Owned and Women-Owned Businesses;
- 12) Provide the following documentation in staff recommendations to the Park Board: all contractors and agencies notified of the work, all contractors known to download the bid documents, all contractors that bid on the work, which contractors and subcontractors are minority or women owned; the racial, ethnic, and gender breakdown of the contractor and subcontractor workforce on the form provided by PPD; and whether the contractor or subcontractor has violated any law or ordinance, failed to follow any PPD policies, or breached any contract with the PPD in the past;
- 13) Track final statistics of Peoria Park District construction projects for Minority-Owned Businesses and Women-Owned Businesses and workforce participation numbers quarterly and annually;
- 14) Require the general contractor on Qualifying Construction Contracts, if subcontracts are to be let, to follow the Good Faith Effort requirements defined below.

Good Faith Effort is defined as follows:

A good faith effort means the contractor actively and aggressively sought participation by Minority-Owned and Women-Owned Businesses and/or employment of Minority Persons and Women and to meet all requirements of the Act and Code.

Evidence of good faith effort includes, as appropriate:

- Meeting the requirements of the Act and Code as set forth above on an ongoing basis
- Based on the trades and availability of contractors required to complete the project, a

minimum of three minority/women owned firms must be contacted. The Park District's list of minority/women owned firms will be included in all bid documents.

- The bidder shall negotiate in good faith with the potential minority/women owned firms by not imposing any conditions which are not similarly imposed on all other subcontractors and suppliers, or by denying benefits ordinarily conferred on subcontractors or suppliers for the type of work for which bids were solicited. Minority and women owned businesses must be notified at least 3 business days prior to bid opening to allow adequate time to review and provide bid.
- On all Qualifying Construction Contracts, the bidder must complete and include in the bid, the **Minority/Women Owned Contact Sheet** form. This form will include name of companies contacted, the time and date companies were contacted, the method by which the companies were contacted, the response by the companies contacted, the area of work the companies were contacted about, and bid amounts received from the companies along with other comments.
- The low bidder shall provide to the Park District upon request, copies of all correspondence including without limitation, faxes, letters, text messages, and emails sent to minority/women owned firms.
- Assisting interested Minority-owned and Women-owned Businesses in obtaining bonding, lines of credit and insurance;
- Seeking services from available minority and women community organizations, contractors' groups, business assistance offices and other organizations, as appropriate, to provide assistance in recruiting Minority owned and Women-owned Businesses;
- Providing payroll records or other evidence showing the percentage of Minority Persons and Women employees;
- If a Minority-owned or Women-owned Business is rejected, providing sound reasons for rejection;
- Assisting interested Minority-owned and Women-owned Businesses in obtaining necessary equipment, supplies or materials;
- Placing qualified Minority-Owned and Women-Owned Businesses on solicitation lists;
- Ensuring that Minority-Owned and Women-Owned Businesses are solicited whenever they are potential sources, at varying sizes of projects; and
- When economically feasible and legally permissible, dividing construction projects into smaller tasks or quantities to permit maximum participation by Minority-Owned and Women-Owned Businesses

- All other good faith efforts or evidence of due diligence to meet the Park District's Workforce Goals;

.04 CONTRACT BID DOCUMENTS AND AWARD

The Park District shall include within the bid documents for each Qualifying Construction Contract:

- (A) A copy of this policy (Section 5.00);
- (B) An identification of what documents are required to be submitted as a part of the bid under this policy;
- (C) Such documents as will assist in determining compliance with this policy (including without limitation, Company Ownership Form, EEO Form, Workforce Profile, Minority/Women Owned Contact Sheet, Contractor/Subcontractor Workforce Plan);
- (D) A requirement that the contractor meet the Park District's Workforce Goals or provide evidence of a good faith effort toward meeting the goals;
- (E) Appendix A of 44 Ill Admin Code 750;
- (F) Notice that all subcontracts must make reference to and incorporate the provisions of this policy. To the extent a subcontract does not reference and incorporate the provisions of this policy, the contractor will be deemed in breach of contract and in violation of this policy, and shall be subject to the provisions of Section .05. below; and
- (G) Such other documents as deemed appropriate.

Contracts will be awarded to the lowest Responsible and Responsive Bidder. Bids or proposals submitted without the required documentation identified in this policy are considered unresponsive and will be rejected.

.05 PROGRAM ADMINISTRATION

- (A) The Executive Director or designee shall administer and enforce the provisions of this policy;
- (B) The Park District Board, prior to voting on an applicable contract award, shall be provided information showing the bidder's compliance with this policy;
- (C) The Executive Director or designee shall monitor, track, and report contractors' compliance with this policy over the contract duration to ensure compliance with this policy, including prompt reporting of potential violations to the DEIA Committee and Park District Board. The Park District Board, after five (5) days' notice to the contractor and allowing the

contractor to make a presentation to the Park District Board, shall make a final determination of whether a violation has occurred and what penalty or remedy should be imposed for such violation. Potential penalties or remedies include, but are not limited to, termination of any contract or subcontract, corrective action steps, PPD's contractual remedies, or that the PPD will not consider that contractor to be a responsible bidder, in accordance with Section 8-1(c) of the Park District Code, 70 ILCS 1205/8-1(c), until that contractor provides evidence of making a good faith effort toward meeting these goals, or any combination of penalties and remedies that the Board deems appropriate. The decision of the Park Board is final. The Park Board shall promptly report its decision to the DEIA Committee.

- (D) The Executive Director or designee shall submit a quarterly report with statistics of Peoria Park District construction projects for Minority- Owned Businesses and Women-Owned Businesses and workforce participation numbers to DEIA Committee and to the Park Board for review; and
- (E) The Executive Director or designee shall submit an annual report to the DEIA Committee and Park Board of final statistics of Peoria Park District construction projects for Minority-Owned Businesses and Women-Owned Businesses and workforce participation numbers.

SUMMARY SHEET

SOLICITATION AND HIRING FOR QUALIFYING CONSTRUCTION CONTRACTS

(Construction Projects of \$50,000.00 or more)

1. Goals

Bidder must meet Park District's goals stated below or provide evidence of good faith effort toward meeting the goals to be considered a Responsible and Responsive Bidder.

- Not less than 20% of the total dollar amount of the Contract awarded to go to Minority-owned Businesses
- Not less than 5% of the total dollar amount of the Contract awarded to go to Women-owned Businesses
- Not less than 20% of total hours worked on the job to be by Minority Persons
- Not less than 5% of total hours worked on the job to be by Women

Prior to award, Bidder may be asked to attend a Park Board meeting to review goals and good faith efforts.

2. Required bid documents

The following forms are required with each bid submission. Failing to submit the forms may result in the bid being non-responsive.

- Bid Form
- Subcontractors List
- Certification of Compliance of Listed Provisions and Laws
- W-9
- Bid Bond
- Company Ownership Certification
- Certificate of Equal Employment Opportunity Compliance for Contractors and Vendors
- Workforce Profile
- Minority/Women Owned Contact Sheet
- Contractor/Subcontractor Workforce Plan

3. Required project administrative documents

- Signed Agreement Between Owner & Contractor
- Labor & Material Bond and Performance Bond
- Insurance
- Proof of Certified Payroll submitted to IDOL
- Lien Waivers
- Contractor Affidavit
- Contractor/Subcontractor Workforce Plan

4. Notice to Subcontractors

All subcontracts must make reference to and incorporate the provisions of this Qualifying Construction Contracts Policy. To the extent a subcontract does not reference and incorporate the provisions of the policy, the contractor will be deemed in breach of contract and in violation of this policy, and shall be subject to penalties or remedies stated below.

5. Violation & Penalties

During construction, not meeting self-stated goals listed on "Contractor/Subcontractor Workforce Plan" or "Minority/Women Owned Contact Sheet" shall appear to be a violation. This will result in the following:

- Staff will notify contractor and request additional information and corrective action steps

- Staff will give notice to the Diversity, Equity, Inclusion, & Accessibility (DEIA) Committee and the Park District Board
- The Park District Board, after 5 days' notice to the contractor and allowing the contractor to make a presentation to the Park District Board, shall make a final determination of whether a violation has occurred and what penalty or remedy should be imposed for such violations
- Potential penalties or remedies include:
 - Corrective action steps
 - Termination of any contract or subcontract
 - PPD's contractual remedies
 - PPD will not consider that contractor to be a responsible bidder on future projects until contractor provides evidence of making a good faith effort toward meeting these goals, or any combination of penalties and remedies that the Board deems appropriate.

The decision of the Park Board is final.



Peoria Park District

Certificate of Equal Employment Opportunity Compliance for Contractors & Vendors

The Peoria Park District is an Equal Opportunity Employer and it agrees with each of the provisions below and requires that all suppliers, contractors, subcontractors, and vendors doing business with the Park District be Certified Equal Employment Opportunity Employers in compliance with the Illinois Human Rights Act and such regulations promulgated thereunder, and, that any and all suppliers, contractors, subcontractors or vendors who are found to be in non-compliance with the Illinois Human Rights Act or said regulations may be declared ineligible for future contracts with this Park District; and, that each and every supplier, contractor, subcontractor or vendor does at all times in connection with any dealings with this Park District agree as follows:

- 1) That it will not discriminate against any employee or applicant for employment because of race, color, religion, sex, sexual orientation, marital status, order of protection status, national origin or ancestry, citizenship status, age, physical or mental disability unrelated to ability, military status or an unfavorable discharge from military service; and,

further, that it will examine all job classifications to determine if minority persons or women are underutilized and will take appropriate affirmative action to rectify any underutilization [44 Ill Admin Code 750.110(b)].

- 2) That, if it hires additional employees in order to perform this contract or any portion of this contract, it will determine the availability (in accordance with the Illinois Department of Human Rights Rules and Regulations) of minorities and women in the areas from which it may reasonably recruit and it will hire for each job classification for which employees are hired in a way that minorities and women are not underutilized.
- 3) That, in all solicitations or advertisements for employees placed by it or on its behalf, it will state that all applicants will be afforded equal opportunity without discrimination because of race, color, religion, sex, sexual orientation, marital status, order of protection status, national origin or ancestry, citizenship status, age, physical or mental disability unrelated to ability, military status or an unfavorable discharge from military service.
- 4) That it will send to each labor organization or representative of workers with which it has or is bound by a collective bargaining or other agreement or understanding, a notice advising the labor organization or representative of the contractor's obligations under the Illinois Human Rights Act and the Department's Rules and Regulations. If any labor organization or representative fails or refuses to cooperate with the contractor in its efforts to comply with such Act and Rules and Regulations, the contractor will promptly notify the Peoria Park District and will recruit employees from other sources when necessary to fulfill its obligations under the contract.
- 5) That it will submit reports as required by the Department's Rules and Regulations, furnish all relevant information as may from time to time be requested by the Department or the Peoria Park District, and in all respects comply with the Illinois Human Rights Act and the Department's Rules and Regulations.
- 6) That it will permit access to all relevant books, records, accounts and work sites by personnel of the Peoria Park District and the Department for purposes of investigation to ascertain compliance with the Illinois Human Rights Act and the Department's Rules and Regulations.
- 7) That it will include verbatim or by reference the provisions of this clause in every subcontract awarded under which any portion of the contract obligations are undertaken or assumed, so that the provisions will be binding upon the subcontractor. In the same manner as with other provisions of this contract, the contractor will be liable for compliance with applicable provisions of this clause by subcontractors; and further it will promptly notify the Peoria Park District and the Department in the event any subcontractor fails or refuses to comply with the provisions. In addition, the contractor will not utilize any subcontractor declared by the Illinois Human Rights Commission to be ineligible for contracts or subcontracts with the State of Illinois or any of its political subdivisions or municipal corporations.

Failure to properly complete and sign this form, certifying that the Company will agree to the above provisions of the Illinois Human Rights Act as well as the items below will result in it being returned unprocessed thereby resulting in a delay or denial of eligibility to be awarded work with the Peoria Park District.

The Company certifies that it has a written sexual harassment policy meeting the Illinois Human Rights Act and Illinois Department of Human Rights requirements.

Company Name

Company Address

Signature of Company Official

Name / Title

Telephone Number & Fax Number

Email Address

WORKFORCE PROFILE

IMPORTANT: Please complete the company workforce analysis below. Employment data must include ALL full-time company employees who were employed as of the most recent payroll period.

Job Classifications	Black Employees		White Employees		Hispanic Employees		Native American Employees		Asian Employees		Other Employees		TOTAL EMPLOYEES	
	M	F	M	F	M	F	M	F	M	F	M	F	M	F
1. Officials, Managers, Supervisors														
2. Professionals														
3. Technicians														
4. Sales														
5. Office/Clerical														
6. White Collar Trainees:														
7. Skilled Crafts:														
8. Apprentices:														
9. On-the-job Trainees:														
10. Semi-skilled														
11. Service Workers														
12. Unskilled														
TOTALS														

Company Name: _____

WORKFORCE PROFILE INSTRUCTIONS

RACE/ETHNIC IDENTIFICATION

WHITE (not of Hispanic origin): All persons having origins in any of the original peoples of Europe, North Africa, or the Middle East.

BLACK (not of Hispanic origin): All persons having origins in any of the Black racial groups of Africa.

HISPANIC: All persons of Mexican, Puerto Rican, Cuban, Central or South American, or other Spanish culture or origin, regardless of race.

ASIAN or PACIFIC ISLANDER: All persons having origins in any of the original peoples of the Far East, Southeast Asia, the Indian Subcontinent, or the Pacific Islands. This area includes, for example, China, India, Japan, Korea, the Philippine Islands, and Samoa.

NATIVE AMERICAN or ALASKAN NATIVE: All persons having origins in any of the original peoples of North America, and who maintain cultural identification through tribal affiliation or community recognition.

DESCRIPTION OF JOB CLASSIFICATIONS

OFFICIALS, MANAGERS, AND SUPERVISORS - Occupations requiring administrative personnel who set broad policies, and exercise over-all responsibility for the execution of these policies, and direct individual departments or special phases of a firm's operations. Includes: officials, executives, middle management, plant managers, department managers/superintendents, salaried foremen who are members of management, purchasing agents and buyers, and kindred workers.

PROFESSIONALS - Occupations requiring either college graduation or experience of such kind and amount as to provide a comparable background. Includes: accountants/auditors, airplane pilots and navigators, architects, artists, chemists, designers, dietitians, editors, engineers, lawyers, librarians, mathematicians, natural scientists, personnel and labor relations workers, physical scientists, physicians, social scientists, teachers, and kindred workers.

TECHNICIANS - Occupations requiring combination of basic scientific knowledge and manual skill which can be obtained through about 2 years of post high school education, such as is offered in many technical institutes and junior colleges, or through equivalent on-the-job training. Includes: drafters, engineering aids, junior engineers, scientific assistants, surveyors, technical illustrators, technicians (medical, dental, electronic physical sciences), and kindred workers.

SALES WORKERS - Occupations engaging wholly or primarily in direct selling. Includes: advertising agents/salespersons, insurance agents/brokers, real estate agents/brokers, stock and bond salespersons, demonstrators, salespersons and sales clerks, and kindred workers.

OFFICE AND CLERICAL WORKERS - Includes all clerical type work regardless of level of difficulty, where the activities are predominantly non-manual though some manual work not directly involved with altering or transporting the products is included. Includes: bookkeepers, cashiers, collectors (bills and accounts), messengers and office couriers, office machine operators, shipping and receiving clerks, stenographers, typist and secretaries, telegraph and telephone operators, and kindred workers.

WHITE COLLAR TRAINEES - Persons engaged in formal training for official, managerial, professional, technical, sales, office and clerical occupations.

SKILLED CRAFTS - Manual worker of relatively high skill level having a thorough and comprehensive knowledge of the processes involved in their work. Exercise considerable independent judgement and usually receive an extensive period of training. Includes: the building trades hourly paid foremen and leadmen who are not members of management, mechanics and repairmen, skilled machining occupations, compositors and typesetters, electricians, engravers, job setters (metal), motion picture projectionists, pattern and model makers, stationary engineers, tailors and tailoresses, and kindred workers.

APPRENTICES - Persons employed in a program including work training and related instruction to learn a trade or craft which is traditionally considered an apprenticeship, regardless of whether the program is registered with a Federal or State agency.

ON-THE-JOB TRAINEES - Persons engaged in formal training for craftsmen when not trained under apprentice programs; semi-skilled, unskilled and service occupations.

SEMI-SKILLED WORKERS - Workers who operate machine or processing equipment or perform other factory-type duties of intermediate skill level which can be mastered in a few weeks and require only limited training.

SERVICE WORKERS - Workers in both protective and non-protective service occupations. Includes: attendants (hospital and other institution, professional and personal service), barbers, charwomen and cleaners, cooks (except household), counter and fountain workers, elevator operators, fire fighters, guards, watchmen and doorkeepers, stewards, janitors, police officers and detectives, porters, waiters and waitresses, and kindred workers.

UNSKILLED WORKERS - Workers in manual occupations which generally require no special training. Perform elementary duties that may be learned in a few days and require the application of little or no independent judgement. Includes: garage laborers, car washers and greasers, gardeners (except farm) and groundskeepers, longshoremen and stevedores, lumbermen, craftsmen and wood choppers, laborers performing lifting, digging, mixing loading and pulling operations, and kindred workers.



PEORIA PARK DISTRICT

Company Ownership Certification

In compliance with Illinois Public Act 102-265, and Peoria Park District policy, disclosure of the information requested in this form is required by the Peoria Park District. Failure to properly complete and sign this form will result in it being returned unprocessed thereby resulting in a delay or denial of Company's eligibility to transact business with Peoria Park District.

Please answer all questions. Note, Company may answer "Yes" to more than one category.

- **Is the Company a Minority Owned Business?** YES NO

Check One:

Company holds Certification for this classification, or

Company is self-certifying

- **Is the Company a Woman Owned Business?** YES NO

Check One:

Company holds Certification for this classification, or

Company is self-certifying

- **Is the Company a Disability-Owned Business?** YES NO

Check One:

Company holds Certification for this classification, or

Company is self-certifying

- **Is the Company a Veteran Owned Business?** YES NO

Check One:

Company holds Certification for this classification, or

Company is self-certifying

- **Is the Company a Service Disabled Veteran Owned Business?** YES NO

Check One:

Company holds Certification for this classification, or

Company is self-certifying

Does Company qualify as a small business under federal Small Business Administration? YES NO

<https://www.sba.gov/document/support-table-size-standards>

Please list the name(s) of the Company majority owner(s): _____

Does Company have any parent and/or subsidiary companies? YES NO

If yes, please list all companies: _____

By signing this form, the Company and the individual signing below attest that the above questions have been answered truthfully, to the best of their knowledge.

Company Name

Company Address

Signature of Company Official

Name / Title

Telephone Number & Fax Number

Email Address



PEORIA PARK DISTRICT

Definitions for Company Ownership Certification

- Selected Classification of Owned Business means a business which is at least 51% owned by one or more persons of the selected ownership classification (i.e. minority, women, veteran, etc.), or in the case of a corporation, at least 51% of the stock in which is owned by one or more persons of the selected ownership classification; and the management and daily operations of which are controlled by one or more of the selected ownership classification individuals who own it.
- Control means the exclusive or ultimate and sole control of the business including, but not limited to, capital investment and all other financial matters, property, acquisitions, contract negotiations, legal matters, officer-director-employee selection and comprehensive hiring, operating responsibilities, cost-control matters, income and dividend matters, financial transactions and rights of other shareholders or joint partners. Control shall be real, substantial and continuing, no pro forma. Control shall include the power to direct or cause the direction of the management and policies of the business and to make the day-to-day as well as major decisions in matters of policy, management and operations. Control shall be exemplified by possessing the requisite knowledge and expertise to run the particular business and control shall not include simple majority or absentee ownership.
- Minority person shall mean a person who is a citizen or lawful permanent resident of the United States and who is any of the following:
 - a) American Indian or Alaska Native (a person having origins in any of the original peoples of North and South America, including Central America, and who maintains tribal affiliation or community attachment).
 - b) Asian (a person having origins in any of the original peoples of the Far East, Southeast Asia, or the Indian subcontinent, including, but not limited to, Cambodia, China, India, Japan, Korea, Malaysia, Pakistan, the Philippine Islands, Thailand, and Vietnam).
 - c) Black or African American (a person having origins in any of the black racial groups of Africa).
 - d) Hispanic or Latino (a person of Cuban, Mexican, Puerto Rican, South or Central American, or other Spanish culture or origin, regardless of race).
 - e) Native Hawaiian or Other Pacific Islander (a person having origins in any of the original peoples of Hawaii, Guam, Samoa, or other Pacific Islands).
- Woman shall mean a person who is a citizen or lawful permanent resident of the United States and who is of the female gender.
- Veteran means a person who (i) has been a member of the armed forces of the United States or, while a citizen of the United States, was a member of the armed forces of allies of the United States in time of hostilities with a foreign country and (ii) has served under one or more of the following conditions: (a) the veteran served a total of at least 6 months; (b) the veteran served for the duration of hostilities regardless of the length of the engagement; (c) the veteran was discharged on the basis of hardship; or (d) the veteran was released from active duty because of a service connected disability and was discharged under honorable conditions.
- Service-Disabled Veteran means a veteran who has been found to have 10% or more service-connected disability by the United States Department of Veterans Affairs or the United States Department of Defense.
- A Person with a Disability means a person who is a citizen or lawful resident of the United States and is a person qualifying as being disabled, meaning a person with a severe physical or mental disability that:
 - a) results from: amputation, arthritis, autism, blindness, burn injury, cancer, cerebral palsy, Crohn's disease, cystic fibrosis, deafness, head injury, heart disease, hemiplegia, hemophilia, respiratory or pulmonary dysfunction, an intellectual disability, mental illness, multiple sclerosis, muscular dystrophy, musculoskeletal disorders, neurological disorders, including stroke and epilepsy, paraplegia, quadriplegia and other spinal cord conditions, sickle cell anemia, ulcerative colitis, specific learning disabilities, or end stage renal failure disease; and
 - b) substantially limits one or more of the person's major life activities.Another disability or combination of disabilities may also be considered as a severe disability for the purposes of item (a) of this subdivision if it is determined by an evaluation of the rehabilitation potential to cause a comparable degree of substantial functional limitation similar to the specific list of disabilities listed in item (a) of this subdivision.
- Certification means a determination made by the Business Enterprise Council for Minorities, Women, and Persons with Disabilities, or by one delegated authority from the Council to make certifications, or by a State agency with statutory authority to make such a certification, that a business entity is a business owned by a minority, woman, or person with a disability for whatever purpose.

Contractor/Subcontractor Workforce Plan

Initial Bid/Estimating Date: _____ Progress Reporting Date: _____

Check appropriate status:

_____ Contractor
 _____ Subcontractor

Company Name: _____

Address: _____

Contact Person: _____ Phone: _____

Project: _____

Date Work Started: _____ Percent Complete: _____ %

Job Categories (by Trade)	Total Est. Hrs. (Bid)	# Crew (Head Ct.)	# Minority (Head Ct.)	# Female (Head Ct.)	Planned Minority Hrs.	Planned Female Hrs.	Actual Minority Hrs. to date	Actual Female Hrs. to date
Example: Carpenter	1,000	4	1	0	250	0		
Example: Painter	300	3	1	1	100	100		
Total								

Document Purpose:

This document is a tool to estimate the number and areas of work concerning minority and female labor hours anticipated on this job.

The apparent low bidder and their subcontractors listed on the bid documents shall submit this form within one week after bid opening to the Peoria Park District.

This tool is also a means of tracking the minority and female hours on this job. This document shall be attached to each invoice to show actual minority and female hours on this job.

<i>Job Categories (by Trade)</i>	<i>List of Workers Trade Name</i>
<i>Total Est. Hrs. (Bid)</i>	<i>Total hours of each of the trade listed</i>
<i># Crew (Head Ct.)</i>	<i>Total crew head count of each of the trade listed</i>
<i># Minority (Head Ct.)</i>	<i>Total Minority head count (it is subset of Total Crew #)</i>
<i># Females (Head Ct.)</i>	<i>Total Female head count (it is subset of Total Crew #)</i>
<i>Planned Minority Hrs.</i>	<i>Planned Minority hours of each of the trade listed</i>
<i>Planned Female Hrs.</i>	<i>Planned Female hours of each of the trade listed</i>

APPENDIX A OF 44 IL ADMIN CODE 750
EQUAL EMPLOYMENT OPPORTUNITY

In the event of the contractor's non-compliance with the provisions of this Equal Employment Opportunity Clause or the Act, the contractor may be declared ineligible for future contracts or subcontracts with the State of Illinois or any of its political subdivisions or municipal corporations, and the contract may be cancelled or voided in whole or in part, and other sanctions or penalties may be imposed or remedies invoked as provided by statute or regulation. During the performance of this contract, the contractor agrees as follows:

- 1) That he or she will not discriminate against any employee or applicant for employment because of race, color, religion, sex, sexual orientation, marital status, order of protection status, national origin or ancestry, citizenship status, age, physical or mental disability unrelated to ability, military status or an unfavorable discharge from military service; and, further, that he or she will examine all job classifications to determine if minority persons or women are underutilized and will take appropriate affirmative action to rectify any underutilization.
- 2) That, if he or she hires additional employees in order to perform this contract or any portion of this contract, he or she will determine the availability (in accordance with this Part) of minorities and women in the areas from which he or she may reasonably recruit and he or she will hire for each job classification for which employees are hired in a way that minorities and women are not underutilized.
- 3) That, in all solicitations or advertisements for employees placed by him or her or on his or her behalf, he or she will state that all applicants will be afforded equal opportunity without discrimination because of race, color, religion, sex, sexual orientation, marital status, order of protection status, national origin or ancestry, citizenship status, age, physical or mental disability unrelated to ability, military status or an unfavorable discharge from military service.
- 4) That he or she will send to each labor organization or representative of workers with which he or she has or is bound by a collective bargaining or other agreement or understanding, a notice advising the labor organization or representative of the contractor's obligations under the Act and this Part. If any labor organization or representative fails or refuses to cooperate with the contractor in his or her efforts to comply

with the Act and this Part, the contractor will promptly notify the Department and the contracting agency and will recruit employees from other sources when necessary to fulfill its obligations under the contract.

- 5) That he or she will submit reports as required by this Part, furnish all relevant information as may from time to time be requested by the Department or the contracting agency, and in all respects comply with the Act and this Part.
- 6) That he or she will permit access to all relevant books, records, accounts and work sites by personnel of the contracting agency and the Department for purposes of investigation to ascertain compliance with the Act and the Department's Rules and Regulations.
- 7) That he or she will include verbatim or by reference the provisions of this clause in every subcontract awarded under which any portion of the contract obligations are undertaken or assumed, so that the provisions will be binding upon the subcontractor. In the same manner as with other provisions of this contract, the contractor will be liable for compliance with applicable provisions of this clause by subcontractors; and further it will promptly notify the contracting agency and the Department in the event any subcontractor fails or refuses to comply with the provisions. In addition, the contractor will not utilize any subcontractor declared by the Illinois Human Rights Commission to be ineligible for contracts or subcontracts with the State of Illinois or any of its political subdivisions or municipal corporations.

**ATTACHMENT C –
DIRECTORY OF MINORITY & WOMEN OWNED BUSINESS ENTERPRISES**

Directory of Minority & Women Owned Business Enterprises Peoria Park District

MBE-Minority Owned Business Enterprise • WBE-Women Owned Business Enterprise • DOB-Persons with Disability Owned Business Enterprise
VOB-Veteran Owned Business Enterprise • SDV-Service Disabled Veteran Owned Business Enterprise

3 Keys Construction (MBE) Tray Keys	Construction Management 2314 Lehman Rd, Peoria, IL 61604	309-472-2721 traykeys@gmail.com
4th Distribution LLC, The (MBE) Samuel Stidwell	Commercial Building Materials 206 N Randolph St, 2nd Floor, Champaign, Illinois 61822	217-655-4174 info@the4thdistribution.com
A. Lucas & Sons Steel (WBE) Margaret Hanley	Structural Steel Fabrication 1328 SW Washington, Peoria, IL 61602	309-673-8547 Margaret@alucasiron.com
Ace In The Hole (WBE) Willa Warnkes-Sipp	Asphalt 15820 McDonald Rd, Hanna City, IL 61536	309-231-4556 patchem1@yahoo.com
AFE Construction LLC (MBE/WBE) Tommy and Monica Arbuckle	General Contractor 2216 W Altorfer Dr, Suite #2, Peoria, IL 61615	309-473-8688 309-208-3092 Cell admin@afeconstruction.net tommy@afeconstruction.net
Agile Supply Company (MBE)	Commercial Building Materials 706 West Bradley Ave, Urbana, IL 61801	217-729-2686 sales@agilesupplycompany.com
Alexander Brothers Construction Co (MBE) Arielle Alexander	Concrete, Demolition, Excavation, Landscaping PO Box 1508, Peoria, IL 61605 alexanderbrothers1997@gmail.com	309-713-3010
Alexander & Sons Construction (MBE) Leonard Alexander	Driveways, Curbs, Foundations, Layouts, Sidewalks, etc. 2415 N. Linn Street, Peoria, IL 61604 Leonardalexander1467@yahoo.com	773-628-9064 Cell
Allworld Project Management LLC (MBE) Ronnie Foster Jr	Highway, Street & Bridge Construction, Water & Sewer Line and Related Construction, Landscaping, Civil Engineering 415 South Front Street, Suite 121, Memphis, TN 38103	901-881-2985 info@allworldmail.com
Architectural Design Group, Inc (WBE) Deborah Jean Baker	Architect Services 800 SW Adams St, Peoria, IL 61602	309-672-6498 dbaker@archdesigngrp.com
Bautista Electric Enterprises Inc (MBE)	Electrical 1204 W Eads St, Urbana, IL 61801	217-637-0659 Bautistaelectricinc@gmail.com
Ben Hendricks Trucking Inc (WBE) Miranda Hendricks	Trucking, Freight 460 W Vine St, Canton, IL 61520 benhendrickstrucking@gmail.com	815-289-7994 309-647-6878
Black Squirrel Contracting (MBE) Joshua Wessels	Concrete, Painting 2037 N Aspen Road, Peoria, IL 61604	309-369-7817 blackssquirrel@yahoo.com
BMI Contractors & Assoc (MBE) Sammy Hobson	Excavation, Concrete, Demolition 1123 MacQueen, Peoria, IL 61604	309-657-4469 bmicontractors@yahoo.com
BOWA Group, The (MBE) Lee Fantroy	General 7050 S Stony Island Ave, Chicago, IL 60649	312-238-9899 lfantroy@thebowagroup.com
BPI Testing LLC (WBE)	HVAC Building Testing Services 2911 Gill Street, Ste 1A, Bloomington, IL 61704	309-663-1500 bpi@bpitestingllc.com
Buddy's Grounds Maintenance Inc (MBE) Dexter Davis	Landscaping PO Box 1125, Bloomington, IL 61702	309-824-9211 Dexterdavis2@aol.com
Built United (MBE) John Sutherland	General Contractor, Carpentry 921 S. Bosch Rd, Unit B, Peoria, IL 61607	309-699-9191 john@builtunited.com
Burnside Brothers Construction (MBE) Terry Burnside	Landscaping, General Construction 3563 SW Adams, Peoria, IL 61605	309-922-9390 terryburnside@hotmail.com
C Lindsay Sealcoating (MBE)	Paving & Asphalt Serving Peoria & Surrounding Areas	309-291-9352 309-453-8162 clindsay44@yahoo.com

C & G Concrete Construction Co Inc (WBE) Patricia Slusher	Concrete East Peoria, IL 61611	309-699-0384 309-208-4601 Cell Rodney@cngconcrete.com tricia@cngconcrete.com
CAD Construction (WBE) Kerry Keller	General Contractor 150 S Baer Rd, Tremont, IL 61568 admin@cadconstructioninc.com	309-925-2092
Central IL Consulting (WBE) Jessica Youngman	Land Surveying 531 Parkside Drive, Washburn, IL 61570	309-383-3156 youngman@mtco.com
Central Landscaping (WBE) Donna Brandenburg	Seeding, Landscaping 12512 Mendell Rd, Princeville, IL 61559	309-385-4832 cntrland@frontier.com
CJL Landscaping Inc (WBE) Rebecca Kelch	Landscaping 10902 W US Highway 150, Brimfield, IL 61517	309-691-9200 Meinders_81@yahoo.com jrdoering@att.net
Clevenger Contractors Inc (WBE) Verlee Clevenger, Misty L. Daham	Guardrail, Bridge Rail, Seeding, Fencing 355 Naples Rd, PO Box 19, Bluffs, IL 62621	217-754-3411 clever@irtc.net
CNS Forestry & Landscaping (WBE)	Forestry & Landscaping 1813 1000 th St, Lincoln, IL 62656	217-792-3808
Concrete to Perfection (MBE/WBE) Elonda Whitfield	Concrete (Repair, Design, Protect, Patching) and Counter Tops 3510 N Kingston Dr Unit 21, Peoria, IL 61604 concretetoperfection@gmail.com	309-681-9508 309-472-0215 Cell
Cook Fasser (WBE)	Roofing Supplies 5835 N Galena Road, #201, Peoria, IL 61614	309-682-1600 manderson@cookfasser.com
Cordova Construction (WBE) Tina Christopher	Landscaping, Dirt Work, Concrete Removal, Curb & Gutter Removal, Sidewalk Removal 2424 N Ellory Road, Peoria, IL 61615	309-208-3448 Cell tinac18827@yahoo.com
Cranford Plumbing (WBE)	Plumbing PO Box 755, Dunlap, IL 61525	309-697-3484
Cronkhite Painting & Decorating Inc (WBE) Amy Cronkhite	Painting 1925 Woodland Knolls Rd, Metamora, IL 61548	309-208-6237 amy@cronkhitepainting.com
CSS (Construction Specialties & Services) (MBE) Dave Suzuki	Building Specialties, Design, Engineering, Estimating PO Box 120703, Peoria, IL 61614	309-685-8453 css@sai-x.com cssco@sai-x.com
Custom Underground Inc (WBE) Diane Feuchter	Directional Boring, Fiber Optic Splicing, Utility Construction 9907 W US Highway 150, Edwards, IL 61528	309-683-3677 mail@customug.com
CWG Inc (WBE) Teresa Gustafson	Demolition, Excavation, Trucking 24635 Cooper Rd, Morton, IL 61550	309-208-5461 Cell 309-208-8899 Cell
Dashco, Inc (WBE)	Insulation, siding, windows, soffits, gutters, rain/gutter guard 4901 S Becker Dr, Bartonville, IL 61607	309-633-1383 debbie@dashco.site
DECA Realty & DECA Properties (MBE) Eddie J. Washington	Real Estate Broker, Appraiser & Properties 417 W Main, Peoria, IL 61606	309-637-3322 washingtoned48@gmail.com
Design Air Inc (MBE) Christopher Eston	Commercial Air Duct Cleaning 6625 N Big Hollow Rd # 312, Peoria, IL 61615	309-693-8632 cle@designair-inc.com
Drummond Construction LLC (MBE) Charles Drummond	Sewage and stormwater treatment works or nonpoint source projects 1609 S Griswold, Peoria IL 61605	309-643-2757 drummondcharles9@gmail.com
Earth Care Unlimited Inc (WBE) Monica Thornley	Landscaping, Seeding, Sodding 3108 Panther Grove Rd, Ashland, IL 62612 earthcareunlimited@yahoo.com	217-452-7370 217-414-4321
EB Home Improvement LLC (MBE) Elbert Billups	Painting Peoria, IL	309-420-2846 billupselbert@gmail.com
Elite Armour Roofing (MBE)	Roofing, Siding, Gutters, Fascia, Soffits Dunlap, IL	800-327-4987 elitearmourroofing@gmail.com
Foster-Jacob Electric (WBE) Emily Rudesill	Electrical 826 W Main St, Peoria, IL 61606	309-674-8129 emilyj@fosterjacob.com

Fosters Custom Painting (WBE)	Painter Peoria, IL fosterscustompainting@yahoo.com	309-208-7538
Fritch Heating & Cooling (WBE)	HVAC 1004 NE Adams, Peoria, IL 61603	309-671-5360
G.A. Rich & Sons (WBE)	Mechanical and Utility Contractor, Commercial Plumbing 204 S Perry, Deer Creek, IL 61733	309-447-6231 info@garich.com
Garza Heating & Cooling (MBE)	HVAC 1304 S Western Ave, Peoria, IL 61605	309-645-6294 carlosgarza@gmail.com
Horowitz Concrete (WBE)	Concrete 128 Legion Lane, East Peoria, IL 61611	309-208-4757
Ronald A. Givens & Associates (MBE) Ronald A. Givens	Insurance & Investments 2616 N Lehman, Peoria, IL 61602	309-685-4588
GIVSCO Construction (MBE) Ronald Givens	General Contractor 2323 Lakeshore Dr, Suite B, Pekin, IL 61554	309-620-9127 info@givSCO.com
Gutters & More (WBE) Kris Rainey	Gutters 157 Thunderbird Ln, East Peoria, IL 61611	309-694-4000 ksr@gutters-more.com
H & S Mechanical Inc (WBE) Tara Howard	Mechanical, Structural Steel and Electrical Contractor 5607 S Washington St, Bartonville, IL 61607	309-696-7066 tara@hsmmechanicalinc.com
Hanley Industrial Services (VOB) Jim Hanley	Drafting & Design, Metal Supplies (Incl. Fabricated Steel), Highway Products, Consulting 8811 N. Industrial Road, Suite A, Peoria, IL 61615 jim@hanleyindustrialservices.com	309-261-9941
Hermann & Associates (WBE) Alisha Hermann	Consultant Engineering 4603 N Galena Rd, Peoria Heights, IL 61616 ahermann@hermannassoc.com	309-687-5566
Illinois Mechanical Service & Design (WBE) Beth Ward	HVAC PO Box 10494, Peoria, IL 61612	309-713-3640 309-713-2995 Fax service@illmsd.com
Infrastructure Engineering (MBE)	Civil Engineering 456 Fulton St, Suite 256, Peoria, IL 61602 eandrews@infrastructure-eng.com	309-637-9200 309-637-9210
Intech Innovations (SDV) John McCrary	Audio/Video Design and Integration Washington, IL 61571 jmccrary@intechinnovations.com	309-481-4361
Interlock Brick Paving (WBE) Chris Joos	Hardscaping, Landscaping, Excavating PO Box 6, Morton, IL 61550	309-696-9264
JC Construction (MBE) Frank Coates	General 1810 Stever, Peoria, IL 61605	309-303-3919 Cell
JD Traffic Inc (WBE)	Traffic Control Equipment 4200 S Ricketts Ave, Bartonville, IL	309-966-4494 Jordan@JD-Traffic.com
JM Industrial Supply (MBE/VOB) Ron Given	Maintenance Items, Tools, Soaps 2323 Lakeshore, Pekin, IL 61554	309-346-5796 sales@jmindsupply.com
Jones Electrical Contractors Inc (MBE/VOB) Ronald Jones	Electrical 5611 W Rachael Dr, Peoria, IL 61615	309-339-7690
Kadilex Construction Inc (MBE)	Rebar Installation P.O. Box 348 Wood River, IL 62095	618-216-2621 info@kadilexconstruction.com
Kelley Ironworks (WBE) Tania Hoerr	Fencing, Railings and Ironwork 4303 N Main St, East Peoria, IL 61611	309-697-9870 309-208-5207 Cell tania@kelleyiron.com
Kemper Construction (WBE)	General Contractor 423 Enterprise Dr, Canton, IL 61520	309-647-3836

Kerry Brown Trucking (MBE) Leo K. Brown	Tandem, Semi Dump, General Hauling Peoria, IL	309-251-6089 Cell leok.brown1957@gmail.com
Kreiling Roofing Co (WBE)	Residential & Commercial single ply, BUR, coatings, metal roofing, shingles, tile, slate, wood shake, with custom sheet metal details and copper work 2335 W Altorfer Dr, Peoria, IL 61615	309-673-3649 kdimler@kreiling.com
Lewis Michael Construction (MBE/WBE) Andre McKnight	Janitorial & Construction Clean-Up 2000 W Pioneer Parkway, Ste 7, Peoria, IL61615	309-686-7107 lmcm2@comcast.net
LIZZ Trucking & Hauling (MBE) Brandon Hines	Trucking/Hauling Peoria, IL 61604	309-208-5942 lizztrucking@yahoo.com
Los Amigos Concrete Construction (MBE)	Concrete Peoria, IL	309-863-6495 Eddievega599@yahoo.com
LNR Construction (MBE) Lavael Randle Sr	General Construction 2200 N Linsley St, Peoria, IL 61605	309-678-3314 Cell
M & A Plumbing (MBE) Michael Abner	Plumbing 6216 N Devonshire Avenue, Peoria, IL 61615	309-689-0133 mabner1953@icloud.com
McGinnis Transportation (WBE) Beth McGinnis	Trucking, Tandem, 24" Box Truck 336 Riverview Drive, Creve Coeur, IL 61610	309-369-4465
Millennia Professional Services of IL (MBE) Thomas Ngo	Civil Engineering, Surveying, Materials Testing 850 N Main St., Morton, IL 61550	309-321-8141 tngo@millennia.pro
Molleck Electric (WBE)	Electrical 14926 W Winchester Dr, Brimfield, IL 61517	309-446-3483 dmolleck@yahoo.com
Montefusco HVAC (WBE) Lisa Rhoades	HVAC 2400 W Park 74 Drive, Peoria, IL 61615	309-691-7400 309-208-6233 lisa@montefuscohvac.com
Murillo Concrete (MBE) Javier Murillo	Concrete Dunlap, IL	309-397-6852 murilloconcrete@gmail.com
Oberlander Electric (MBE) Chad Gardner	Electrical 1300 E Gardner Drive, Mossville, IL 61552	309-657-0259 309-694-1468 cgardner@obie.biz 309-745-5763
Ogborn Plumbing (WBE)	Plumbing 311 Peach, Washington, IL 61571	
Peoria Brick Company (WBE)	Brick and Stone Supply 501 Cole Street, East Peoria, IL 61611	309-699-1116 info@peoriabrick.com
Peoria Metro Construction Inc (WBE) Courtney Meischner	General Contractor, Concrete Contractor 1925 S Darst St, Peoria, IL 61607	309-671-1466 info@peoriametro.com
Phoenix Corporation (WBE)	Trucking and Excavating 1006 Rosehill Rd. Port Byron IL 61275	309-523-3687 estimating@phoenixcorp.org
Pizano Electric Inc (MBE)	Electrical 716 24th St. Rock Island, IL 61201	309-373-7808 pizanoelectrical@gmail.com
Point Construction Company (MBE) Juan Madrigal	Roofing, Siding, Carpentry Peoria, IL 61614	309-635-9074 jjm025@gmail.com
Prairie Engineers of Illinois PC (WBE) Colleen Ayars	Civil Engineering, Surveying, Environmental Consulting 926 SW Adams Street, Suite 120, Peoria, IL 61602 www.prairieengineers.com	309-839-2642
Quick Electrical Contractors Inc (WBE) Lisa Quick	Electrical 445 Carter St, PO Box 49, Fairview, IL 61432	309-778-2000 lq@quickelectric.net
Rainforcing Roofing and Exteriors (MBE/WBE)	Roofing, Siding, Gutters 2617 N Sheridan Rd, Peoria, IL	309-989-3279 rainforcing.roof2022@gmail.com
Reign Construction (MBE/WBE) Bridget Booker	Iron Worker, Structural, Bridges, Rebar, Fabrication, Welding, Rigging, and Ornamental 801 W Main St, Suite A118, Peoria, IL 61606 bridget@reignconstructioninc.com	309-495-7284 309-750-4846 Cell

R.J. Rhodes Electric (MBE) Richard Joseph Rhodes	Electrical 4210 N Northbrook Ct, Peoria, IL 61614 Richard_rhodes2001@yahoo.com	309-989-7931
RNS Electric Inc (WBE) Regina Slonneger	Electrical 28558 Irish Lane, Washington, IL 61571	309-444-5200 gina@rnselectricinc.com ty@rnselectricinc.com
Rob Johnson Trucking (WBE) Jessica Johnson	Trucking East Peoria, IL 61611	309-251-2756 jessicamjohnson_80@yahoo.com
Rustic Oaks Lawn & Landscaping (MBE) Kameron Velasquez	Concrete, Landscape Design, Installation, and Maintenance East Peoria, IL 61611 office@rusticoakslandscaping.com	309-966-0689
Searle Trucking Inc (WBE) Debbie Searle	Trucking/Hauling, Trailors, Flat Dump PO Box 1084, Peoria, IL 61653	309-686-0708 searletrkn@comcast.net
Serenity Electric (MBE)	Electrical PO Box 6521, Peoria, IL 61601 jamesltaylor1955@yahoo.com	309-363-5067 Cell
Sheridan Road Lumber (WBE)	Lumber and Materials Provider 6600 N Sheridan Road, Peoria, IL 61614	309-691-0858 info@srlco.com
Sierra Glass Company (MBE)	Glass Supply 301 N. Neil Street Suite 400, Champaign, IL 61820 antwuan@sierraglasscompany.com	217-239-0644
Standard Heating & Cooling (WBE)	HVAC 906 SW Adams, Peoria, IL 61602	309-671-5417 bewalt@standardheat.com
Stoops Plumbing (WBE) Jennifer Stoops	Plumbing PO Box 320, Mackinaw, IL 61755	309-494-9500 jennifer@stoopsplumbing.com
Tabitha Ventures Inc (MBE) Edward O Taiwo	General Construction & Management 2217 N Woodcrest Dr #3E, Dunlap, IL 61525	309-692-1473 info@tabithainc.com
Thompson Brothers Inc (MBE) Todd Thompson	General Carpentry and Construction, Interior Finish Work, Millwork PO Box 313, Pekin, IL 61555	309-613-0254 office@tbrosinc.com
Tiles in Style LLC (MBE/WBE) dba Taza Supplies dba Taza Construction	Flooring Solutions Construction Materials General Construction 16940 Vincennes Ave, South Holland, IL	sales@tilesinstyle.com sales@tazasupplies.com sales@tazaconstruction.com 877-817-2841
Titan Industries (WBE)	Steel Fabrication 100 Prospect Dr, Deer Creek, IL 61733	309-440-1010
TSI Commercial Floor Covering (WBE)	Flooring 3611 N Staley Rd, Suite #1, Champaign, IL 61822	217-328-7321 marci.smith@tsicfcacr.com
Universal Paintings and Coatings (WBE)	Painting & Wallpapering 390 Wildwood Dr, Groveland, IL 61535	309-253-1569 universalcoatingsllc@gmail.com
Veya Inc (MBE)	Concrete, Curbs & Gutters, Excavation 601 S. Country Fair Drive, Champaign, IL 61821	217-607-1500 patrick@veyainc.com
Western Asphalt Inc (WBE)	Environmental Remediation & Restoration, Excavation, Demolition 2665 Prairie College Rd. Jacksonville, IL 62650	217-243-3822 info@workwithwestern.com
Will Heating & Cooling (MBE)	HVAC 2825 Humboldt, Peoria IL 61605	309-839-5280 dallaswilliams73@gmail.com
Willis Electric (WBE) Phyllis Willis	Electrical PO Box 545, Chillicothe, IL 61523	309-579-2926 309-208-3415 Cell

**ATTACHMENT D –
PREVAILING WAGES FOR PEORIA COUNTY – ILLINOIS DEPARTMENT OF LABOR**

Peoria County Prevailing Wage Rates posted on 3/2/2026

Trade Title	Rg	Type	C	Base	Foreman	Overtime					Pension	Vac	Trng	Other Ins	Add OT 1.5x owed	Add OT 2.0x owed
						M-F	Sa	Su	Hol	H/W						
ASBESTOS ABT-GEN	All	BLD		36.00	37.50	1.5	1.5	2.0	2.0	8.90	23.58	0.00	0.80	0.00	2.51	5.02
ASBESTOS ABT-GEN	All	HWY		38.07	39.57	1.5	1.5	2.0	2.0	8.90	28.44	0.00	0.80	0.00	4.20	8.39
ASBESTOS ABT-MEC	All	BLD		35.18	38.00	1.5	1.5	2.0	2.0	16.44	14.75	0.00	0.92		2.43	4.84
BOILERMAKER	All	BLD		50.46	54.46	1.5	1.5	2.0	2.0	7.07	24.29	0.00	2.34	0.00	16.38	32.76
BRICK MASON	All	BLD		39.50	41.87	1.5	1.5	2.0	2.0	12.45	16.63	0.00	1.25		0.00	0.00
CARPENTER	All	BLD		39.06	41.81	1.5	1.5	2.0	2.0	9.95	23.19	0.00	0.81	0.00	16.57	33.14
CARPENTER	All	HWY		40.96	43.21	1.5	1.5	2.0	2.0	9.95	24.87	0.00	0.78	0.00	0.00	0.00
CEMENT MASON	All	BLD		35.96	38.71	1.5	1.5	2.0	2.0	9.00	24.00	0.00	0.86	0.00	0.00	0.00
CEMENT MASON	All	HWY		39.43	41.93	1.5	1.5	2.0	2.0	9.00	23.67	0.00	0.80	0.00	0.00	0.00
CERAMIC TILE FINISHER	All	BLD		36.21		1.5	1.5	2.0	2.0	12.45	16.63	0.00	1.24		0.00	0.00
ELECTRIC PWR EQMT OP	All	ALL		59.91	71.10	1.5	1.5	2.0	2.0	9.30	16.78	0.00	0.60	0.00	0.00	0.00
ELECTRIC PWR GRNDMAN	All	ALL		40.71	71.10	1.5	1.5	2.0	2.0	8.72	11.40	0.00	0.41	0.00	0.00	0.00
ELECTRIC PWR LINEMAN	All	ALL		66.69	71.10	1.5	1.5	2.0	2.0	9.50	18.67	0.00	0.67	0.00	0.00	0.00
ELECTRIC PWR TRK DRV	All	ALL		45.45	71.10	1.5	1.5	2.0	2.0	8.86	12.72	0.00	0.45	0.00	0.00	0.00
ELECTRICIAN	All	BLD		46.70	50.20	1.5	1.5	2.0	2.0	10.00	16.45	0.00	0.90	0.00	0.00	0.00
ELECTRONIC SYSTEM TECH	All	BLD		37.70	40.70	1.5	1.5	2.0	2.0	8.85	14.15	0.00	0.40	0.00	0.00	0.00
ELEVATOR CONSTRUCTOR	All	BLD		60.52	68.09	2.0	2.0	2.0	2.0	16.37	21.76	4.84	0.85		0.00	0.00
GLAZIER	All	BLD		41.24	43.24	1.5	1.5	1.5	2.0	15.87	11.51	0.00	1.40	0.00	0.00	0.00
HEAT/FROST INSULATOR	All	BLD		46.91	49.72	1.5	1.5	2.0	2.0	16.44	17.08	0.00	0.92		3.59	7.17
IRON WORKER	All	BLD		39.24	41.14	1.5	1.5	2.0	2.0	12.71	20.26	0.00	0.91	0.00	0.00	0.00
IRON WORKER	All	HWY		45.48	47.48	1.5	1.5	2.0	2.0	12.71	20.26	0.00	1.16	0.00	0.00	0.00
LABORER	All	BLD		34.00	35.50	1.5	1.5	2.0	2.0	8.90	23.58	0.00	0.80	0.00	2.51	5.02
LABORER	All	HWY		37.32	38.82	1.5	1.5	2.0	2.0	8.90	28.44	0.00	0.80	0.00	4.20	8.39
LABORER, SKILLED	All	BLD		34.40	35.90	1.5	1.5	2.0	2.0	8.90	23.58	0.00	0.80	0.00	2.51	5.02
LABORER, SKILLED	All	HWY		37.62	39.12	1.5	1.5	2.0	2.0	8.90	28.44	0.00	0.80	0.00	4.20	8.39
LATHER	All	BLD		39.06	41.81	1.5	1.5	2.0	2.0	9.95	23.19	0.00	0.81	0.00	16.57	33.14
MACHINERY MOVER	All	HWY		45.48	47.48	1.5	1.5	2.0	2.0	12.71	20.26	0.00	1.16	0.00	0.00	0.00

Peoria County Prevailing Wage Rates posted on 3/2/2026

MACHINIST	All	BLD		60.39	64.39	1.5	1.5	2.0	2.0	11.43	9.95	1.85	1.47	0.00	0.00	0.00
MARBLE FINISHER	All	BLD		36.21		1.5	1.5	2.0	2.0	12.45	16.63	0.00	1.24		0.00	0.00
MARBLE MASON	All	BLD		39.92	42.32	1.5	1.5	2.0	2.0	12.45	16.63	0.00	1.26		0.00	0.00
MILLWRIGHT	All	BLD		39.10	41.85	1.5	1.5	2.0	2.0	9.95	23.53	0.00	0.81	0.00	16.74	33.48
MILLWRIGHT	All	HWY		42.00	44.25	1.5	1.5	2.0	2.0	9.95	24.50	0.00	0.78	0.00	0.00	0.00
OPERATING ENGINEER	All	BLD	1	47.79	50.79	1.5	1.5	2.0	2.0	12.85	26.97	0.00	3.60		0.00	0.00
OPERATING ENGINEER	All	BLD	2	44.09		1.5	1.5	2.0	2.0	12.85	26.97	0.00	3.60		0.00	0.00
OPERATING ENGINEER	All	BLD	3	38.03		1.5	1.5	2.0	2.0	12.85	26.97	0.00	3.60		0.00	0.00
OPERATING ENGINEER	All	HWY	1	47.79	51.29	1.5	1.5	2.0	2.0	12.85	26.97	0.00	3.60		0.00	0.00
OPERATING ENGINEER	All	HWY	2	44.09		1.5	1.5	2.0	2.0	12.85	26.97	0.00	3.60		0.00	0.00
OPERATING ENGINEER	All	HWY	3	38.03		1.5	1.5	2.0	2.0	12.85	26.97	0.00	3.60		0.00	0.00
PAINTER	All	ALL		42.40	44.40	1.5	1.5	1.5	2.0	15.13	12.32	0.00	1.50	0.00	0.00	0.00
PAINTER - SIGNS	All	BLD		48.16	54.11	1.5	1.5	2.0	2.0	8.20	16.81	0.00	0.00	0.00	0.00	0.00
PILEDRIIVER	All	BLD		41.06	43.81	1.5	1.5	2.0	2.0	9.95	23.19	0.00	0.81	0.00	16.57	33.14
PILEDRIIVER	All	HWY		41.96	44.21	1.5	1.5	2.0	2.0	9.95	24.87	0.00	0.78	0.00	0.00	0.00
PIPEFITTER	All	BLD		46.60	51.73	1.5	1.5	2.0	2.0	9.95	17.49	0.00	1.65	0.00	0.00	0.00
PLASTERER	All	BLD		34.25	36.25	1.5	1.5	2.0	2.0	9.00	25.10	0.00	0.99		0.00	0.00
PLUMBER	All	BLD		42.70	47.40	1.5	1.5	2.0	2.0	9.95	19.33	0.00	1.70	0.00	0.00	0.00
ROOFER	All	BLD		38.05	40.90	1.5	1.5	2.0	2.0	10.75	13.26	0.00	0.50	0.00	0.00	0.00
SHEETMETAL WORKER	All	BLD		40.48	42.50	1.5	1.5	2.0	2.0	12.42	20.68	0.00	1.29	0.00	0.00	0.00
SIGN HANGER	All	HWY		45.48	47.48	1.5	1.5	2.0	2.0	12.71	20.26	0.00	1.16	0.00	0.00	0.00
SPRINKLER FITTER	All	BLD		50.51	53.76	1.5	1.5	2.0	2.0	12.40	17.31	0.00	0.54	0.00	0.00	0.00
STEEL ERECTOR	All	HWY		45.48	47.48	1.5	1.5	2.0	2.0	12.71	20.26	0.00	1.16	0.00	0.00	0.00
STONE MASON	All	BLD		39.50	41.87	1.5	1.5	2.0	2.0	12.45	16.63	0.00	1.25		0.00	0.00
TERRAZZO FINISHER	All	BLD		36.21		1.5	1.5	2.0	2.0	12.45	16.63	0.00	1.24		0.00	0.00
TERRAZZO MASON	All	BLD		39.92	42.32	1.5	1.5	2.0	2.0	12.45	16.63	0.00	1.26		0.00	0.00
TILE MASON	All	BLD		39.92	42.32	1.5	1.5	2.0	2.0	12.45	16.63	0.00	1.26		0.00	0.00
TRUCK DRIVER	All	ALL	1	45.29	49.65	1.5	1.5	2.0	2.0	17.11	8.06	0.00	0.25	0.00	0.00	0.00
TRUCK DRIVER	All	ALL	2	45.88	49.65	1.5	1.5	2.0	2.0	17.11	8.06	0.00	0.25	0.00	0.00	0.00
TRUCK DRIVER	All	ALL	3	46.15	49.65	1.5	1.5	2.0	2.0	17.11	8.06	0.00	0.25	0.00	0.00	0.00

Peoria County Prevailing Wage Rates posted on 3/2/2026

TRUCK DRIVER	All	ALL	4	46.54	49.65	1.5	1.5	2.0	2.0	17.11	8.06	0.00	0.25	0.00	0.00	0.00
TRUCK DRIVER	All	ALL	5	47.64	49.65	1.5	1.5	2.0	2.0	17.11	8.06	0.00	0.25	0.00	0.00	0.00
TRUCK DRIVER	All	O&C	1	36.23	39.72	1.5	1.5	2.0	2.0	17.11	8.06	0.00	0.25	0.00	0.00	0.00
TRUCK DRIVER	All	O&C	2	36.70	39.72	1.5	1.5	2.0	2.0	17.11	8.06	0.00	0.25	0.00	0.00	0.00
TRUCK DRIVER	All	O&C	3	36.92	39.72	1.5	1.5	2.0	2.0	17.11	8.06	0.00	0.25	0.00	0.00	0.00
TRUCK DRIVER	All	O&C	4	37.23	39.72	1.5	1.5	2.0	2.0	17.11	8.06	0.00	0.25	0.00	0.00	0.00
TRUCK DRIVER	All	O&C	5	38.11	39.72	1.5	1.5	2.0	2.0	17.11	8.06	0.00	0.25	0.00	0.00	0.00
TUCK POINTER	All	BLD		39.50	41.87	1.5	1.5	2.0	2.0	12.45	16.63	0.00	1.25		0.00	0.00

Legend

Rg Region

Type Trade Type - All,Highway,Building,Floating,Oil & Chip,Rivers

C Class

Base Base Wage Rate

OT M-F Unless otherwise noted, OT pay is required for any hour greater than 8 worked each day, Mon through Fri. The number listed is the multiple of the base wage.

OT Sa Overtime pay required for every hour worked on Saturdays

OT Su Overtime pay required for every hour worked on Sundays

OT Hol Overtime pay required for every hour worked on Holidays

H/W Health/Welfare benefit

Vac Vacation

Trng Training

Other Ins Employer hourly cost for any other type(s) of insurance provided for benefit of worker.

Explanations PEORIA COUNTY

The following list is considered as those days for which holiday rates of wages for work performed apply: New Years Day, Memorial Day, Fourth of July, Labor Day, Thanksgiving Day, Christmas Day and Veterans Day in some classifications/counties. Generally, any of these holidays which fall on a Sunday is celebrated on the following Monday. This then makes work performed on that Monday payable at the appropriate overtime rate for holiday pay. Common practice in a given local may alter certain days of celebration. If in doubt, please check with IDOL.

Oil and chip resealing (O&C) means the application of road oils and liquid asphalt to coat an existing road surface, followed by application of aggregate chips or gravel to coated surface, and subsequent rolling of material to seal the surface.

EXPLANATION OF CLASSES

Peoria County Prevailing Wage Rates posted on 3/2/2026

ASBESTOS - GENERAL - removal of asbestos material/mold and hazardous materials from any place in a building, including mechanical systems where those mechanical systems are to be removed. This includes the removal of asbestos materials/mold and hazardous materials from ductwork or pipes in a building when the building is to be demolished at the time or at some close future date.

ASBESTOS - MECHANICAL - removal of asbestos material from mechanical systems, such as pipes, ducts, and boilers, where the mechanical systems are to remain.

CERAMIC TILE FINISHER, MARBLE FINISHER, TERRAZZO FINISHER

Assisting, helping or supporting the tile, marble and terrazzo mechanic by performing their historic and traditional work assignments required to complete the proper installation of the work covered by said crafts. The term "Ceramic" is used for naming the classification only and is in no way a limitation of the product handled. Ceramic takes into consideration most hard tiles.

ELECTRONIC SYSTEMS TECHNICIAN

Installation, service and maintenance of low-voltage systems which utilizes the transmission and/or transference of voice, sound, vision, or digital for commercial, education, security and entertainment purposes for the following: TV monitoring and surveillance, background/foreground music, intercom and telephone interconnect, field programming, inventory control systems, microwave transmission, multi-media, multiplex, radio page, school, intercom and sound burglar alarms and low voltage master clock systems.

Excluded from this classification are energy management systems, life safety systems, supervisory controls and data acquisition systems not intrinsic with the above listed systems, fire alarm systems, nurse call systems and raceways exceeding fifteen feet in length.

LABORER, SKILLED - BUILDING

The skilled laborer building (BLD) classification shall encompass the following types of work, irrespective of the site of the work: cutting & acetylene torch, gunnite nozzlemen, gunnite pump men & pots, kettlemen & carriers of men handling hot stuff, sandblaster nozzle men, sandblasting pump men & pots, setting up and using concrete burning bars, wood block setters, underpinning & shoring of existing buildings, and the unload-ing and handling of all material coated with creosote.

LABORER, SKILLED - HIGHWAY

The skilled laborer heavy & highway (HWY) classification shall encompass the following types of work,irrespective of the site of the work: jackhammer & drill operator, gunite pump & pot man, puddlers, vibrator men, wire fabric placer, sandblast pump & pot man, strike off concrete, unloading, handling & carrying of all creosoted piles, ties or timber, concrete burning bars, power wheelbarrows or buggies, asphalt raker, brickset-ters, cutting torchman (electric & acetylene), men setting lines to level forms, form setters, gunite nozzle man & sandblasting nozzle man, power man, and rip-rapping by hand.

TRUCK DRIVER - BUILDING, HEAVY AND HIGHWAY CONSTRUCTION Class 1. Drivers on 2 axle trucks hauling less than 9 ton. Air

Peoria County Prevailing Wage Rates posted on 3/2/2026

compressor and welding machines and brooms, including those pulled by separate units, truck driver helpers, warehouse employees, mechanic helpers, greasers and tiremen, pickup trucks when hauling materials, tools, or workers to and from and on-the-job site, and fork lifts up to 6,000 lb. capacity.

Class 2. Two or three axle trucks hauling more than 9 ton but hauling less than 16 ton. A-frame winch trucks, hydrolift trucks, vactor trucks or similar equipment when used for transportation purposes. Fork lifts over 6,000 lb. capacity, winch trucks, four axle combination units, and ticket writers.

Class 3. Two, three or four axle trucks hauling 16 ton or more. Drivers on water pulls, articulated dump trucks, mechanics and working forepersons, and dispatchers. Five axle or more combination units.

Class 4. Low Boy and Oil Distributors.

Class 5. Drivers who require special protective clothing while employed on hazardous waste work.

TRUCK DRIVER - OIL AND CHIP RESEALING ONLY.

This shall encompass laborers, workers and mechanics who drive contractor or subcontractor owned, leased, or hired pickup, dump, service, or oil distributor trucks. The work includes transporting materials and equipment (including but not limited to, oils, aggregate supplies, parts, machinery and tools) to or from the job site; distributing oil or liquid asphalt and aggregate; stock piling material when in connection with the actual oil and chip contract. The Truck Driver (Oil & Chip Resealing) wage classification does not include supplier delivered materials.

OPERATING ENGINEERS - BUILDING

Class 1. Cranes; Overhead Cranes; Gradall; All Cherry Pickers; Mechanics; Central Concrete Mixing Plant Operator; Road Pavers (27E - Dual Drum - Tri Batchers); Blacktop Plant Operators and Plant Engineers; 3 Drum Hoist; Derricks; Hydro Cranes; Shovels; Skimmer Scoops; Koehring Scooper; Drag Lines; Backhoe; Derrick Boats; Pile Drivers and Skid Rigs; Clamshells; Locomotive Cranes; Dredge (all types) Motor Patrol; Power Blades - Dumore - Elevating and similar types; Tower Cranes (Crawler-Mobile) and Stationary; Crane-type Backfiller; Drott Yumbo and similar types considered as Cranes; Caisson Rigs; Dozer; Tournadozer; Work Boats; Ross Carrier; Helicopter; Tournapulls - all and similar types; Scoops (all sizes); Pushcats; Endloaders (all types); Asphalt Surfacing Machine; Slip Form Paver; Rock Crusher; Heavy Equipment Greaser; CMI, CMI Belt Placer, Auto Grade & 3 Track and similar types; Side Booms; Multiple Unit Earth Movers; Creter Crane; Trench Machine; Pump-crete-Belt Crete-Squeeze Cretes-Screw-type Pumps and Gypsum; Bulker & Pump - Operator will clean; Formless Finishing Machine; Flaherty Spreader or similar types; Screed Man on Laydown Machine; Wheel Tractors (industrial or Farm-type w/Dozer-Hoe-Endloader or other attachments); F.W.D. & Similar Types; Vermeer Concrete Saw.

Class 2. Dinkeys; Power Launches; PH One-pass Soil Cement Machine (and similar types); Pugmill with Pump; Backfillers; Euclid Loader; Forklifts; Jeeps w/Ditching Machine or other attachments; Tuneluger; Automatic Cement and Gravel Batching Plants; Mobile Drills (Soil Testing) and similar types; Gurries and Similar Types; (1) and (2) Drum Hoists (Buck Hoist and Similar Types); Chicago Boom; Boring Machine & Pipe Jacking Machine; Hydro Boom; Dewatering System; Straw Blower; Hydro Seeder; Assistant Heavy Equipment Greaser on Spread; Tractors (Track type) without Power Unit pulling Rollers; Rollers on Asphalt -- Brick

Peoria County Prevailing Wage Rates posted on 3/2/2026

Macadem; Concrete Breakers; Concrete Spreaders; Mule Pulling Rollers; Center Stripper; Cement Finishing Machines & CMI Texture & Reel Curing Machines; Cement Finishing Machine; Barber Green or similar loaders; Vibro Tamper (All similar types) Self-propelled; Winch or Boom Truck; Mechanical Bull Floats; Mixers over 3 Bag to 27E; Tractor pulling Power Blade or Elevating Grader; Porter Rex Rail; Clary Screed; Truck Type Hoptoe Oilers; Fireman; Spray Machine on Paving; Curb Machines; Truck Crane Oilers; Oil Distributor; Truck-Mounted Saws.

Class 3. Air Compressor; Power Subgrader; Straight Tractor; Trac Air without attachments; Herman Nelson Heater, Dravo, Warner, Silent Glo, and similar types; Roller: Five (5) Ton and under on Earth or Gravel; Form Grader; Crawler Crane & Skid Rig Oilers; Freight Elevators - permanently installed; Pump; Light Plant; Generator; Conveyor (1) or (2) - Operator will clean; Welding Machine; Mixer (3) Bag and Under (Standard Capacity with skip); Bulk Cement Plant; Oiler on Central Concrete Mixing Plant.

OPERATING ENGINEERS - HEAVY AND HIGHWAY CONSTRUCTION

CLASS 1. Cranes; Hydro Cranes; Shovels; Crane Type Backfiller; Tower, Mobile, Crawler, & Stationary Cranes; Derricks; Hoists (3 Drum); Draglines; Drott Yumbo & Similar Types considered as Cranes; 360 Degree Swing Excavator (Shears, Grapples, Movacs, etc.); Back Hoe; Derrick Boats; Pile Driver and Skid Rigs; Clam Shell; Locomotive - Cranes; Road Pavers - Single Drum - Dual Drum - Tri Batcher; Motor Patrols & Power Blades - Dumore - Elevating & Similar Types; Mechanics; Central Concrete Mixing Plant Operator; Asphalt Batch Plant Operators and Plant Engineers; Gradall; Caisson Rigs; Skimmer Scoop - Koering Scooper; Dredges (all types); Hoptoe; All Cherry Pickers; Work Boat; Ross Carrier; Helicopter; Dozer; Tournadozer; Tournapulls - all and similar types; Operation of Concrete and all Recycle Machines; Multiple Unit Earth Movers; Scoops (all sizes); Pushcats; Endloaders (all types); Asphalt Surfacing Machine; Slip Form Paver; Rock Crusher; Operation of Material Crusher, Screening Plants, and Tunnel Boring Machine; Heavy Equipment Greaser (top greaser on spread); CMI, Auto Grade, CMI Belt Placer & 3 Track and Similar Types; Side Booms; Asphalt Heater & Planer Combination (used to plane streets); Wheel Tractors (with Dozer, Hoe or Endloader Attachments); CAT Earthwork Compactors and Similar Types; Blaw Knox Spreader and Similar Types; Trench Machines; Pump Crete - Belt Crete - Squeeze Crete - Screw Type Pumps and Gypsum (operator will clean); Creter Crane; Operation of Concrete Pump Truck; Formless Finishing Machines; Flaherty Spreader or Similar Types; Screed Man on Laydown Machine; Vermeer Concrete Saw; Operation of Laser Screed; Span Saw; Dredge Leverman; Dredge Engineer; Lull or Similar Type; Hydro-Boom Truck; Operation of Guard Rail Machine; and Starting Engineer on Pipeline or Construction (11 or more pieces) including: Air Compressor (Trailer Mounted), All Forced Air Heaters (regardless of Size), Water Pumps (Greater than 4-1/2" or Total Discharge Over 4-1/2"), Light Plants, Generators (Trailer Mounted - Excluding Decontamination Trailer), Welding Machines (Any Size or Mode of Power), Conveyor, Mixer (any size), Stud Welder, Power Pac, etc, and Ground Heater (Trailer Mounted).

CLASS 2. Bulker & Pump; Power Launches; Boring Machine & Pipe Jacking Machine; Dinkeys; Operation of Carts, Powered Haul Unit for a Boring Machine; P & H One Pass Soil Cement Machines and Similar Types; Wheel Tractors (Industry or Farm Type - Other); Back Fillers; Euclid Loader; Fork Lifts; Jeep w/Ditching Machine or Other Attachments; Tunneluger; Automatic Cement & Gravel Batching Plants; Mobile Drills - Soil Testing and Similar Types; Pugmill with Pump; All (1) and (2) Drum Hoists; Dewatering System; Straw Blower; Hydro-Seeder; Bump Grinders (self-propelled); Assistant Heavy Equipment Greaser; Apsco Spreader; Tractors (Track-Type) without Power Units Pulling Rollers; Rollers on Asphalt - Brick or Macadam; Concrete Breakers; Concrete Spreaders; Cement Strippers; Cement Finishing Machines & CMI Texture & Reel Curing Machines; Vibro-Tampers (All Similar Types Self-Propelled); Mechanical Bull Floats; Self-Propelled Concrete Saws; Truck Mounted Power Saws; Operation of Curb Cutters; Mixers - Over Three (3) Bags; Winch and Boom Trucks; Tractor Pulling Power Blade or Elevating Grader; Porter Rex Rail;

Peoria County Prevailing Wage Rates posted on 3/2/2026

Clary Screed; Mule Pulling Rollers; Pugmill without Pump; Barber Greene or Similar Loaders; Track Type Tractor w/Power Unit attached (minimum); Fireman; Spray Machine on Paving; Curb Machines; Paved Ditch Machine; Power Broom; Self-Propelled Sweepers; Self-Propelled Conveyors; Power Subgrader; Oil Distributor; Straight Tractor; Truck Crane Oiler; Truck Type Oilers; Directional Boring Machine; Horizontal Directional Drill; Articulating End Dump Vehicles; Starting Engineer on Pipeline or Construction (6 -10 pieces) including: Air Compressor (Trailer Mounted), All Forced Air Heaters (regardless of Size), Water Pumps (Greater than 4-1/2" or Total Discharge Over 4-1/2"), Light Plants, Generators (Trailer Mounted - Excluding Decontamination Trailer), Welding Machines (Any Size or Mode of Power), Conveyor, Mixer (any size), Stud Welder, Power Pac, etc., and Ground Heater (Trailer Mounted).

CLASS 3. Straight Framed Truck Mounted Vac Unit (separately powered); Trac Air Machine (without attachments); Rollers - Five Ton and Under on Earth and Gravel; Form Graders; Bulk Cement Plant; Oilers; and Starting Engineer on Pipeline or Construction (3 - 5 pieces) including: Air Compressor (Trailer Mounted), All Forced Air Heaters (regardless of Size), Water Pumps (Greater than 4-1/2" or Total Discharge Over 4-1/2"), Light Plants, Generators (Trailer Mounted - Excluding Decontamination Trailer), Welding Machines (Any Size or Mode of Power), Conveyor, Mixer (any size), Stud Welder, Power Pac, etc., and Ground Heater (Trailer Mounted).

Other Classifications of Work:

For definitions of classifications not otherwise set out, the Department generally has on file such definitions which are available. If a task to be performed is not subject to one of the classifications of pay set out, the Department will upon being contacted state which neighboring county has such a classification and provide such rate, such rate being deemed to exist by reference in this document. If no neighboring county rate applies to the task, the Department shall undertake a special determination, such special determination being then deemed to have existed under this determination. If a project requires these, or any classification not listed, please contact IDOL at 217-782-1710 for wage rates or clarifications.

LANDSCAPING

Landscaping work falls under the existing classifications for laborer, operating engineer and truck driver. The work performed by landscape plantsman and landscape laborer is covered by the existing classification of laborer. The work performed by landscape operators (regardless of equipment used or its size) is covered by the classifications of operating engineer. The work performed by landscape truck drivers (regardless of size of truck driven) is covered by the classifications of truck driver.

Peoria County Prevailing Wage Rates posted on 3/2/2026

Vestibule Repairs - Equipment Service Center

Peoria Park District - Laura Bradley Park

1314 N. Park Rd.

Peoria, IL 61604

Project No. #26-008

Date: 14 April 2026

INDEX OF DRAWINGS:

- G1 - TITLE SHEET
 - A1 - EXISTING PLANS & ELEVATION
 - A2 - EXISTING ELEVATION PICS & NOTES
 - A3 - EXISTING INTERIOR ELEVATION PICS & NOTES
 - A4 - EXTERIOR ELEVATIONS
 - A5 - BUILDING SECTIONS / FRAMING DETAILS
- ORIGINAL 1988 DRAWINGS BY LANKTOIN ZEIGLE & TERRY - FOR REFERENCE ONLY

General Notes:

1. ALL ITEMS SHOWN OR CALLED OUT WITHIN THIS CONSTRUCTION DRAWING SET ARE CONTRACTOR FURNISHED/ CONTRACTOR INSTALLED, UNLESS OTHERWISE NOTED (UON).
2. THE CONTRACTOR SHALL COORDINATE ALL WORK WITH ALL TRADES.
3. CONTRACTOR SHALL BE RESPONSIBLE FOR VISITING SITE, TO VERIFY ALL EXISTING CONDITIONS, DIMENSIONS, & QUANTITIES PRIOR TO BIDDING. ANY DISCREPANCIES BETWEEN THESE DRAWINGS AND THOSE CONDITIONS SHALL BE PRESENTED TO THE OWNER'S REPRESENTATIVE IN WRITING PRIOR TO BIDDING.
4. ITEMS INDICATED TO BE REMOVED SHALL BE DONE SO IN THEIR ENTIRETY. ALL RELATED APPURTENANCES SHALL BE REMOVED TO ACCOMMODATE INSTALLATION OF NEW WORK. ALL DEMOLITION SHALL BE CAREFULLY COORDINATED WITH REQUIREMENTS OF NEW WORK.
5. AT ANY TIME DURING CONSTRUCTION, ANY EVIDENCE OF STRUCTURAL DAMAGE, SUCH AS DETERIORATION OF ROOF DECK, ANGLES, JOISTS, BEAMS, ETC. ARE TO BE BROUGHT TO THE ATTENTION OF A/E, UNLESS IT IS WORK INCLUDED HEREIN.
6. CONTRACTOR SHALL MEET ALL CODE REQUIREMENTS DURING CONSTRUCTION.
7. THE CONTRACTOR SHALL BE RESPONSIBLE FOR REPAIRING ANY DAMAGED/DISTURBED EXISTING GRASS/LAWN AREAS, PAVEMENT OR CONCRETE. THE GRASS AREAS SHALL BE RE-GRADED, SEED, FERTILIZED, COVERED WITH STRAW AND NEW TOPSOIL AS NEEDED TO ACHIEVE THE LOOK PRIOR TO DAMAGE. ANY CONCRETE WALKS, PAVEMENT, AND CURBS DAMAGED DURING CONSTRUCTION SHALL BE SAW-OUT AND REPLACED IN SECTIONS TO MATCH EXISTING PRIOR TO DAMAGE.

PROJECT LOCATION

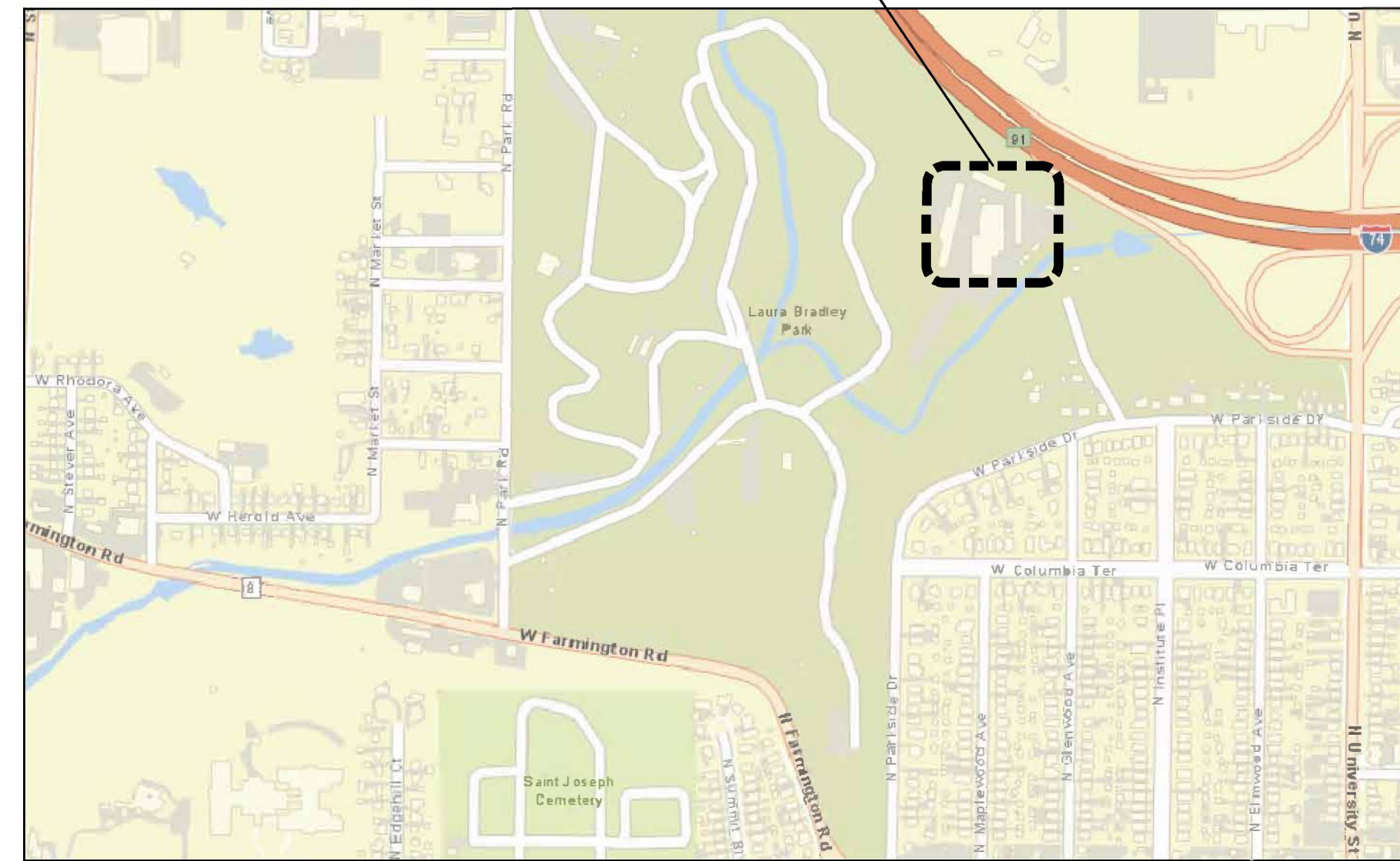

LOCATION IN CITY

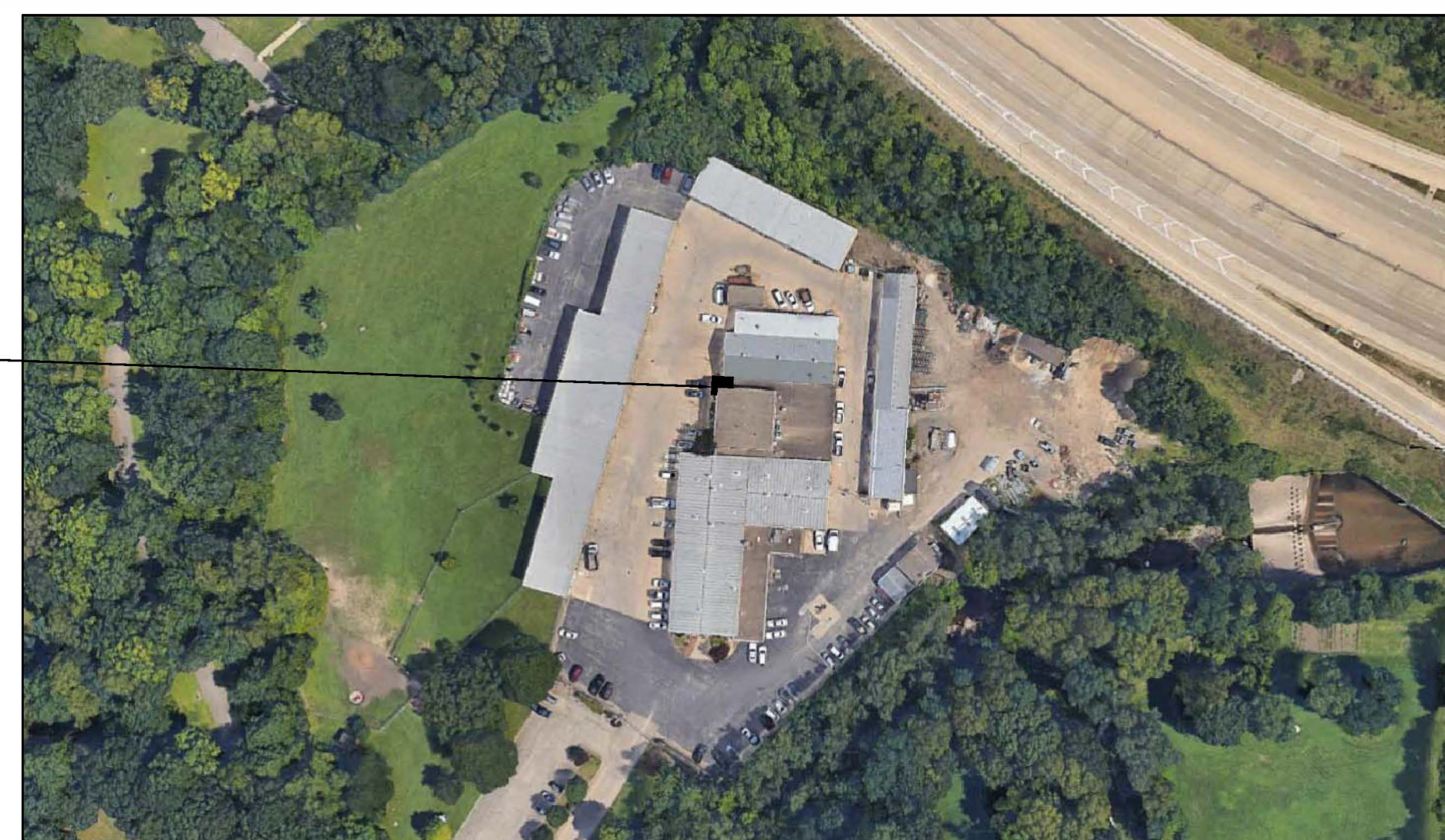
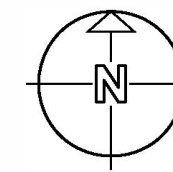

AREA OF ROOF WORK SHOWN SHADED

Key Plan

NO SCALE

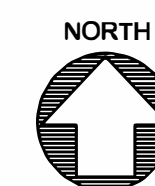

ABBREVIATIONS:

A.D.A.	AMERICANS WITH DISABILITIES ACT	L.F.	LINEAR FEET
A.F.F.	ABOVE FINISHED FLOOR	MANUF.	MANUFACTURE (R)
ALT.	ALTERNATE	MAS.	MASONRY
ALUM.	ALUMINUM	MAX.	MAXIMUM
APPROX.	APPROXIMATE	M.B.	MARKER BOARD
ARCH.	ARCHITECT (URAL)	MECH.	MECHANICAL
BRNG.	BEARING	MIN.	MINIMUM
B.O.	BY OWNER	MISC.	MISCELLANEOUS
C.	CENTER LINE	MTL.; MET.	METAL
C/C	CENTER-TO-CENTER	MNTD.	MOUNTED
C.G.	CORNER GUARD	No.	NUMBER
C.R.	CLASSROOM	N.I.C.	NOT IN CONTRACT
CLNG.	CEILING	O.C.	ON CENTER
CLR.	CLEAR (ANCE)	OPNG.	OPENING
C.M.U.	CONCRETE MASONRY UNIT	OPP.	OPPOSITE
COL(S)	COLUMN (S)	O.D.	OUTSIDE DIAMETER
COMP.	COMPRESSED; COMPACTED	O.S.B.	ORIENTED STRAND BOARD
CONC.	CONCRETE	P.LAM.	PLASTIC LAMINATE
CONSTR.	CONSTRUCTION	PLYWD.	PLYWOOD
CONT.	CONTINUE (OUS)	PNT., PT.	PAINT
COORD.	COORDINATE	P.C.	PORTLAND CEMENT
CPT.	CARPET	RAD.	RADIUS
C.T.	CERAMIC TILE	REINF.	REINFORCE (D); (ING)
DBL.	DOUBLE	REQD.	REQUIRED
DP.	DEEP	REF.	REFERENCE
DEMO.	DEMOLITION	R.B.	RESILIENT BASE
DET.	DETAIL	RM.	ROOM
DIA.	DIAMETER	R.T.U.	ROOF-TOP UNIT
DR. (S)	DOOR (S)	SCHED.	SCHEDULE (D)
D.S.	DOWNSPOUT	SLNT.	SEALANT
DN.	DOWN	S.F.	SQUARE FEET
EA.	EACH	SHT.	SHEET
E.F.	EXHAUST FAN	SIM.	SIMILAR
E.I.F.S.	EXTERIOR INSULATION FINISH SYSTEM	S.C.WD.	SOLID-CORE WOOD
ELEC.	ELECTRICAL	SPEC.	SPECIFICATION (S)
EL.; ELEV. (S)	ELEVATION (S)	SQ.	SQUARE
EQ.	EQUAL	S.STL.	STAINLESS-STEEL
EQUIP.	EQUIPMENT	STL.	STEEL
EXIST.	EXISTING	STOR.	STORAGE
EXT.	EXTERIOR	STRUCT.	STRUCTURAL
F.B.	FACE-BRICK	SUSP.	SUSPENDED
F.D.	FLOOR DRAIN; FILE DRAWER	T.	TALL
FDN.	FOUNDATION	T.G.	TONGUE-AND-GROOVE
F.E.C.	FIRE EXTINGUISHER CABINET	T.B.	TACK BOARD
FIN.	FINISHED (ED)	T.B.R.	TO BE REMOVED
FLR. (NG)	FLOOR (ING)	THK.	THICK (NESS)
F.R.P.	FIBERGLASS RE-INFORCED PANEL	T.O.	TOP OF
FTG.	FOOTING	TYP.	TYPICAL
GA.	GAUGE	U.O.N.	UNLESS OTHERWISE NOTED
GALV.	GALVANIZED	V.B.	VINYL BASE
G.B.	GYPSON BOARD	V.C.T.	VINYL COMPOSITION TILE
GL.	GLASS; GLAZING	VERT.	VERTICAL
GYP.	GYPSON	VEST.	VESTIBULE
H.	HIGH	W.C.	WALL COVERING
HGT.	HEIGHT	W.W.F.	WELDED WIRE FABRIC
HR.	HOUR	W.	WIDTH
HORIZ.	HORIZONTAL	W/	WITH
H.M.	HOLLOW METAL	WIN. (S)	WINDOW (S)
JNT.	JOINT	W/O	WITHOUT
INSUL.	INSULATION	WD.	WOOD
L.	LENGTH		

ARCHITECTURAL LEGEND:

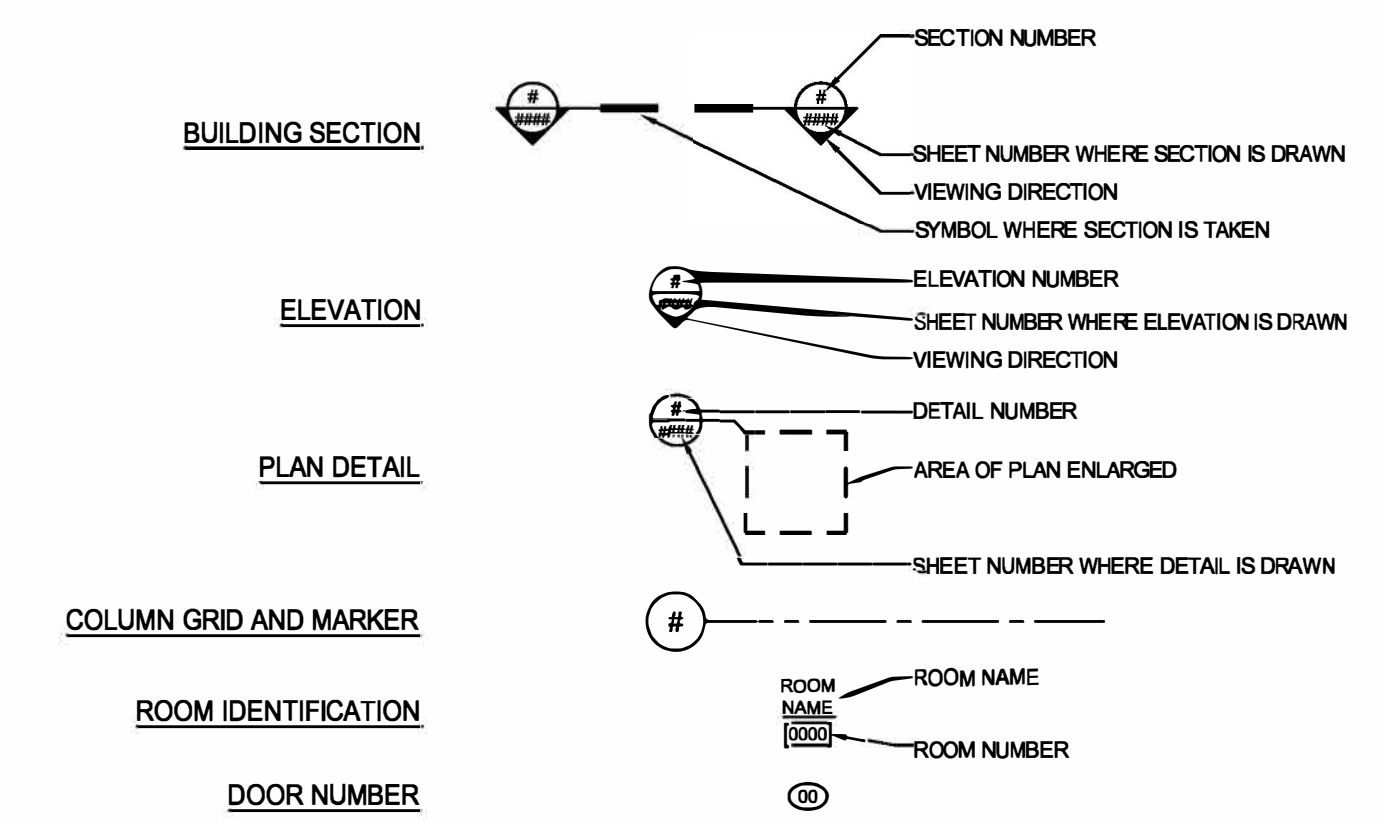

MATERIAL DESIGNATIONS:

	CONCRETE		ROUGH WOOD (DISCONTINUOUS)
	SAND OR GROUT		ROUGH WOOD (CONTINUOUS)
	GRAVEL FILL		CONCRETE MASONRY UNITS (CMU)
	INSULATION (RIGID)		FACE BRICK
	INSULATION (BATT.)		

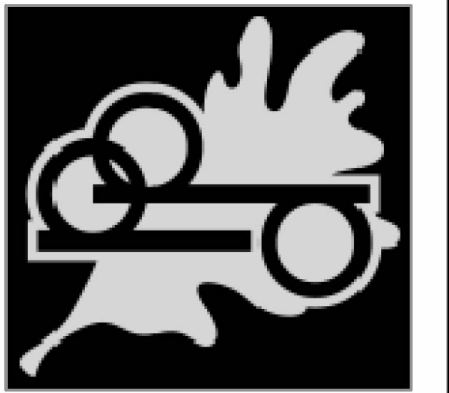

Peoria Park District
Equipment Service Center
Vestibule Repairs -
Peoria, IL 61604

TITLE SHEET

NO.	ISSUE	DATE
1	Bid Docs	4.14.26

DATE: 04.14.26 PROJECT NO: 26-008

SHEET **G1**
1 OF 1

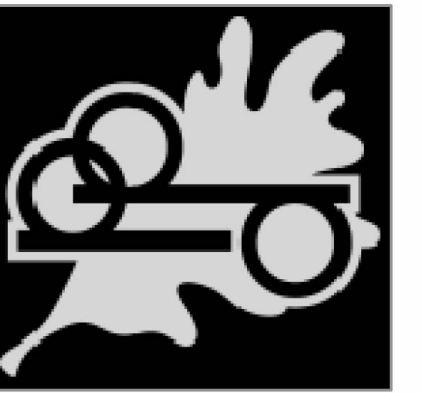

EXISTING ELEVATION PICS & NOTES
Vestibule Repairs - Equipment Service Center
 Peoria Park District
 Peoria, IL 61604

NO.	ISSUE	DATE
1	Bid Documents	04.14.26

DATE: 04.14.26 PROJECT NO: 26-008

SHEET

A2

2 OF 3



CAREFULLY REMOVE EXISTING METAL DRIP/FASCIA FOR REPLACEMENT OF HORIZONTAL BEAM. STANDING SEAM ROOF AND RELATED ROOFING METAL IS STILL UNDER WARRANTY AND ALL REPAIR AND REMOVAL BY KREILING ROOFING AS PART OF THIS WORK & INCLUDED IN CONTRACTOR'S BID.

CAREFULLY REMOVE EXISTING 6x6 CEDAR POSTS & 6x6 HORIZONTAL BEAMS/MEMBERS FOR REPLACEMENT WITH NEW CEDAR WOOD POSTS AND BEAMS TO MATCH. REMOVE POSTS AND BEAMS IN A SEQUENCE ALLOWING 1 REPLACEMENT AT A TIME WHILE PROVIDING SHORING OF ADJACENT CONSTRUCTION AND CEDAR MEMBERS. RE-USE EXIST. STEEL PLATE CONNECTORS. PREPARE, PRIME & FINISH PAINT EACH CONNECTOR. BOLTS SHALL NOT BE RE-USED AT TIMBERS. PROVIDE NEW GALVANIZED THRU-BOLTS, WASHERS & NUTS MATCHING DIAMETER & LENGTH, TYP.

CAREFULLY & TEMPORARILY REMOVE EXISTING METAL SIDING END J-TRIM AND METAL SIDING FOR REMOVAL AND INSTALL OF NEW 6x6 CEDAR POST. T111 SIDING IS BENEATH METAL PANEL AND NAILS SHALL BE REQUIRED TO BE REMOVED FROM SIDING TO CEDAR POST. RE-FASTEN T111 SIDING AND METAL WALL PANELS WHEN COMPLETE. PROVIDE NEW SIDING NEOPRENE GASKETED FASTENERS TO MATCH

CAREFULLY REMOVE EXISTING METAL DRIP/FASCIA FOR REPLACEMENT OF HORIZONTAL BEAM. STANDING SEAM ROOF AND RELATED ROOFING METAL IS STILL UNDER WARRANTY AND ALL REPAIR AND REMOVAL BY KREILING ROOFING AS PART OF THIS WORK & INCLUDED IN CONTRACTOR'S BID.

REMOVE & PROVIDE NEW COUNTERFLASHING AS REQUIRED FOR CEDAR POST REMOVAL & INSTALL OF NEW.

TEMPORARILY REMOVE DOWNSPOUT AND GUTTER DURING CEDAR POST AND BEAM REPLACEMENTS.

CAREFULLY REMOVE EXISTING INSULATED GLAZING AND SAVE FOR REINSTALLATION. REINSTALL AT EACH NEW CEDAR POST W/ NEW STAINLESS EXPANSION ANCHORS AND NEW STAINLESS LAG BOLTS TO MATCH.

NOTE: PROVIDE 3/4" PLYWOOD INFILL PANELS AT REMOVED GLASS PANELS AT END OF EACH WORK DAY AND AT END OF THE WORK SO THE VESTIBULE / BUILDING ARE SECURE DURING NON WORK DAYS.

PROVIDE ALL NEW STAINLESS STEEL BOLTS TO MATCH DIAMETER & LENGTH W/ STAINLESS WASHER, TYPICAL.

TEMPORARILY REMOVE EXISTING STEEL DOOR AND FRAME FOR REPLACEMENT OF ADJACENT 2x WD. CEDAR JAMBS. REINSTALL WHEN WOOD IS REPLACED. PROVIDE NEW PEMKO OR NATIONAL DOOR SWEEP.



2 EXISTING ENTRY ELEVATION LOOKING SOUTHEAST

A2 NOT TO SCALE



CAREFULLY REMOVE EXISTING INSULATED GLAZING AND SAVE FOR REINSTALLATION.

PROVIDE NEW CEDAR WOOD GLAZING STOPS TO MATCH EXISTING, TYPICAL

PROVIDE GLAZING SEALANT AT ALL NEWLY INSTALLED WOOD STOPS AND REINSTALLED GLAZING, TYPICAL

REMOVE (E) STAINLESS STEEL SURFACE BRACKETS, TURN OVER TO OWNER. PROVIDE NEW SIMPSON STRONG TIE 6X6 ABU66Z POST BASE AT EACH POST. EPOXY ANCHOR TO CONCRETE BASE WITH 5/8" HILTI TYPE EXPANSION ANCHORS, TYP. @ EA. POST. PATCH REMAINING HOLES IN CONCRETE FROM ANCHORS WITH SIKA BRAND EPOXY PATCHING CONCRETE.

PROVIDE 4X6 CEDAR BASE BETWEEN POSTS, TYP. OVER STEEL PLATE. SEE ALSO NOTES ON 2/A1.

FLASHING TAPE & SEALANT BETWEEN WOOD, STEEL & CONCRETE. CONT., TYP. SEE ALSO NOTES ON 2/A1.

PROVIDE NEW 4"x8" CEDAR BASE / SILLS TO MATCH EXIST. RE-USE CLIP ANGLES/ ANCHORS TO EXISTL FOUNDATION. PREPARE, PRIME & PAINT CLIP ANGLES. PROVIDE NEW GALVANIZED THRU-BOLTS SET NEW 4x6 CEDAR SILL ON ASPHALT IMPREGNATED WINDOW & DOOR JAMB FLASHING TAPE & 3 1/2" WIDE 3/16" THK x 3-1/2" WIDE STEEL PLATE.

3 EXISTING TYPICAL POST CONNECTION @ FDN.

A2 NOT TO SCALE

1 EXISTING ENTRY ELEVATION LOOKING NORTHEAST

A2 NOT TO SCALE



EXISTING INTERIOR ELEVATION PICS & NOTES
Vestibule Repairs - Equipment Service Center
 Peoria Park District
 Peoria, IL 61604



- REPLACE CEDAR 2X JAMBS AT STL. DR. FRAME
- CEDAR HORIZONTAL ABOVE TO REMAIN / REUSE. SHORE UP AS REQUIRED.
- EXIST. CEDAR POST AT MASONRY WALL SHALL REMAIN / RE-USE.
- PREPARE, PRIME & FINISH PAINT STEEL DOOR & FRAME.

1 EXISTING INTERIOR ELEV. LOOKING SOUTHWEST
 A3 NOT TO SCALE



- CAREFULLY REMOVE EXISTING 6x6 CEDAR POSTS & 6x6 HORIZONTAL BEAMS/MEMBERS FOR REPLACEMENT WITH NEW CEDAR WOOD POSTS AND BEAMS TO MATCH REMOVE POSTS AND BEAMS IN A SEQUENCE ALLOWING 1 REPLACEMENT AT A TIME WHILE PROVIDING SHORING OF ADJACENT CONSTRUCTION AND CEDAR MEMBERS. RE-USE EXIST. STEEL PLATE CONNECTORS. PREPARE, PRIME & FINISH PAINT EACH CONNECTOR. BOLTS SHALL NOT BE RE-USED AT TIMBERS. PROVIDE NEW GALVANIZED THRU-BOLTS, WASHERS & NUTS MATCHING DIAMETER & LENGTH, TYP.
- PROVIDE NEW INTERIOR CEDAR STOPS TO MATCH EXISTING-TYP.

3 EXISTING INTERIOR ELEV. LOOKING WEST
 A3 NOT TO SCALE

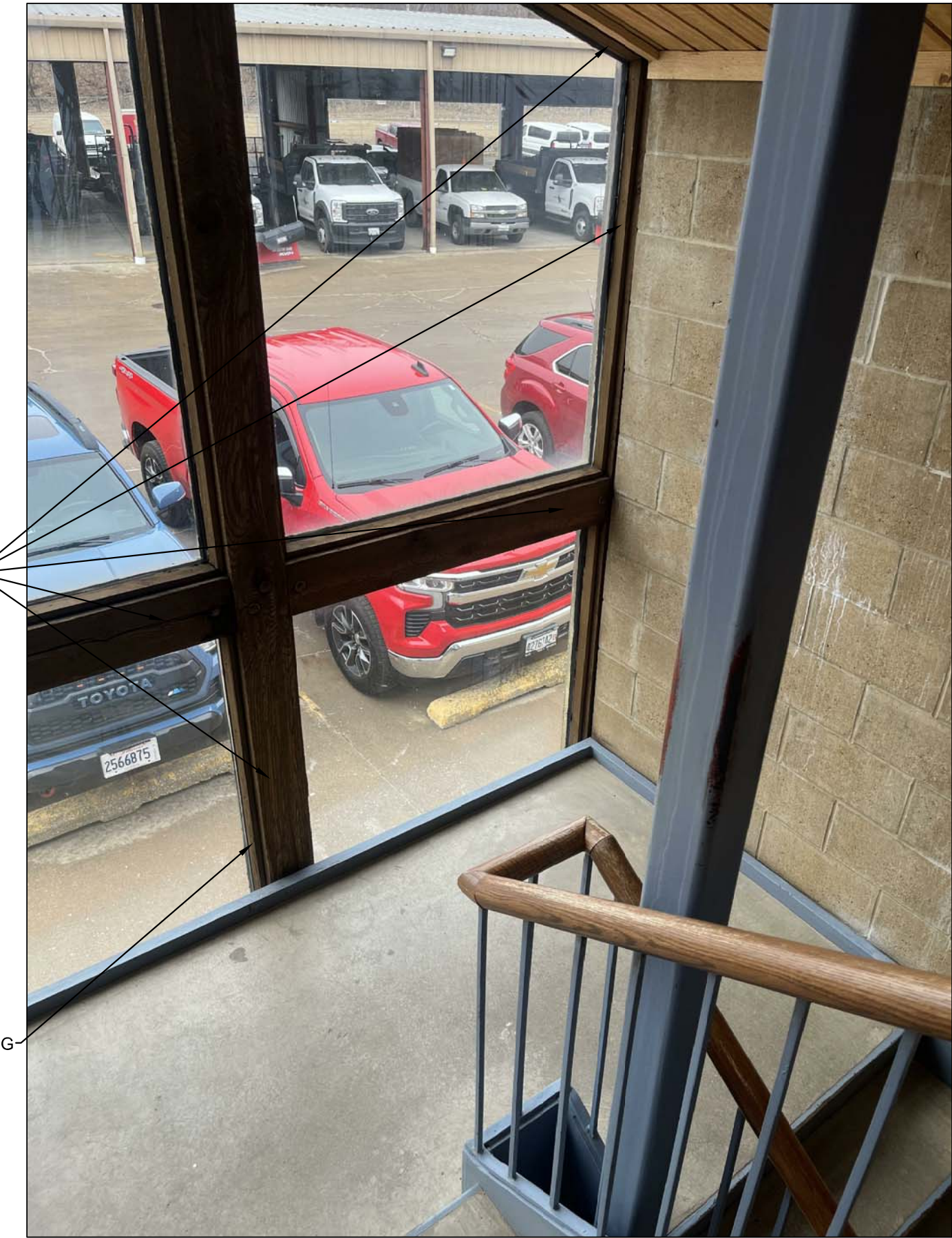

5 EXISTING INTERIOR ELEV. LOOKING NORTH
 A3 NOT TO SCALE

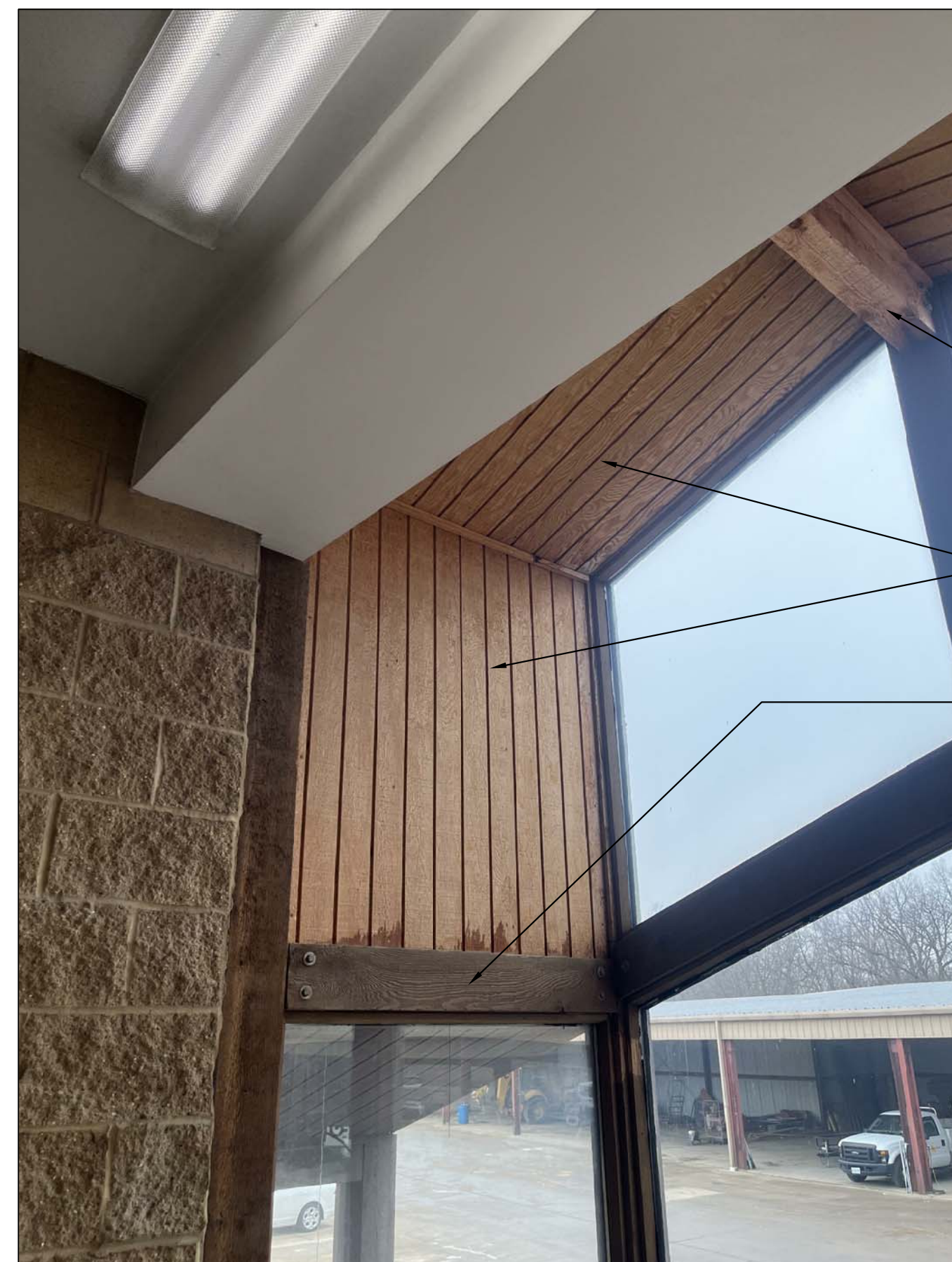

- CEDAR RIDGE BEAM TO REMAIN / REUSE SHORE UP AS NECESSARY FOR POST REMOVAL & REPLACEMENT.
- REMOVE ANY EXIST. T-111 PLYWOOD AS REQUIRED FOR HORIZ. & VERTICAL POST REPLACEMENT PROVIDE NEW
- CEDAR HORIZONTAL ABOVE TO REMAIN / REUSE. SHORE UP AS REQUIRED.

2 EXISTING INTERIOR ELEV. LOOKING SOUTHWEST
 A3 NOT TO SCALE



4 EXISTING INTERIOR ELEV. LOOKING NORTHWEST
 A3 NOT TO SCALE

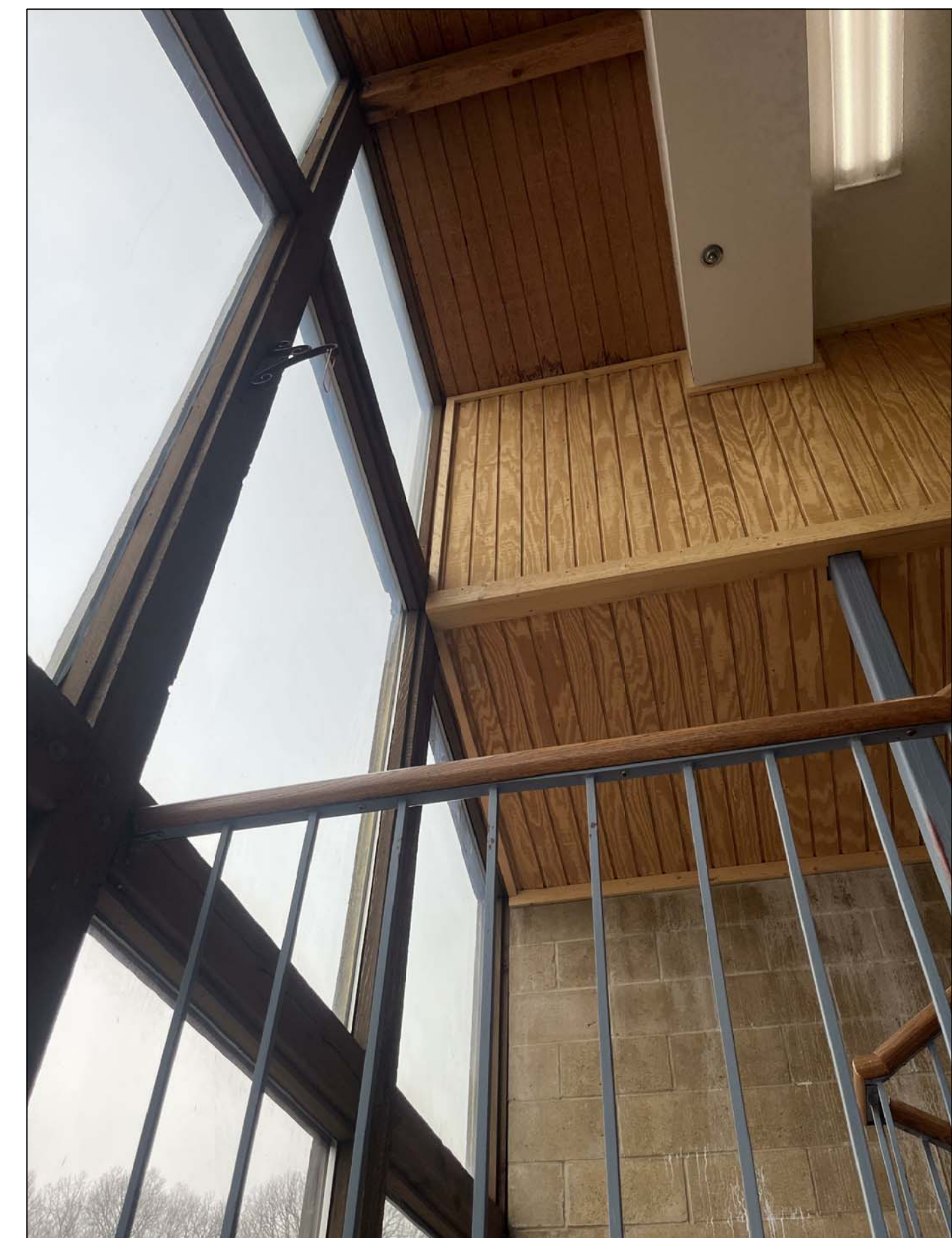

6 EXISTING INTERIOR ELEV. LOOKING NORTH
 A3 NOT TO SCALE

NO.	ISSUE	DATE
1	Bid Documents	04.07.26

DATE	PROJECT NO.
04.07.26	26-008

DRI @ 1/8" = 1'-0"

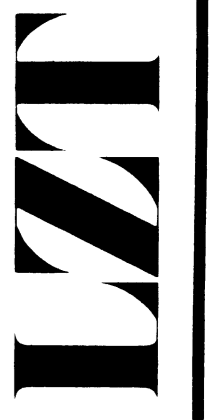

Sheet No.

Date

EQUIPMENT MAINTENANCE FACILITY
BRADLEY PARK, PEORIA, ILLINOIS
for PLEASURE DRIVEWAY AND PARK DISTRICT OF PEORIA

Checked By

Drawn By

Revised

Sheet No.

A4

Job No.

187055

Date

6-24-88

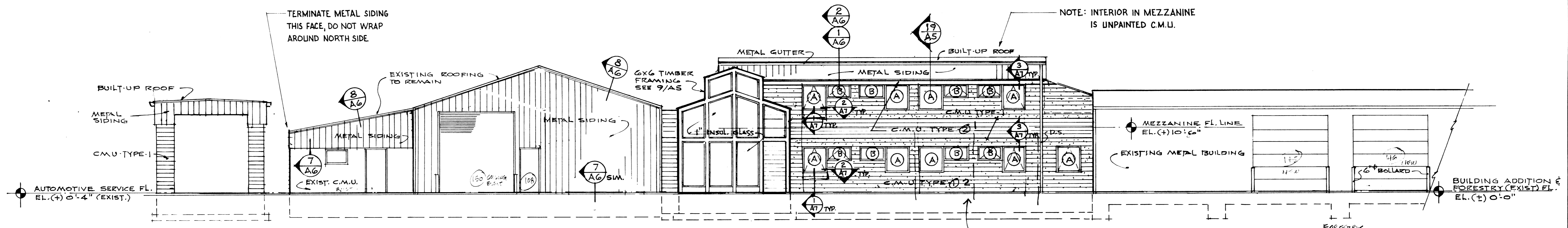

20 WEST ELEVATION
SCALE: 1/8" = 1'-0"

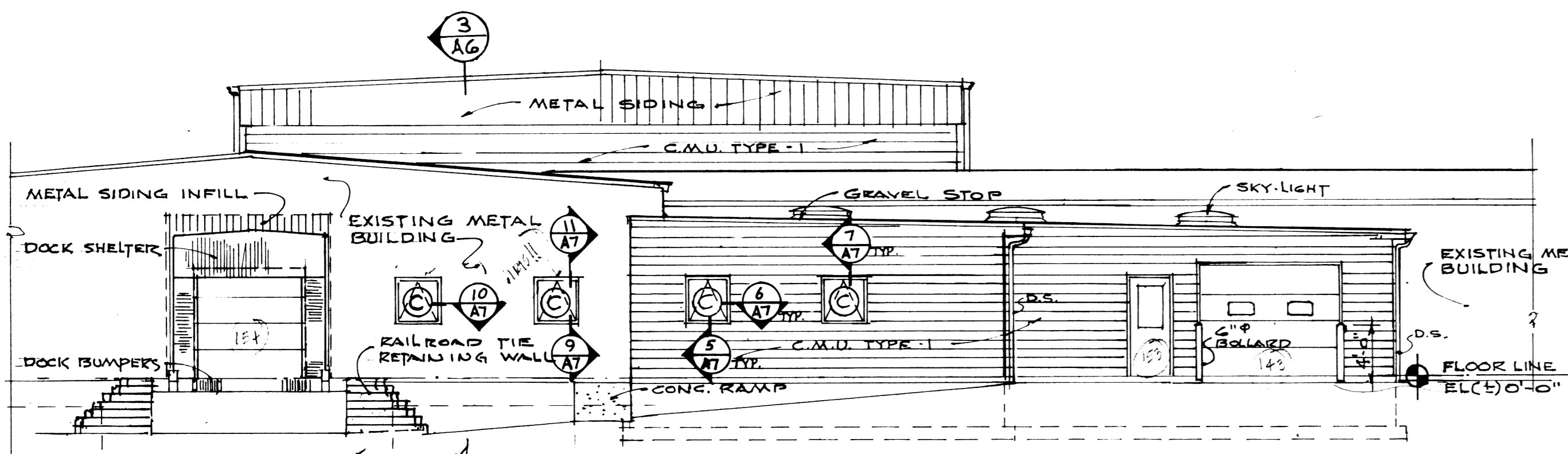

15 SOUTH ELEVATION
SCALE: 1/8" = 1'-0"

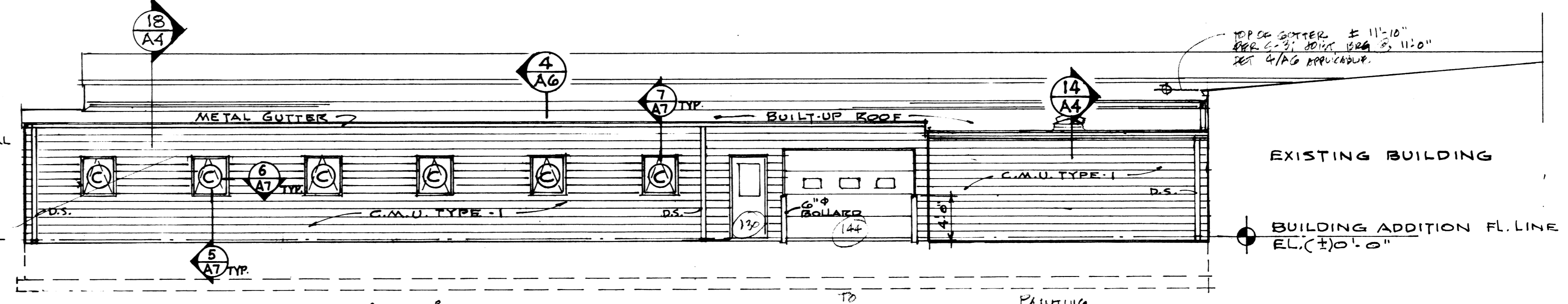

11 PARTIAL EAST ELEVATION
SCALE: 1/8" = 1'-0"

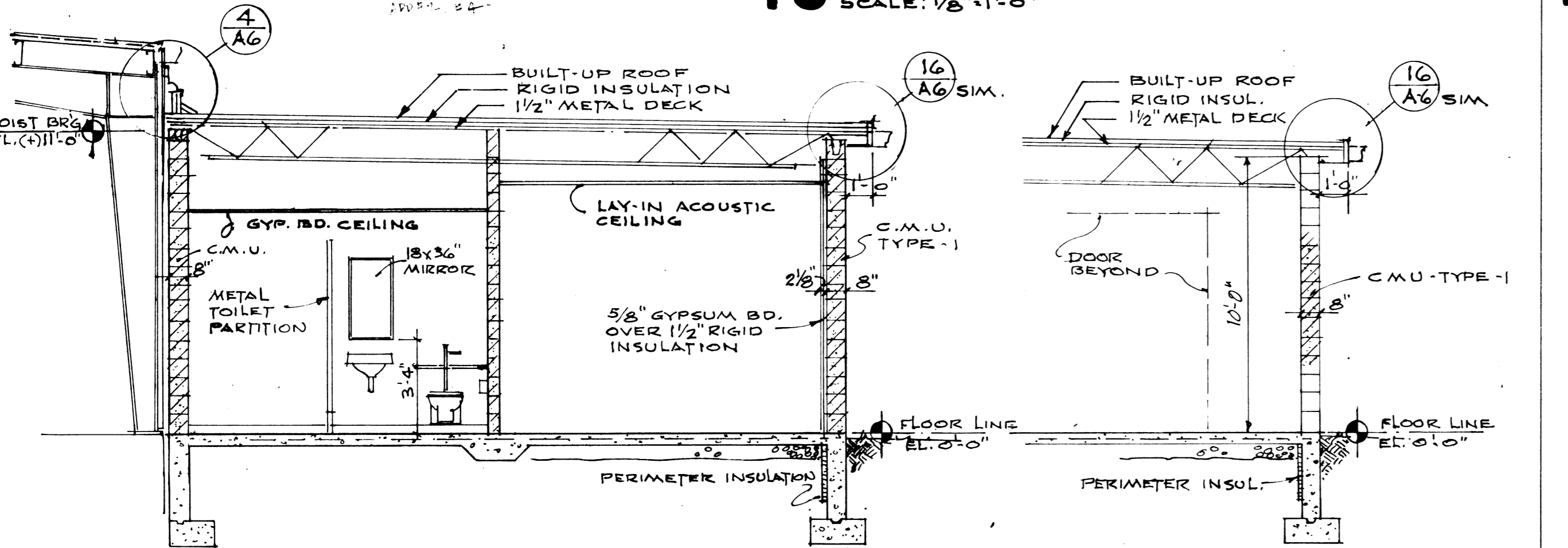

18 SECTION
SCALE: 1/4" = 1'-0"

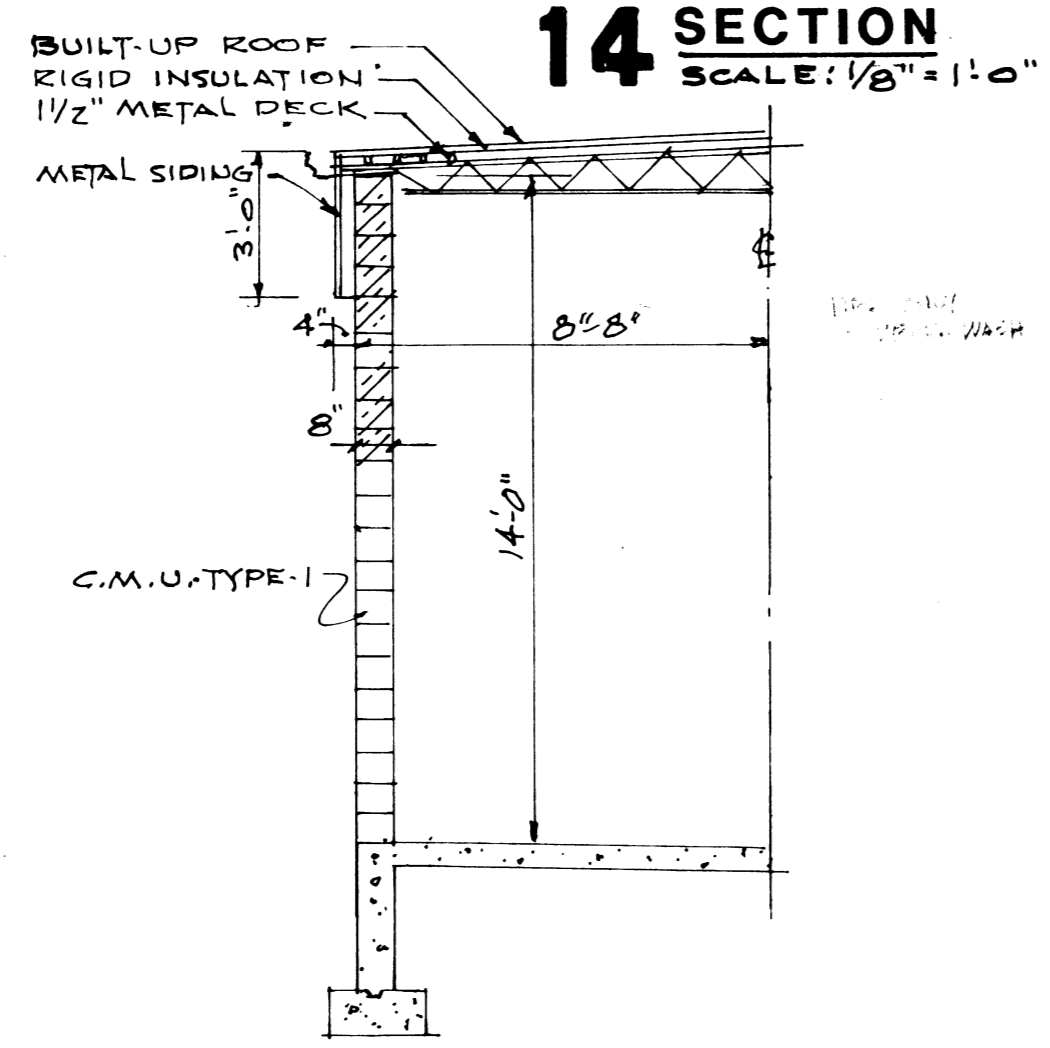

14 SECTION
SCALE: 1/8" = 1'-0"

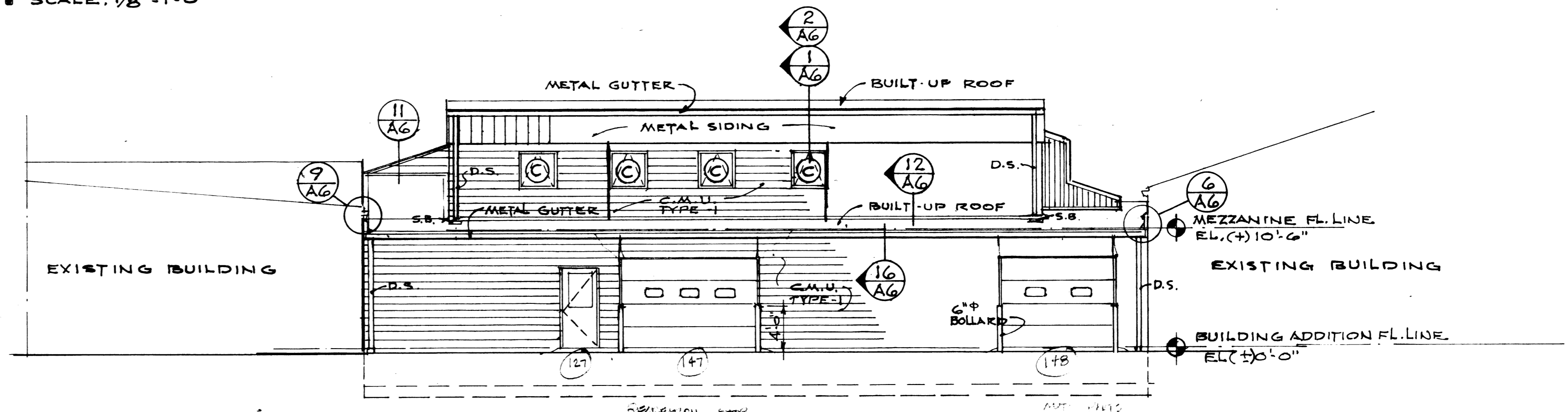

6 PARTIAL EAST ELEVATION
SCALE: 1/8" = 1'-0"

TOILET ROOM ACCESSORIES

- ALL LAVATORIES SHALL HAVE AN 18" X 36" MIRROR MOUNTED ABOVE 3'-4" FROM THE FLOOR, AS SHOWN ON SECTION 18, SHEET A4.
- GRAB BARS SHALL BE INSTALLED IN TOILET ROOMS 111 AND 115. DIMENSIONS SHALL BE 2'-0" LONG BEHIND THE WATERCLOSET AND 3'-6" LONG ALONG ADJACENT WALL MOUNTED 2'-10" ABOVE THE FLOOR AT THE CENTERLINE.
- EACH WATERCLOSET STALL SHALL BE PROVIDED WITH A TOILET PAPER HOLDER AS SPECIFIED, MOUNTED 1'-8" ABOVE THE FLOOR AT CENTERLINE.
- EACH TOILET ROOM SHALL HAVE A PAPER TOWEL DISPENSER AND SOAP DISPENSER MOUNTED CLOSE TO THE LAVATORY(S) AS SPECIFIED. MOUNT THE SOAP DISPENSER 3'-4" ABOVE FLOOR AT THE BOTTOM. MOUNT THE TOWEL DISPENSER 4'-0" ABOVE FLOOR.

4. Drawing Sheet A4, South Elevation 15:

- Existing foundation and footing conditions are unknown. Grade is being dropped 4'-0" to create a Loading Dock.
- A detail of a supplemental wall and underpinning requirements will be issued following careful excavation to determine the existing conditions and prior to construction of this dock.
- For bidding purposes assume that a new reinforced concrete wall will be provided in contact with and dowelled into the existing foundation. It will be a minimum of 8" thick x 12'-0" long x 7'-0" deep.

WINDOW SCHEDULE & QUALITY STANDARD

ALL WINDOWS SHOWN ARE MANUFACTURED BY THE ANDERSEN CORPORATION, BAYPORT, MINNESOTA.

TYPE "A" - PERMA-SHIELD VENTING AWNING WINDOW AP42-T.

TYPE "B" - PERMA-SHIELD AWNING WINDOW A41-T.

TYPE "C" - PERMA-SHIELD AWNING WINDOW A335-T.

CONCRETE FACING BLOCK (DECORATIVE MASONRY UNITS)

TYPE 1 - 8" X 16" SMOOTH SURFACE - INTEGRALLY COLORED.

TYPE 2 - 8" X 16" "SPLIT" OR "ROCK" FACE - INTEGRALLY COLORED.

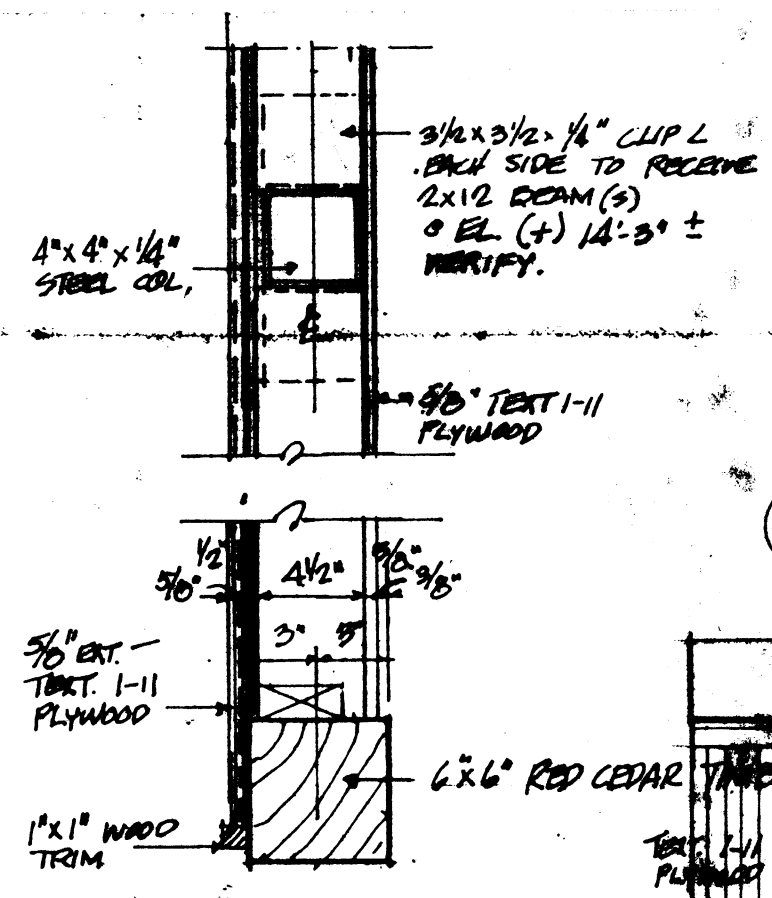

DETAIL 20 PLAN VIEW
SCALE 1/2" = 1'-0"

SECTION 19
SCALE 1/4" = 1'-0"

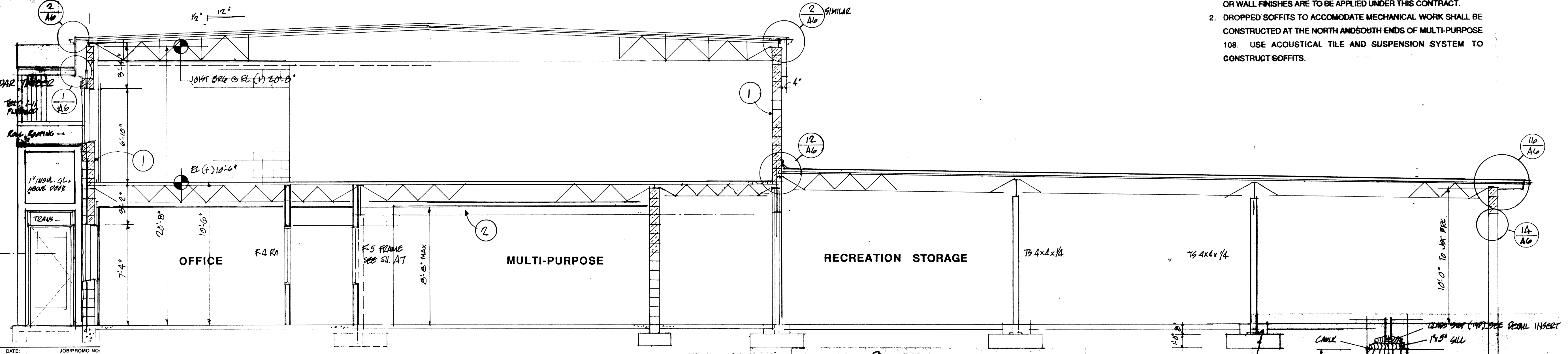

JOB/PROJECT NAME: EQUIPMENT MAINTENANCE FACILITY
DATE: 11/19/88
JOB/PROJECT NO.: 187055

JOB/PROJECT NAME: EQUIPMENT MAINTENANCE FACILITY
DATE: 11/19/88
JOB/PROJECT NO.: 187055

TITLE: DETAIL 18 & BEAM BEARING DETAIL
PAGE NO.: 2 OF 2

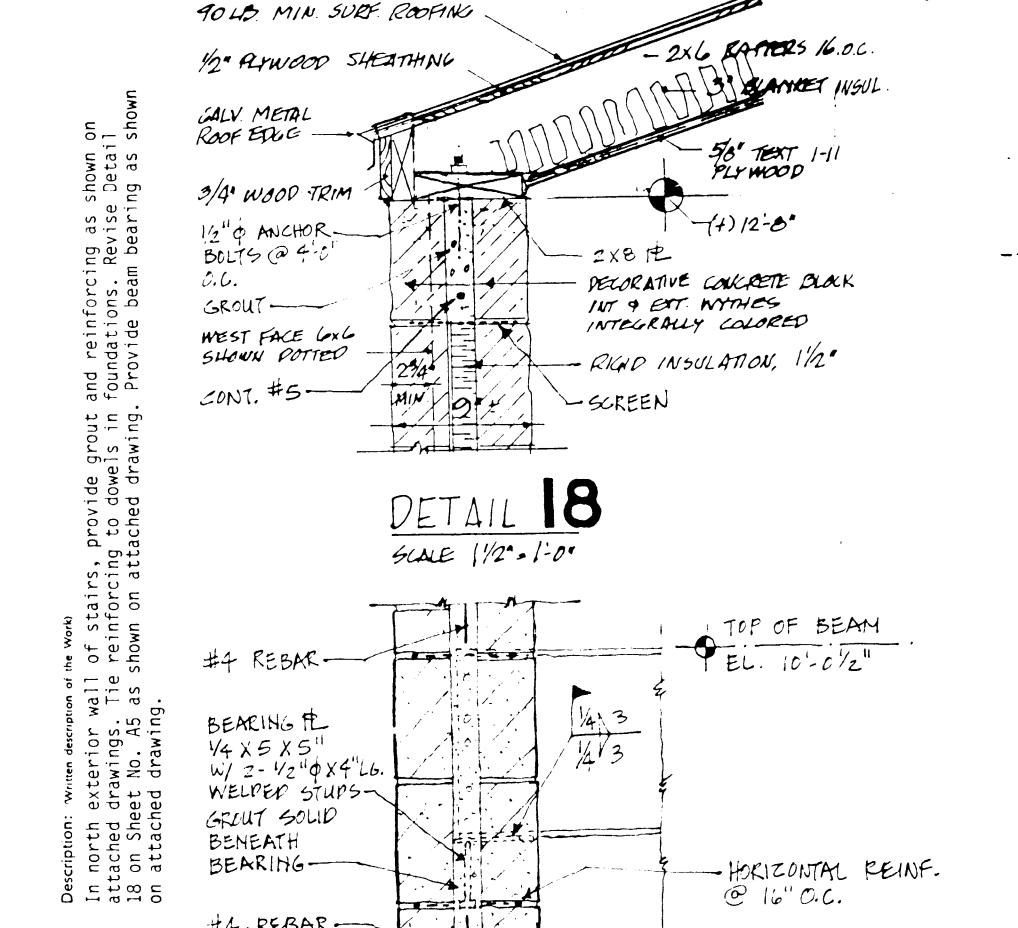

DETAIL 18
SCALE 1/2" = 1'-0"

BEAM BEARING DETAIL
SCALE 1/2" = 1'-0"

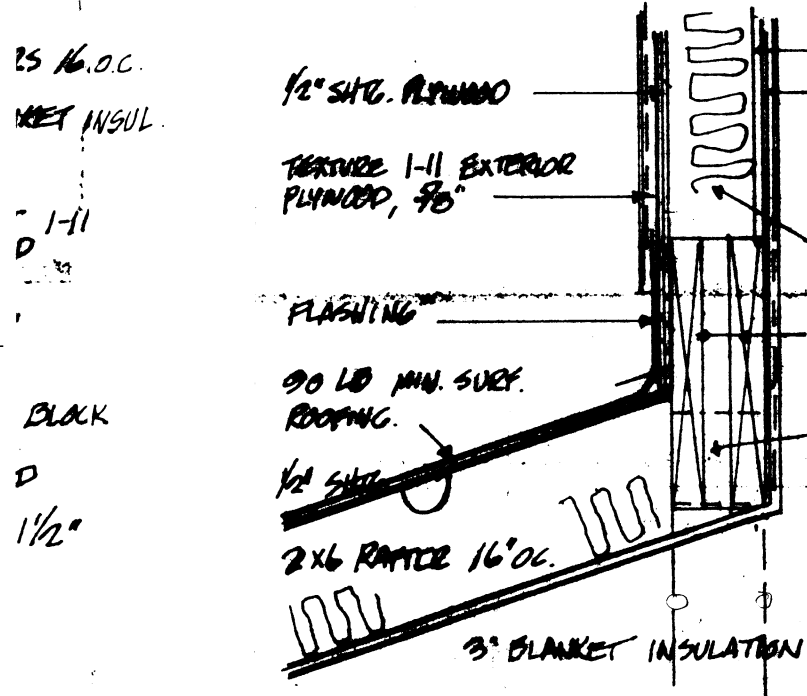

DETAIL 14
SCALE 1/2" = 1'-0"

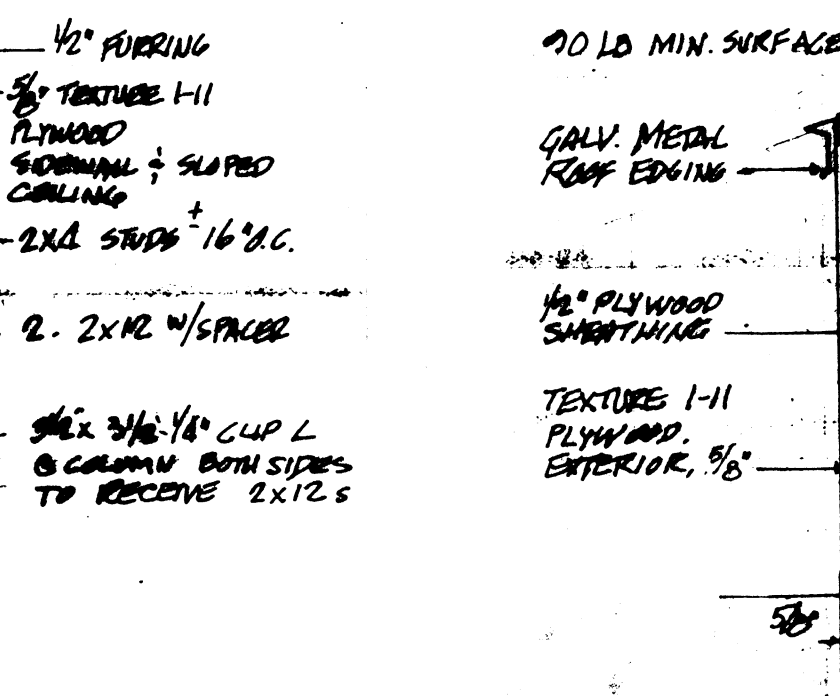

DETAIL 10
SCALE 1/2" = 1'-0"

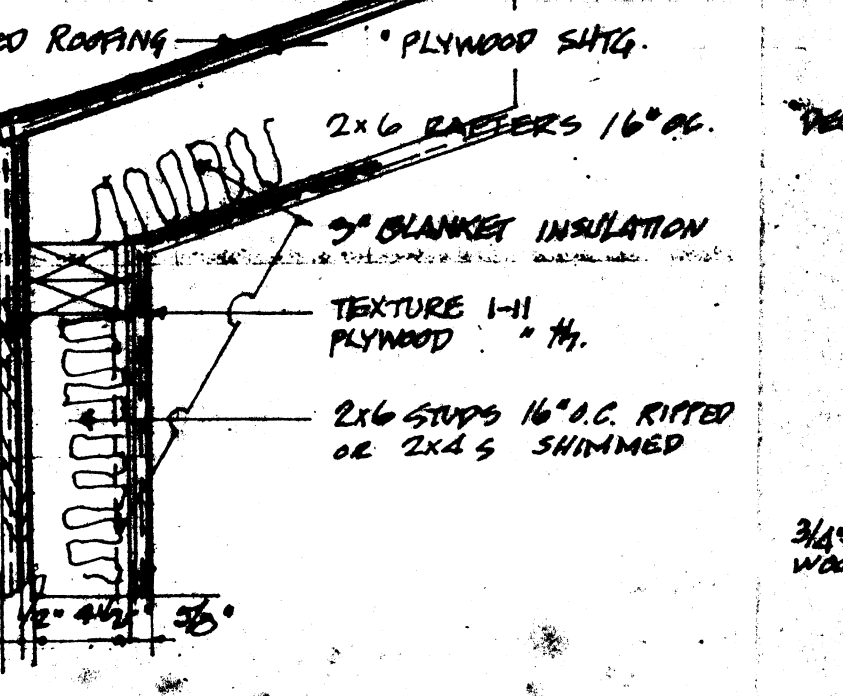

DETAIL 6
SCALE 1/2" = 1'-0"

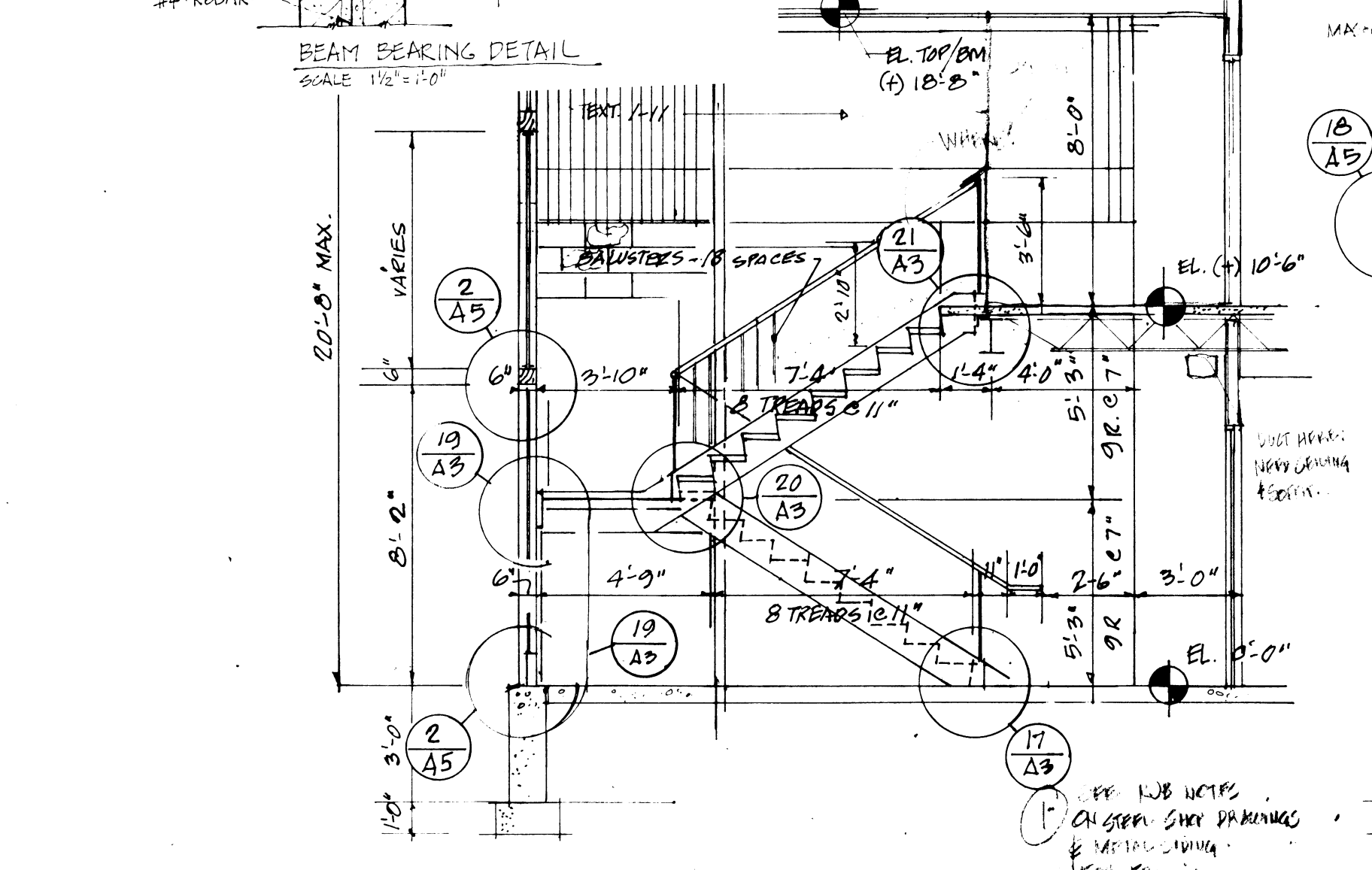

SECTION 17 SCALE 1/4" = 1'-0"

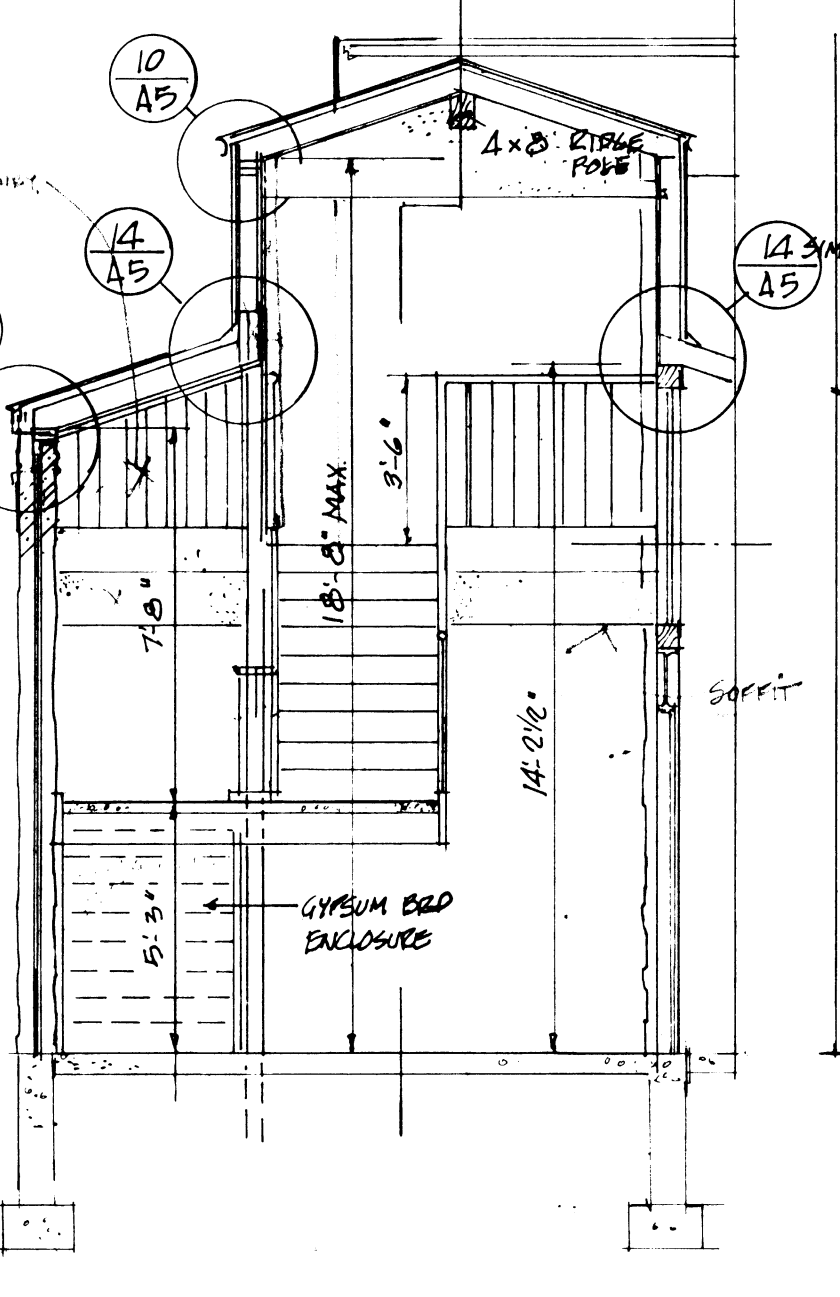

SECTION 13 SCALE 1/4" = 1'-0"

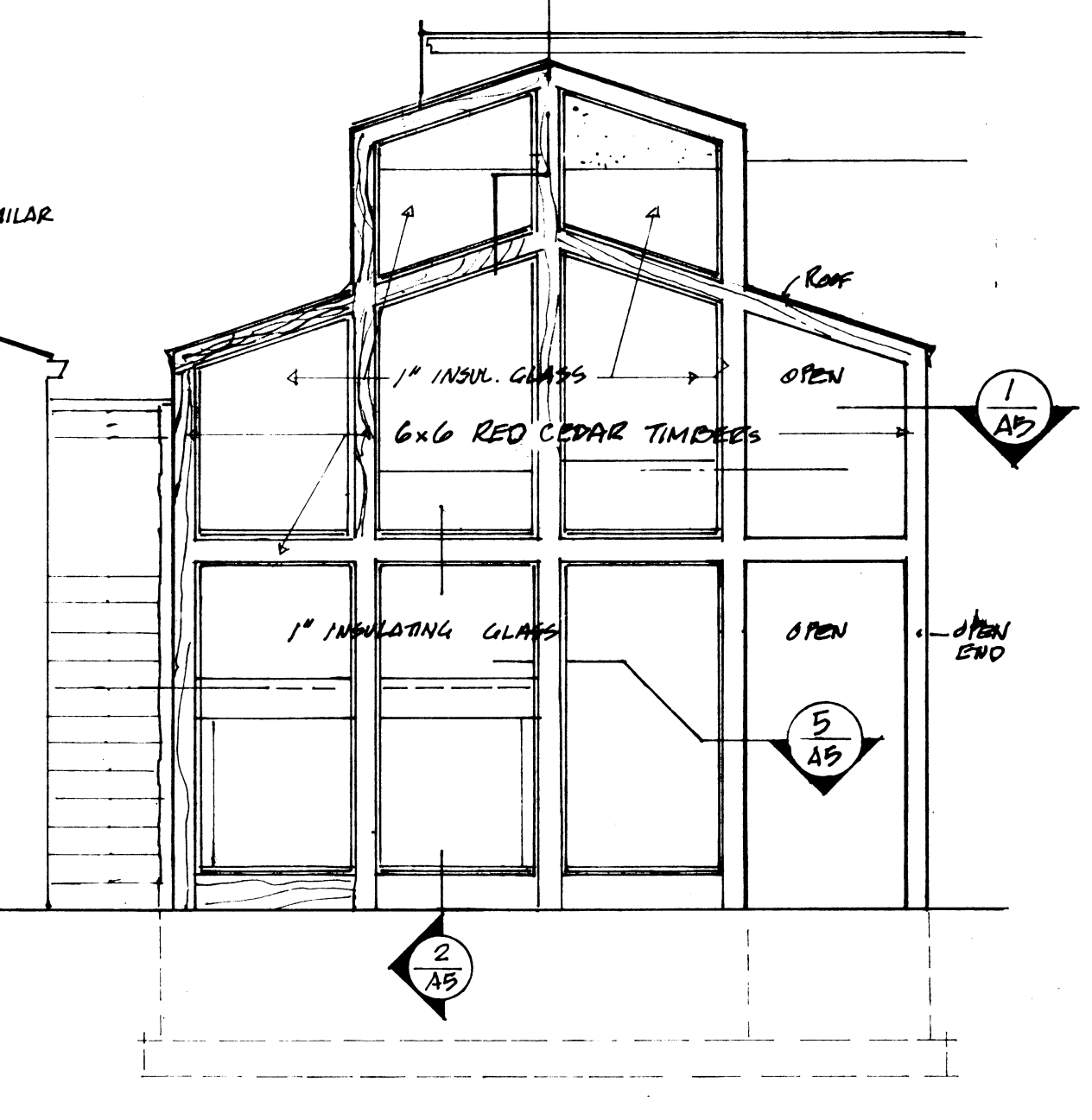

ELEVATION 9 SCALE 1/4" = 1'-0"

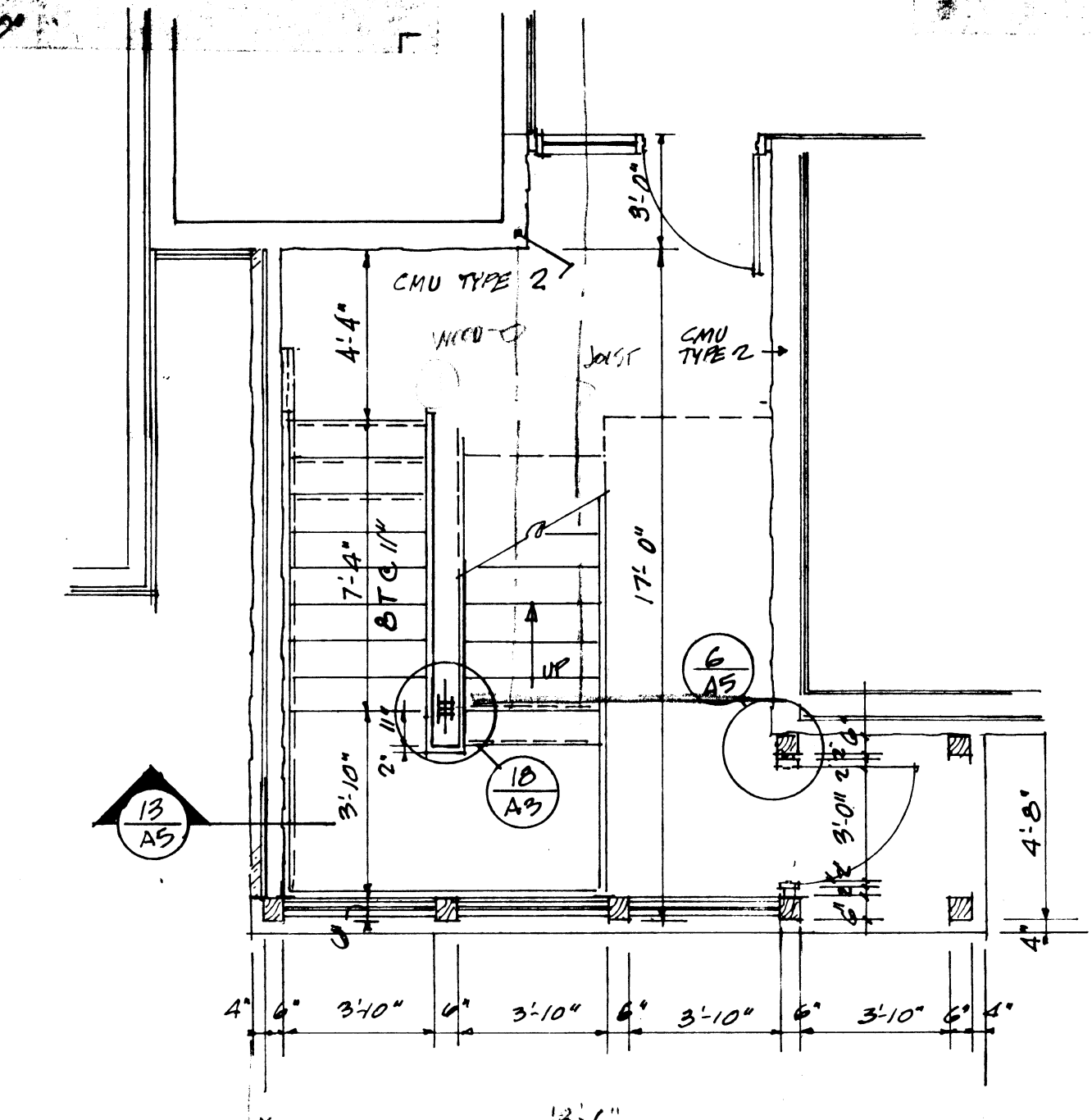

FIRST FLOOR STAIR PLAN 5
SCALE 1/8" = 1'-0"

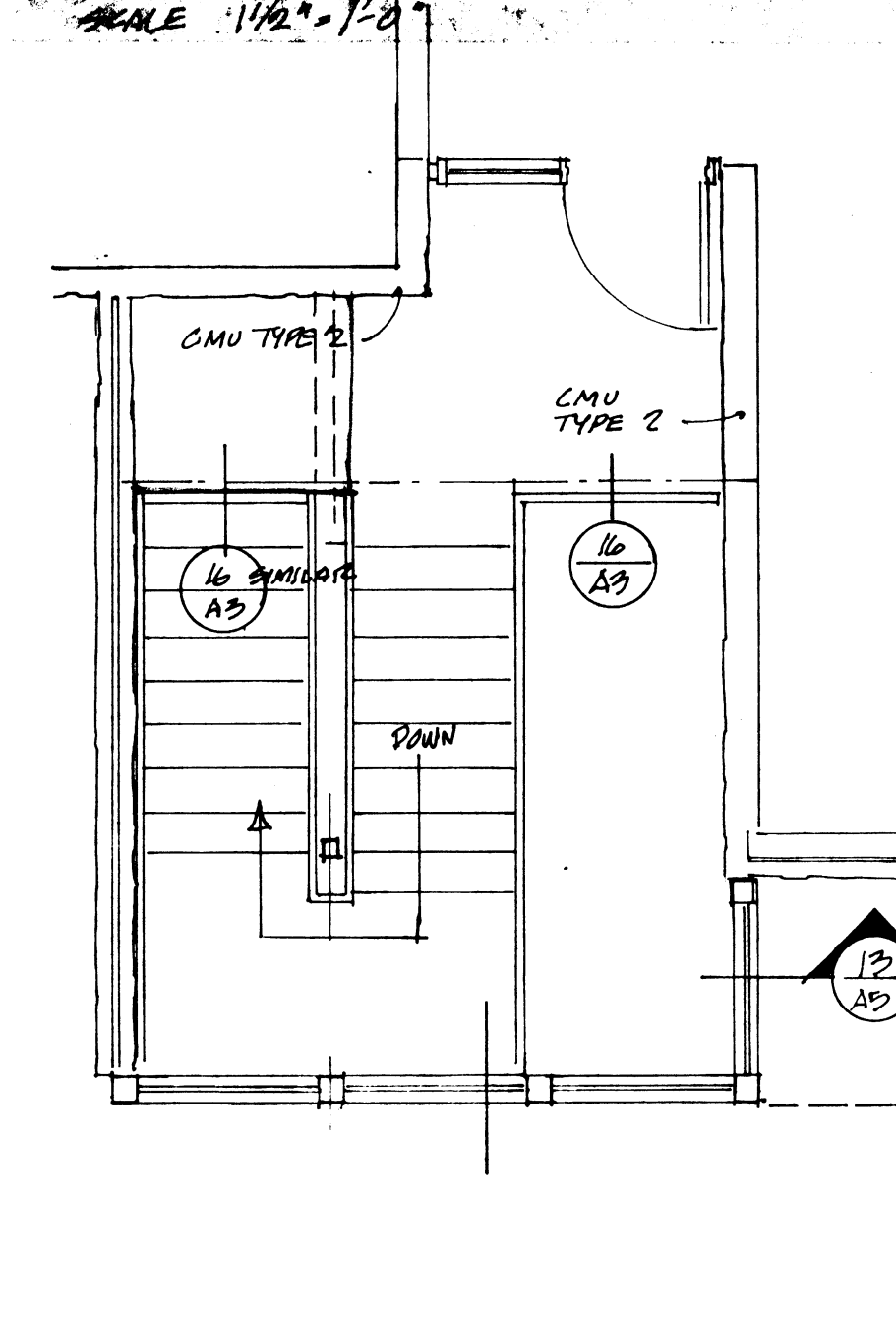

MEZZ STAIR PLAN 1
SCALE 1/8" = 1'-0"

REFERENCE NOTES

1. IN THE MEZZANINE (SECOND) FLOOR SHELL, NO FURRING, INSULATION OR WALL FINISHES ARE TO BE APPLIED UNDER THIS CONTRACT.
2. DROPPED SOFFITS TO ACCOMMODATE MECHANICAL WORK SHALL BE CONSTRUCTED AT THE NORTH AND SOUTH ENDS OF MULTI-PURPOSE 108. USE ACOUSTICAL TILE AND SUSPENSION SYSTEM TO CONSTRUCT SOFFITS.

EQUIPMENT MAINTENANCE FACILITY
BRADLEY PARK, PEORIA, ILLINOIS
for PLEASURE DRIVEWAY AND PARK DISTRICT OF PEORIA

Checked By: _____
Drawn By: _____
Revised: _____
Sheet No. **A5**

Job No. 187055
Date 6-24-88