

## ADDENDUM #1

Peoria Park District  
Planning, Design and Construction Department  
1314 N. Park Road  
Peoria, IL 61604  
Telephone: (309) 686-3386

ADDENDUM NO. ONE  
PROJECT TITLE: Site Improvements  
Logan Park

ISSUANCE DATE: 7/06/2023

The proposed Contract Documents for this Work are modified as follows:

I. **GENERAL INFORMATION:**

CLARIFICATION: The incorrect time for the bid opening was announced at the July 5, 2023 pre-bid meeting. The bid opening is scheduled for Wednesday, July 12, 2023 at 10:00am.

II. **DRAWINGS:**

**Remove** the existing sheet 7 of the Poligon Picnic shelter drawing set and **replace** with attached sheet 7.

III. **PROJECT MANUAL/SPECIFICATIONS.:**

Supplementary Instructions to Bidders, number 12, Construction Timeline and Liquidated Damages Clause, number 2, remove “Sidewalk bordering playground must be complete no later than August 22, 2023” and **add** “Earthwork for playground and sidewalk bordering playground must be complete no later than August 22, 2023.



Sample Agreement Between Owner and Contractor, V. Dates of Communication and Completion of the Work, B. **remove** “Sidewalk bordering playground must be complete no later than August 22, 2023” and **add** “Earthwork for playground and sidewalk bordering playground must be complete no later than August 22, 2023.

Replace the “Section 3 Reporting” forms in Attachment D with the attached forms.

Replace the “Davis-Bacon Wage Rates” from Attachment D with the attached sheets.

IV. **INVITATION TO BID:**

**PART DESCRIPTIONS:**

-  #12-14x3/4" SELF DRILLING SCREW.
-  #12-24x1 1/4" SELF DRILLING SCREW.
-  1/8" POP RIVET.

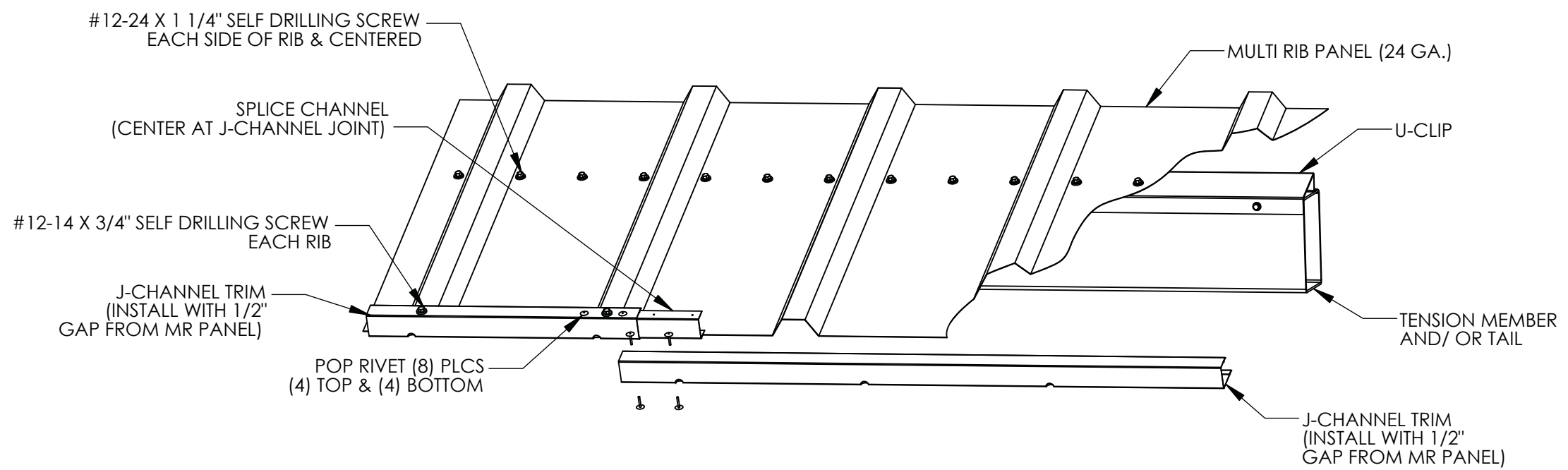

2023A

EAVE DETAIL

MR-100

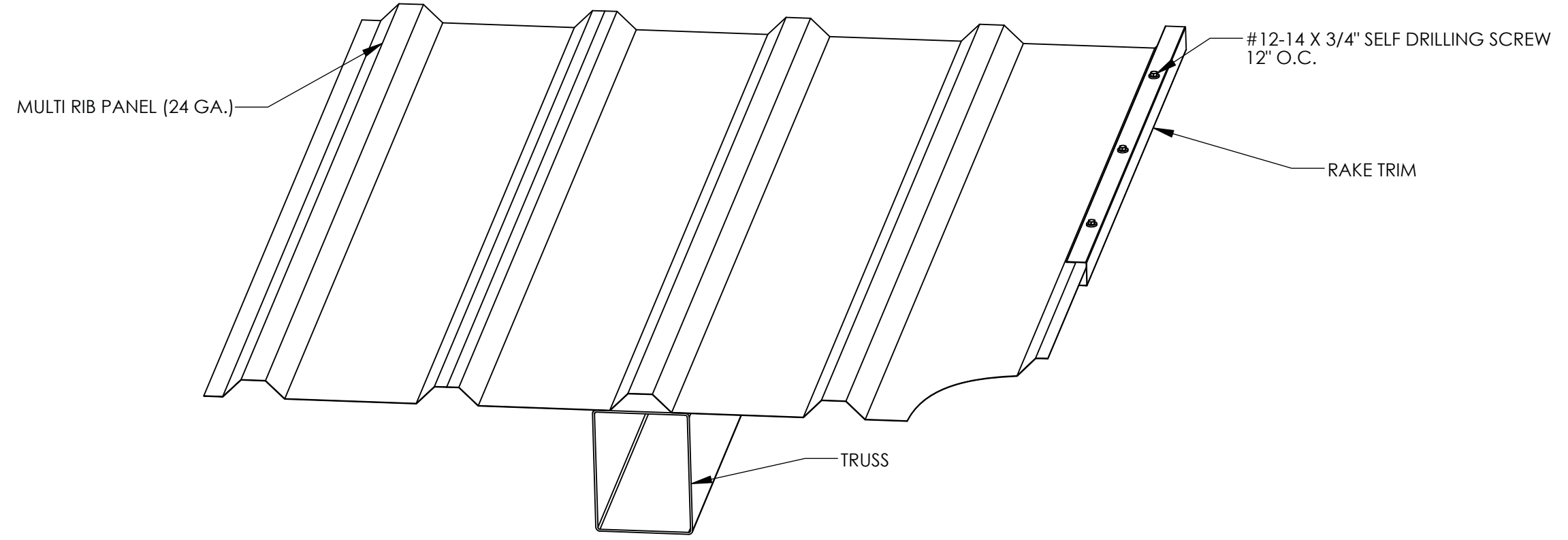

2022A

RAKE DETAIL

MR-400

PRINT DATE:	7/6/2023	SCALE:	NTS
DRAWN BY:	Michael Wood	REV LEVEL:	A
CREATION DATE:	4/4/2016	ORDER NO:	76135
		CAD MODEL:	~P16976

PROJECT:	Logan Park
PROJECT LOCATION:	Peoria, IL
DRAWING:	ROOF CONNECTION DETAILS

SHEET

**7**

IF THESE DRAWINGS ARE SEALED, THE SEAL APPLIES ONLY TO BUILDING COMPONENTS (AND FOUNDATION DESIGN IF APPLICABLE) DETAILED WITHIN THESE DRAWINGS.



**CITY OF PEORIA  
COMMUNITY DEVELOPMENT DEPARTMENT  
GRANTS DIVISION  
SECTION 3 REPORTING**

U.S. DEPARTMENT OF HOUSING AND URBAN DEVELOPMENT (HUD) REGULATIONS REQUIRE JURISDICTIONS TO COLLECT SECTION 3 INFORMATION TO THE BEST OF ITS ABILITY. THE PURPOSE OF SECTION 3 IS TO ENSURE THAT EMPLOYMENT AND ECONOMIC OPPORTUNITIES GENERATED BY HUD FINANCIAL ASSISTANCE IS DIRECTED, WHEREVER FEASIBLE, TO LOWER INCOME PERSONS.

**CONTRACTOR INFORMATION AND CERTIFICATION**

<b>1. Contractor Name and Address</b>	<b>2. Project No.</b>	<b>3. Dollar Amount of Project</b>
	<b>4. Primary Contact</b>	<b>5. Phone No.</b>
	<b>6. E-mail</b>	<b>7. Date Report Submitted</b>
<b>8. Reporting Period</b>		
<b>9. Project Site/Location</b>		

**Type of Business**

- Corporation
- Partnership
- Sole Proprietorship
- Joint Venture

**Please check the following if applicable:**

- Is your company woman owned?
- Is your company minority owned?

If so, please indicate minority group: \_\_\_\_\_

**Section 3 Business Concern Qualifications**

Please check the box for the items that apply to your business.

- Is your business at least 51% owned and controlled by low- or very low- income residents?
- Are at least 75% of the labor hours performed by your business over the last 3 months done so by Section 3 Workers?
- Is at least 51% of your business owned and controlled by current public housing residents or residents who currently live in Section 8-assisted housing?

I certify that the above-named Business is my own and the information provided is true to the best of my knowledge and belief. I understand the information provided may be subject to verification by local and federal agencies, and that there is a penalty for falsifying information.

\_\_\_\_\_  
Signature

\_\_\_\_\_  
Date



**WORK FORCE BREAKDOWN**

<b>Employment and Training</b>					
<b>Job Category</b>	<b>Total Estimated Hours needed for Project</b>	<b>Number of Hours Allocated to Permanent Employees</b>	<b>Number of Hours Allocated to Section 3 Residents</b>	<b>Number of Vacant Positions</b>	<b>Number of Vacant Positions to be filled with Section 3 Residents</b>
Professionals					
Technicians					
Office/Clerical					
<b>Construction Trades Used:</b>					
Plumbing					
HVAC/Mechanical					
Electrical					
Roofing					
General					
Other (List Below):					
<b>Totals:</b>					

**Note: For housing and community development financial assistance projects, the benchmark for Section 3 workers is set at 25% or more of the total number of labor hours worked by all workers on a Section 3 project. The benchmark for Targeted Section 3 workers is set at 5% or more of the total number of labor hours worked by all workers on a Section 3 project. This means that the 5% is included as part of the 25%.**



**INCOME CERTIFICATION FOR SECTION 3 RESIDENTS**

Please have all Section 3 employees complete this form, if applicable.

Employee Name:		
Job Title:		
Select One:	<input type="checkbox"/> Part-Time	<input type="checkbox"/> Full-Time
Hours/Week		
Employee Address		
Employee Phone Number		

Please check the box next to the number of people in your household on the table below:

Number of People in Household:	<input type="checkbox"/> 1	<input type="checkbox"/> 2	<input type="checkbox"/> 3	<input type="checkbox"/> 4	<input type="checkbox"/> 5	<input type="checkbox"/> 6	<input type="checkbox"/> 7	<input type="checkbox"/> 8
Total Household Income:	\$50,600	\$57,800	\$65,050	\$72,250	\$78,050	\$83,850	\$89,600	\$95,400

In the past year, was your **total household income** above or below the amount underneath the number you checked?  Above  Below

Were you offered health insurance at this business (even if you did not accept it)?  Yes  No

Do you live in public housing?  Yes  No

Please select your race, checking all that apply:

- White       Asian       Native Hawaiian/Other Pacific Islander  
 Black/African American       American Indian/Alaskan Native       Other: \_\_\_\_\_

Are you Hispanic/Latino?  Yes  No

*By signing below, I verify that the information provided on this form is correct to the best of my knowledge. I understand that this information is subject to review by the City of Peoria and the U.S. Department of Housing and Urban Development, and that I may have to provide income documentation if requested. **Please note:** Because these are public funds, all information submitted in this application is subject to publication and/or disclosure under the Freedom of Information Act.*

\_\_\_\_\_  
 Employee Signature  
 419 Fulton Street, Room 307, Peoria, IL 61602-1217  
**Phone** 309.494.8600 **Fax** 309.494.8680

\_\_\_\_\_  
 Date



***JOB OPPORTUNITY POSTING***

**BUSINESS INFORMATION**

<b>Company Name</b>	
<b>Industry</b>	
<b>Size</b>	
<b>Address</b>	
<b>Zip Code</b>	
<b>City</b>	
<b>State</b>	

**HUMAN RESOURCE CONTACT DETAILS**

<b>Name</b>	
<b>Phone Number</b>	
<b>E-mail</b>	

**JOB OPPORTUNITY WEBLINK**

--

**SUMMARY:**

**MINIMUM REQUIREMENTS:**

**IMPORTANT SKILLS:**

**APPLY BY:  
POSITION OPEN UNTIL:**

Superseded General Decision Number: IL20220003

State: Illinois

Construction Types: Building and Residential

Counties: Peoria and Tazewell Counties in Illinois.

BUILDING & RESIDENTIAL CONSTRUCTION PROJECTS (including single family homes and garden apartments up to and including 4 stories)

Note: Contracts subject to the Davis-Bacon Act are generally required to pay at least the applicable minimum wage rate required under Executive Order 14026 or Executive Order 13658. Please note that these Executive Orders apply to covered contracts entered into by the federal government that are subject to the Davis-Bacon Act itself, but do not apply to contracts subject only to the Davis-Bacon Related Acts, including those set forth at 29 CFR 5.1(a)(2)-(60).

If the contract is entered into on or after January 30, 2022, or the contract is renewed or extended (e.g., an option is exercised) on or after January 30, 2022:	. Executive Order 14026 generally applies to the contract. . The contractor must pay all covered workers at least \$16.20 per hour (or the applicable wage rate listed on this wage determination, if it is higher) for all hours spent performing on the contract in 2023.
If the contract was awarded on or between January 1, 2015 and January 29, 2022, and the contract is not renewed or extended on or after January 30, 2022:	. Executive Order 13658 generally applies to the contract. . The contractor must pay all covered workers at least \$12.15 per hour (or the applicable wage rate listed on this wage determination, if it is higher) for all hours spent performing on that contract in 2023.

The applicable Executive Order minimum wage rate will be adjusted annually. If this contract is covered by one of the Executive Orders and a classification considered necessary for performance of work on the contract does not appear on this wage determination, the contractor must still submit a conformance request.

Additional information on contractor requirements and worker protections under the Executive Orders is available at <http://www.dol.gov/whd/govcontracts>.

1	01/13/2023
2	01/27/2023
3	02/24/2023
4	04/07/2023
5	05/05/2023
6	05/12/2023
7	05/26/2023
8	06/02/2023
9	06/23/2023

BOIL0060-002 01/01/2021

	Rates	Fringes
BOILERMAKER.....	\$ 41.00	30.04

BRIL0006-006 06/01/2021

	Rates	Fringes
BRICKLAYER.....	\$ 36.83	24.47

BRIL0006-013 06/01/2021

PEORIA AND TAZEWELL COUNTIES

	Rates	Fringes
Marble & Tile Setter and Terrazzo Worker.....	\$ 37.60	24.48

BRIL0006-014 06/01/2021

PEORIA AND TAZEWELL COUNTIES

	Rates	Fringes
Base Machine Men (Base Machine Operator).....	\$ 34.16	24.46

CARP0237-011 05/15/2020

PEORIA and TAZEWELL COUNTIES

	Rates	Fringes
CARPENTER (Building)		
Journeyman.....	\$ 33.58	29.10
Piledriverman.....	\$ 34.58	29.10
CARPENTER (Residential).....	\$ 30.22	29.10

CARP1051-002 05/15/2020

	Rates	Fringes
MILLWRIGHT.....	\$ 33.06	29.97

ELEC0034-004 01/01/2023

	Rates	Fringes
ELECTRICIAN (Building).....	\$ 39.50	24.24
ELECTRICIAN (Residential).....	\$ 24.58	15.99

ELEV0055-002 01/01/2023



	Rates	Fringes
ELEVATOR MECHANIC.....	\$ 53.26	37.335+a+b

FOOTNOTES:

A. Employer contributes 8% of regular basic hourly rate as vacation pay credit for employees with more than 5 years of service, and 6% for under 5 years of service.

B. Paid Holidays: New Year's Day; Memorial Day; Independence Day; Labor Day; Thanksgiving Day; Day after Thanksgiving; Veterans' Day & Christmas Day

-----  
 ENGI0649-003 04/01/2023

	Rates	Fringes
OPERATOR: Power Equipment		
Group 1.....	\$ 45.12	39.35
Group 2.....	\$ 41.70	39.35
Group 3.....	\$ 36.08	39.35

POWER EQUIPMENT OPERATOR CLASSIFICATIONS

GROUP 1: Overhead Cranes; Gradall; All Rough Terrain Hydraulic Cranes (Cherry Pickers) 91,000 lbs gross vehicle weight and over require an oiler; Mechanics; Central Concrete Mixing Plant Operator; Road Pavers (Single Drum, Dual Drum, Tri-batchers); Blacktop Plant Operators and Plant Engineers; 3-Drum Hoist; Derricks; Hydro Cranes (non-lattice boom truck cranes having three (3) axles or less shall not require an oiler, a dolly shall count as an axle); Shovels; Skimmer Scoops; Koehring Scooper; Draglines; Backhoe; Derrick Boats; 360" Swing Excavators; Locomotive Cranes; Dredge (all types); Guard Rail Machines ( machines that cannot be moved forward from the post pounder seat requires an oiler); Motor Patrol; Power Blades-Dumore-Elevating and Similar Types; Tower Cranes (Crawler-Mobile) and Stationary; Crane-Type Back-Filler; Drott Yumbo and Similar Types Considered as Cranes; Caisson Rigs; Dozer; Tournadozer; Work Boats; Ross Carrier; Tunnel Boring Machine (shall require an oiler); Carts/haul units for a boring machine; Helicopter; Tournapulls - All and Similar Types; Scoops (all sizes); Pushcats; Endloaders (all types); Asphalt Surfacing Machine; Slip Form Paver; Rock Crusher; Heavy Equipment Greaser; CMI, CMI Belt Placer, Auto Grade & 3 Track and Similar Types; Side Booms; Multiple Unit Earth Movers: .75 cents per hr., for each Scoop over one (1); Creter Crane; Trench Machine; Pumpcrete-Belt Crete- Squeeze Cretes-Screw-Type Pumps and Gypsum, Bulker & Pump- Operator will clean; Formless Finishing Machine; Flaherty Spreader or Similar Types; Screee Man on Laydown Machine; Wheel Tractors (Industrial or Farm-Type w/Dozer-Hoe-Endloader or other attachments); FWD & Similar Types; Vermeer Concrete Saw; Self Propelled Concrete Saw; Material Crusher; Screening Plants; Laser Screed; Span Saw; Lull & Similar Types; Off Road Trucks, Articulating End Dump Vehicles & Similar Types; Concrete & All Recycling Machines

GROUP 2 - Dinkeys; Power Launches; PH One-Pass Soil-Cement Machine (and similar types); Pugmill with Pump;

Backfillers; Euclid Loader; Forklifts; Jeeps w/Ditching Machine or other attachments; Tunneler; Automatic Cement and Gravel Batching Plants; Mobile Drills (Soil Testing) and Similar Types; Gurries and Similar Types; 1 and 2 Drum Hoists (Buck Hoists and similar types); Chicago Boom; Horizontal Boring Machine & Pipe Jacking Machine; Hydro Boom; Dewatering System; Straw Blower; Hydro Seeder; Assistant Heavy Equipment Greaser on Spread; Tractors (Track- Type) without Power Unit Pulling Rollers; Rollers on Asphalt - Brick or Macadam; Concrete Breakers; Concrete Spreaders; Mule Pulling Rollers; Cement Stripper; Cement Finishing Machines & CMI Texture & Reel Curing Machines; Cement Finishing Machine; Barber Green or similar loaders; Vibro Tamper (all similar types) Self- Propelled; Winch or Boom Truck; Mechanical Bull Floats; Mixers over 3 Bags; Tractor Pulling Power Blade or Elevating Grader; Porter Rex Rail; Clary Screed; Truck-Type Oilers with CDL; Fireman; Spray Machine on Paving; Curb Machines; Truck Crane Oilers with CDL; Oil Distributor; Truck-Mounted Saws; All Elevator, permanently installed used for hoisting or lowering building material; Construction Elevator temporarily installed

GROUP 3 - Air Compressor; Herman Nelson Heater, Dravo, Warner, Silent Glo, and similar types; Water Pump(s); Light Plants; Generators; Welding Machines; Power Subgrader; Straight Tractor; Trac Air without attachments; Roller: five (5) ton and under on earth or gravel; Form Grader; Crawler Crane, Skid Rig Oilers & Oilers with CDL; Conveyor (1) or (2); Mixer (3) Bag and under(Standard Capacity with skip); Bulk Cement Plant; Oiler on Central Concrete Mixing Plant; Stud Welder

-----  
 IRON0112-003 05/01/2023

PEORIA and TAZEWELL COUNTIES

	Rates	Fringes
IRONWORKER.....	\$ 35.81	32.54

-----  
 LABO0165-001 05/01/2023

PEORIA and TAZEWELL (Northwest) COUNTIES

	Rates	Fringes
LABORER		
Group 1.....	\$ 30.50	31.59
Group 2.....	\$ 30.90	31.59
Group 3.....	\$ 31.50	31.59

LABORER CLASSIFICATIONS

GROUP 1 - General Laborer - Air Tamper; Bricklayer Tender; Hazardous Waste Worker (Levels C & D); Carpenter Tender; Cement Mason and Sack Shakers; Cement Mason Tender; Chain Saw; Compact Rammer Type; Concrete Form Dismantler; Concrete Form Dismantler in Composite Crew/Carpenter; Concrete Saw; Curing Concrete; Drill Operator, Jackhammer (Open); High Pressure Hose; Paving Breaker; Plaster Tender; Power Wheelbarrows or Buggies; Setting up and using Laser Beam Equipment; Signaling and Spotting of Buckets on Rig or Rig Men; Stone, Tile and Derrick Men; Tool Crib Men;

Watchmen; Window Washers; Wrecking, Dismantling old buildings; Wall Men and Housemover

GROUP 2 - Skilled Laborer - Concrete Specialist; Cutting and Acetylene Torch; Gunnite Nozzlemen; Gunnite Pump Men and Pots; Kettlemen and Carriers of men handling hot stuff; Sandblast Nozzle Men; Sandblast Nozzle Men and Pots; Setting up and using Concrete Burning Bars; Wood Block Setters; Underpinning and Shoring of existing buildings; Unloading and Handling of all Material Coated with Creosote

GROUP 3 - Asbestos Abatement Worker (removal/encapsulation); Lead Base Paint Abatement Worker (removal/encapsulation); Hazardous Waste Worker (Level A & B)

-----  
\* LAB00231-001 05/01/2023

TAZEWELL COUNTY (Southeast)

	Rates	Fringes
LABORER		
Building.....	\$ 32.00	29.27
Residential.....	\$ 23.20	26.05

-----  
PAIN0157-001 06/01/2022

FULTON, MARSHALL, MASON, PEORIA, SCHUYLER, TAZEWELL AND WOODFORD COUNTIES

	Rates	Fringes
PAINTER		
Brush, Spray, Pressure Roller, Sandblasting, Bridges, & New Structural Steel Work.....	\$ 38.94	26.06

-----  
PAIN0157-010 05/01/2023

PEORIA AND TAZWELL COUNTIES

	Rates	Fringes
GLAZIER.....	\$ 38.59	26.78

-----  
PLAS0018-014 05/01/2021

	Rates	Fringes
CEMENT MASON/CONCRETE FINISHER...	\$ 31.48	30.33
PLASTERER.....	\$ 31.00	30.07

-----  
PLUM0063-001 05/01/2023

	Rates	Fringes
PLUMBER.....	\$ 38.25	27.93

-----  
PLUM0353-001 05/01/2023

	Rates	Fringes
--	-------	---------

PIPEFITTER.....\$ 40.10                    27.19  
 -----

ROOF0069-001 06/01/2023

	Rates	Fringes
ROOFER.....	\$ 34.00	24.15

-----

SHEE0001-002 05/01/2023

	Rates	Fringes
Sheet Metal Worker		
Building.....	\$ 37.82	32.43
Residential.....	\$ 27.69	32.43

-----

TEAM0627-001 05/01/2022

	Rates	Fringes
TRUCK DRIVER		
GROUP 1.....	\$ 40.91	22.10
GROUP 2.....	\$ 41.50	22.10
GROUP 3.....	\$ 41.77	22.10
GROUP 4.....	\$ 42.16	22.10
GROUP 5.....	\$ 43.26	22.10

CLASSIFICATIONS:

GROUP 1: Drivers on 2 axles hauling less than 9 tons; air compressor & welding machines and brooms, including those pulled by separate units; Truck Driver Helper, warehouse employees; Mechanic Helpers; greasers and tiremen; pick-up trucks when hauling material, tools, or workers to and from and on the job site; and forklifts up to 6,000 lb capacity.

GROUP 2: 2 or 3 axles hauling more than 9 tons but hauling less than 16 tons; A-frame winch trucks; hydrolift trucks; Vactor Trucks or similar equipment when used for transportation purposes; Forklift over 6,000 lb.capacity; winch trucks; and four axle combination units.

GROUP 3: 2, 3 or 4 Axles hauling 16 tons or more; 5-Axles or more combination units; drivers on water pulls; articulated dump trucks; mechanics and working forepersons.

GROUP 4: Low Boy and Oil Distributors.

GROUP 5: Drivers who require special protective clothing while employed on hazardous waste work.

-----

WELDERS - Receive rate prescribed for craft performing operation to which welding is incidental.

=====

Note: Executive Order (EO) 13706, Establishing Paid Sick Leave for Federal Contractors applies to all contracts subject to the Davis-Bacon Act for which the contract is awarded (and any solicitation was issued) on or after January 1, 2017. If this contract is covered by the EO, the contractor must provide employees with 1 hour of paid sick leave for every 30 hours they work, up to 56 hours of paid sick leave each year.

Employees must be permitted to use paid sick leave for their own illness, injury or other health-related needs, including preventive care; to assist a family member (or person who is like family to the employee) who is ill, injured, or has other health-related needs, including preventive care; or for reasons resulting from, or to assist a family member (or person who is like family to the employee) who is a victim of, domestic violence, sexual assault, or stalking. Additional information on contractor requirements and worker protections under the EO is available at <https://www.dol.gov/agencies/whd/government-contracts>.

Unlisted classifications needed for work not included within the scope of the classifications listed may be added after award only as provided in the labor standards contract clauses (29CFR 5.5 (a) (1) (ii)).

-----

The body of each wage determination lists the classification and wage rates that have been found to be prevailing for the cited type(s) of construction in the area covered by the wage determination. The classifications are listed in alphabetical order of ""identifiers"" that indicate whether the particular rate is a union rate (current union negotiated rate for local), a survey rate (weighted average rate) or a union average rate (weighted union average rate).

#### Union Rate Identifiers

A four letter classification abbreviation identifier enclosed in dotted lines beginning with characters other than ""SU"" or ""UAVG"" denotes that the union classification and rate were prevailing for that classification in the survey. Example: PLUM0198-005 07/01/2014. PLUM is an abbreviation identifier of the union which prevailed in the survey for this classification, which in this example would be Plumbers. 0198 indicates the local union number or district council number where applicable, i.e., Plumbers Local 0198. The next number, 005 in the example, is an internal number used in processing the wage determination. 07/01/2014 is the effective date of the most current negotiated rate, which in this example is July 1, 2014.

Union prevailing wage rates are updated to reflect all rate changes in the collective bargaining agreement (CBA) governing this classification and rate.

#### Survey Rate Identifiers

Classifications listed under the ""SU"" identifier indicate that no one rate prevailed for this classification in the survey and the published rate is derived by computing a weighted average rate based on all the rates reported in the survey for that classification. As this weighted average rate includes all rates reported in the survey, it may include both union and non-union rates. Example: SULA2012-007 5/13/2014. SU indicates the rates are survey rates based on a weighted average calculation of rates and are not majority rates. LA indicates the State of Louisiana. 2012 is the year of survey on which these classifications and rates are based. The next number, 007 in the example, is an internal number used in producing the wage determination. 5/13/2014 indicates the survey completion

date for the classifications and rates under that identifier.

Survey wage rates are not updated and remain in effect until a new survey is conducted.

#### Union Average Rate Identifiers

Classification(s) listed under the UAVG identifier indicate that no single majority rate prevailed for those classifications; however, 100% of the data reported for the classifications was union data. EXAMPLE: UAVG-OH-0010 08/29/2014. UAVG indicates that the rate is a weighted union average rate. OH indicates the state. The next number, 0010 in the example, is an internal number used in producing the wage determination. 08/29/2014 indicates the survey completion date for the classifications and rates under that identifier.

A UAVG rate will be updated once a year, usually in January of each year, to reflect a weighted average of the current negotiated/CBA rate of the union locals from which the rate is based.

---

#### WAGE DETERMINATION APPEALS PROCESS

1.) Has there been an initial decision in the matter? This can be:

- \* an existing published wage determination
- \* a survey underlying a wage determination
- \* a Wage and Hour Division letter setting forth a position on a wage determination matter
- \* a conformance (additional classification and rate) ruling

On survey related matters, initial contact, including requests for summaries of surveys, should be with the Wage and Hour National Office because National Office has responsibility for the Davis-Bacon survey program. If the response from this initial contact is not satisfactory, then the process described in 2.) and 3.) should be followed.

With regard to any other matter not yet ripe for the formal process described here, initial contact should be with the Branch of Construction Wage Determinations. Write to:

Branch of Construction Wage Determinations  
Wage and Hour Division  
U.S. Department of Labor  
200 Constitution Avenue, N.W.  
Washington, DC 20210

2.) If the answer to the question in 1.) is yes, then an interested party (those affected by the action) can request review and reconsideration from the Wage and Hour Administrator (See 29 CFR Part 1.8 and 29 CFR Part 7). Write to:

Wage and Hour Administrator  
U.S. Department of Labor  
200 Constitution Avenue, N.W.  
Washington, DC 20210

The request should be accompanied by a full statement of the

interested party's position and by any information (wage payment data, project description, area practice material, etc.) that the requestor considers relevant to the issue.

3.) If the decision of the Administrator is not favorable, an interested party may appeal directly to the Administrative Review Board (formerly the Wage Appeals Board). Write to:

Administrative Review Board  
U.S. Department of Labor  
200 Constitution Avenue, N.W.  
Washington, DC 20210

4.) All decisions by the Administrative Review Board are final.

=====

END OF GENERAL DECISIO"